

Teignmouth Management Plan

Document no: 1

Revision: 2

Teignbridge District Council

Teignmouth Beach Management Plan

26 November 2025



Teignmouth and Shaldon Beach Management Plan

Client name: Teignbridge District Council
Project name: Teignmouth Beach Management Plan
Client reference: **Project no:** B2471100
Document no: 1 **Project manager:** Emma Allan
Revision: 2 **Prepared by:** Emma Allan
Date: 26 November 2025 **File name:** Teignmouth and Shaldon Beach Management Plan_v5_FINAL

Document status:

Document history and status

Revision	Date	Description	Author	Checked	Reviewed	Approved
1	18.09.25	Draft for Client review	EA	LOT	LOT	EA
2	12-26.11.25	Final	EA	JE	LOT	EA

Distribution of copies

Revision	Issue approved	Date issued	Issued to	Comments
1	Draft for Client Review	25.09.25	TDC	For Client review and comment.
2	Final for Client	26.11.25	TDC	Final addressing Client comments.

Jacobs U.K. Limited

Aperture @ Pynes Hill, Rydon Lane
Exeter, EX2 5AZ
United Kingdom

T +44 (0)139 226 9800
www.jacobs.com

© Copyright 2025 Jacobs U.K. Limited. All rights reserved. The content and information contained in this document are the property of the Jacobs group of companies ("Jacobs Group"). Publication, distribution, or reproduction of this document in whole or in part without the written permission of Jacobs Group constitutes an infringement of copyright. Jacobs, the Jacobs logo, and all other Jacobs Group trademarks are the property of Jacobs Group.

NOTICE: This document has been prepared exclusively for the use and benefit of Jacobs Group client. Jacobs Group accepts no liability or responsibility for any use or reliance upon this document by any third party.

Executive Summary

This Beach Management Plan (BMP) for Teignmouth and Shaldon has been prepared for Teignbridge District Council and their partner, the Environment Agency. The BMP boundary extends from The Ness, Shaldon, the Teign Estuary as far as Shaldon Bridge, and Back Beach/The Point to The Parson and Clerk headland to the North. It excludes Holcombe beach from the eastern extent of Teignmouth seafront beach to Parsons Tunnel. However, as requested by the Client, the future management extent only extended into the estuary as far as Clipper Quay and north as far as East Cliff.

This BMP provides an update to the 2014 study (CH2M, 2014) and takes into account the latest data, and the findings of new studies completed for the current BMP, including new numerical modelling and a new options appraisal, to provide a management regime to manage the risks from flooding and coastal erosion for the next 20-30 years within the context of the long term (100 year) Shoreline Management Policy (SMP) intent for the BMP frontage.

The new studies are presented in four baseline reports, presented as appendices to the BMP, and summarised in relevant sections throughout the BMP.

1. Coastal Processes Baseline.
2. Defences Baseline.
3. Environmental Baseline.
4. Economic Baseline.

Together, the studies have helped to:

- Better understand the coastal processes operating along the BMP frontage and the potential causes for beach lowering at Shaldon, Back Beach and Teignmouth.
- Provide an up-to-date assessment of the condition of the current defences, and better understand the potential flood risk damages in the BMP area.
- Better understand the influence that The Point breakwater has on shoreline change and the implications that this has for flood and coastal management across the BMP frontage.
- Determine what the implications of different management options can have on shoreline dynamics.
- Assess and test the implications of the current dredge and disposal regime, and make recommendations for future change.

Using the findings of the baseline studies, an assessment of option costs, and working closely with the project's stakeholders, an options appraisal has been undertaken to determine a preferred management approach for the BMP frontage.

The preferred management approach for the BMP frontage is identified as: Option 3, Improve 2 - improve SOS, sustain SOP, see table ES.1, 'Preferred option details', below for more detail. This option assumes the wall is raised in year 2028. If a setback wall is preferred to wall raising, then only repairs to the existing would be undertaken in 2028. This option could be adjusted to raise the wall/install a setback wall later, which require a review of the costs used in the options appraisal.

Alongside this, it is recommended that options to beneficially use the material dredged from the estuary channel and the eroding cliffs landward of the railway are undertaken with immediate effect.

The BMP sets out a recommended monitoring and maintenance regime for the BMP frontage for the existing defences, and assuming the implementation of the preferred option. It is recommended that the BMP is updated in the future when and should any change to the current management regime changes. This along

with a series of recommendations for future activities are captured within the BMP Action Plan, presented at the end of the report.

Table ES.1 Preferred option details.

Location	Measure Detail / Implementation (RL = Residual Life and SoP = Standard of Protection)
Teignmouth Open Coast	Raise the height of the seawall to achieve current levels of overtopping in year 100. If existing wall not suitable for raising consider set-back wall or construct new wall.
Teignmouth Open Coast	Repair and maintain the existing toe piles as they reach the end of their RL, replace sheet piles as they fail due to corrosion with same standard of service (i.e. same length / thickness).
Teignmouth Open Coast	Construct new toe protection at the bottom of the existing wall (below the bottom step) along the entire length of the Teignmouth Open Coast seawall removing reliance on beach to reduce risk from scour and undermining.
Teignmouth Open Coast	Construct a new and improved groyne field that will sustain the current SoP to year 100. e.g. by adjusting groyne length/height/spacing.
The Point	Upgrade existing structure along same alignment so that it is as effective in year 100 as it is today (e.g. by raising).
Teignmouth Back Beach	Raise the height of existing flood defences to achieve current levels of overtopping in year 100. Existing flood warning services continue."
Teignmouth Back Beach	Construct new toe protection at the bottom of the existing wall (below the bottom step) along the entire length of the Teignmouth Back Beach seawall removing reliance on beach to prevent undermining. Proposed structure extents designed to provide existing SoP against undermining (provided by the existing beach) in year 100.
Shaldon	Raise the height of the seawall to achieve current levels of overtopping in year 100. If existing wall not suitable for raising, construct new wall.
Shaldon	Construct new toe protection at the bottom of the existing wall removing reliance on beach to prevent undermining. Proposed structure extents designed to provide existing SoP against undermining (provided by the existing beach) in year 100.
Beneficial use dredged material and cliff debris	Beneficially use the material dredged from the estuary channel and place this on the beach adjacent to Teignmouth Pier, as well as the material collected from eroding cliffs landward of the railway are undertaken with immediate effect.

Contents

Executive Summary	i
1. Introduction	1
1.1 Background.....	1
1.2 Aims and objectives.....	2
1.3 New supporting studies	3
1.4 Teignmouth Remedial Works project.....	3
1.5 Stakeholder engagement	4
1.6 BMP structure	4
2. Critical Drivers and Issues	5
2.1 Flood and erosion risk	5
2.2 Coastal processes.....	6
2.2.1 Tides	6
2.2.2 Waves.....	6
2.2.3 Storms	7
2.2.4 Waves and tidal flows	7
2.2.5 Freshwater flows.....	8
2.2.6 Sediment transport	8
2.2.7 Impacts of sea level rise	9
2.3 Dredging and dredge disposal operations.....	10
2.3.1 Capital dredging	10
2.3.2 Maintenance dredging and disposal	10
2.3.3 Dredged material.....	11
2.4 Lowering beach levels	12
2.4.1 Analysis of beach elevation data	12
2.4.2 Potential causes of lowering beach levels.....	15
2.5 Coastal defence condition	16
2.6 Receptors and damages	17
2.7 Considerations for option implementation.....	17
2.7.1 Responsibilities for management of the coastline	17
2.7.2 Funding sources.....	18
2.7.3 Implications on the environment.....	18
2.7.4 Regulations.....	18
2.7.5 Licenses and consents.....	19
2.7.6 Relevant planning documents and local studies.....	20
3. Management and Maintenance Regime	21
3.1 Future management approach	21
3.1.1 Preferred option	21

3.1.2	Beneficial used of dredge material	21
3.1.3	Beneficial use of eroded cliff material	21
3.2	Structure maintenance - immediate.....	23
3.3	Structure maintenance – future.....	23
3.3.1	Existing defences.....	23
3.3.2	Tidal flood defences	23
3.4	Beach maintenance – trigger levels.....	24
3.4.1	Seawall stability trigger levels	24
3.4.2	Seawall Standard of Protection (SoP) trigger levels.....	25
3.5	Flood warning and response procedures.....	26
3.6	Implementation of management activities.....	26
3.6.1	Plant requirements.....	26
3.6.2	Access	27
3.6.3	Public access, amenity and safety	27
3.6.4	Notifying others	27
4.	Monitoring Regime	28
4.1	Structure monitoring	28
4.1.1	Annual visual inspection	28
4.1.2	Detailed inspection.....	28
4.1.3	Post-storm visual inspection	28
4.1.4	Defect monitoring.....	29
4.2	Beach monitoring.....	29
4.2.1	Annual monitoring reporting (using South-West Regional Coastal Monitoring Programme (SWRCMP))	29
4.2.2	Post storm site visits	29
4.2.3	Trigger level monitoring and response	30
4.3	Beach recycling logs	30
4.4	Environmental monitoring	30
5.	Action Plan.....	32
6.	References	37

Appendices

Appendices	38
Appendix A. Coastal Processes Baseline	39
Appendix B. Defences Baseline	40
Appendix C. Environmental Baseline	41
Appendix D. Economics Baseline	42
Appendix E. Issues, Current Management Practices and Actions	43

Appendix F. Options Appraisal Report44

Tables

Table 1.1 BMP scope objective and issues, with signposting to relevant supporting study2

Table 2.1 Significant and recent storms affecting the BMP frontages.....7

Table 2.2 Recent coastal schemes along the BMP frontage..... 16

Table 2.3 Assigned responsibilities for flood and coastal erosion risk management activities 17

Table 3.1 Preferred option for BMP frontage.22

Table 3.2 Immediate action required for existing defences.....23

Table 5.1 Teignmouth BMP action plan..... 33

Figures

Figure 1-1 The study area (red outline) and BMP frontage (purple line)..... 1

Figure 2-1 Flood risk from rivers and the sea in the BMP area (source: <https://www.gov.uk/check-long-term-flood-risk>).....5

Figure 2-2 Erosion risk map for the BMP area (source: <https://www.gov.uk/check-coastal-erosion-management-in-your-area>)5

Figure 2-3 Directional wave roses of significant wave height (left panel) and peak wave period (right panel), measured by the Dawlish waverider buoy at the -14mODN depth contour, between December 2010 and Feb 2024. The red solid and dashed lines indicate the angle of the shoreline and shore normal wave approach (145°), respectively..... 7

Figure 2-4 Demonstration sediment being transported in opposing directions during a flooding-high tide with southerly wave approach. 9

Figure 2-5 Map showing areas of the estuary channel dredged by THC and the dredge disposal location at Sprey Point (reference number PO070) (source: ADBP LLP, 2024). 11

Figure 2-6 LiDAR difference plot showing beach elevation change for the period 2007–2022 along the Teignmouth open coast. Red colour indicates net loss of material and blue colour indicates net gain of material. 13

Figure 2-7 LiDAR difference plot showing beach elevation change for the period 2007–2022 on Teignmouth Back Beach and Shaldon Beach. Red colour indicates net loss of material and blue colour indicates net gain of material. 14

Figure 2-8 Beach profile change at The Point (source: https://swcm-dashboard.org/main_dash/6bSU18-1). 14

Figure 3-1 Seawall stability assessment area division (Binnies, 2024). 25

1. Introduction

1.1 Background

This Beach Management Plan (BMP) for Teignmouth and Shaldon has been prepared for Teignbridge District Council and their partner, the Environment Agency. The study area (BMP boundary) extends from The Ness, Shaldon; the Teign Estuary as far as Shaldon Bridge, and Back Beach/The Point to The Parson and Clerk headland to the North (see Figure 1-1). However, as requested by the Client, the future management extent only extended into the estuary as far as Clipper Quay and north as far as East Cliff, and excludes Holcombe beach from the eastern extent of Teignmouth seafront beach to Parsons Tunnel, as the defence there is owned and managed by Network Rail.

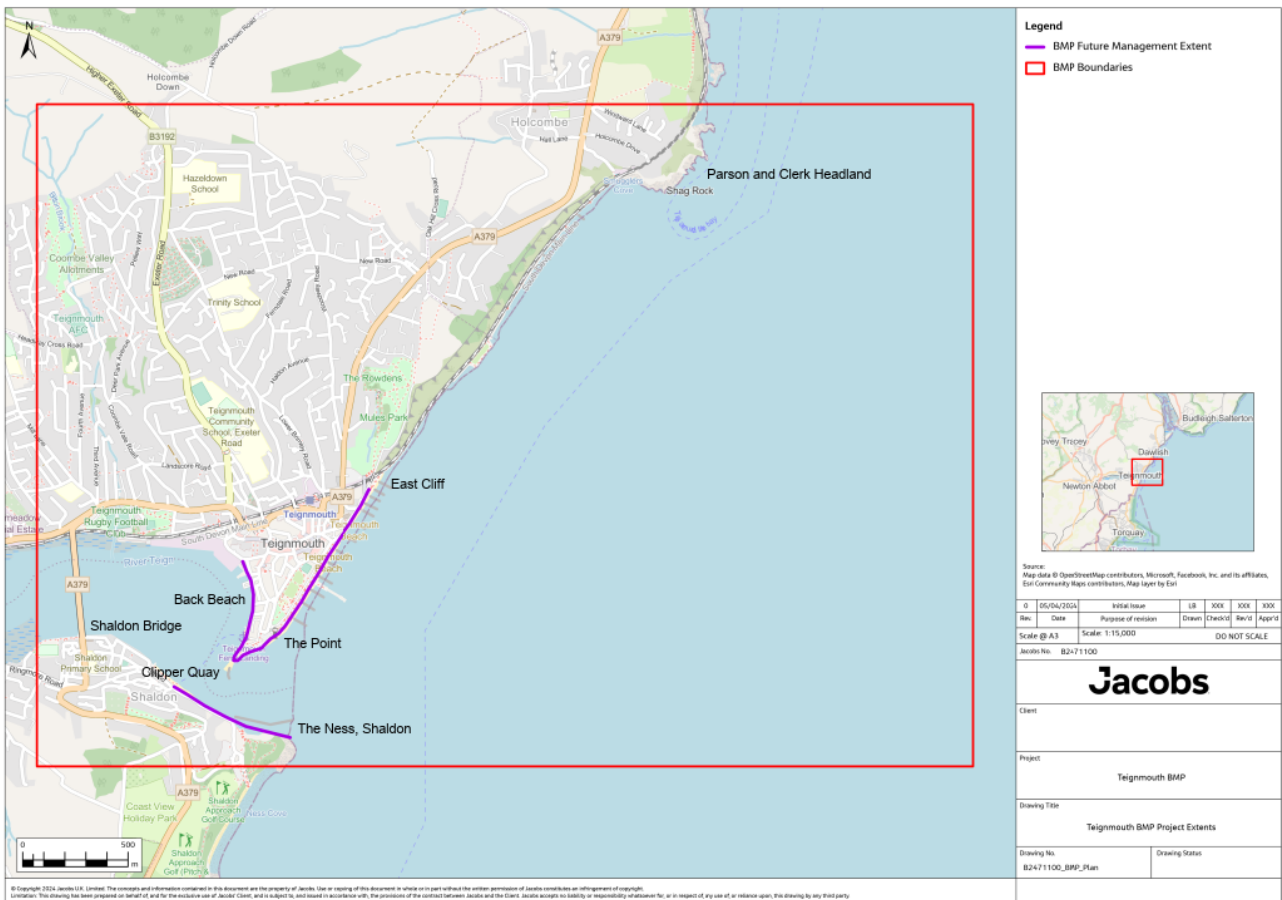

Figure 1-1 The study area (red outline) and BMP frontage (purple line).

The Shaldon and Teignmouth coastline is at risk of both flooding and coastal erosion. To reduce these risks and protect the local assets, various coastal defences have been constructed along the frontage over the years, consisting primarily of flood defences, seawalls and groynes.

This BMP provides an update to the 2014 study (CH2M, 2014) and takes into account latest data, new numerical modelling and a new options appraisal, to provide a management regime to manage the risks from flooding and coastal erosion for the next 20-30 years within the context of the long term (100 year) Shoreline Management Policy (SMP) intent for the BMP frontage, which is Hold the Line for the long term (to 2105), with the exception of The Point, which is Managed Realignment.

1.2 Aims and objectives

The aim of the BMP is to identify management activities to reduce the flood and coastal erosion risk to coastal assets, whilst taking into account any technical constraints and opportunities and present-day funding limitations.

In line with latest CIRIA guidelines (CIRIA,2010), the BMP sets out a preferred management regime for the next 20-30 years, along with a supporting maintenance and monitoring programme for the next five years.

The required outputs, specific objectives and issues to be considered by the current BMP as set out in the project scope are listed in Table 1.1. To help meet those objectives and better understand the related issues, various studies (discussed in more detail in Section 1.3) have been completed during the development of this BMP. Signposting to those relevant pieces of work is also included in Table 1.1.

Table 1.1 BMP scope objective and issues, with signposting to relevant supporting study

BMP Scope Objectives	Related Issues	Relevant Output / Section in BMP
Review the existing coastal processes influencing coastal evolution along the project frontage	<ul style="list-style-type: none"> ▪ Sediment sources, inputs and circulation within the local system – Ness to Holcombe. ▪ Investigating volatile beach levels and observed losses / gains / trends both as a whole frontage and at identified local sections. ▪ Appraising the influence/impact or otherwise of existing navigational dredging undertakings, especially on beach levels and recycling patterns. 	Appendix A (Coastal Processes Baseline)
Identify potential causes for observed beach lowering along Teignmouth seafront, Teignmouth Back Beach and Shaldon beaches		Appendix A (Coastal Processes Baseline)
Produce a model or models to evidence above which can also be used to test future proposals in respect of defences, sediment patterns, maintenance (including dredging/disposal/recharge) operations and climatic change predictions.		Appendix A (Coastal Processes Baseline)
Provide an up-to-date assessment of the Teignmouth seafront defences along the project frontage and for the future	<ul style="list-style-type: none"> ▪ Determining condition and function of groyne field. 	Appendix B (Defences Baseline)
Provide assessment of the economic benefits for future coastal flood and erosion risk management, and identify the key beneficiaries of		Appendix D (Economics Baseline)

such works along the project frontage		
Undertake consultation with key stakeholders at key points in the project		Appendix E (Issues, Current Management Practices and Options)
Identify and appraise a range of options for each part of the project frontage for managing the coastal flood and erosion risks over the next 100 years	<ul style="list-style-type: none"> Identifying and justifying any beach management works required, for example groyne improvements, beach recharge etc. 	Appendix F (Options Appraisal Report) *Note that no coastal change management areas were identified by the BMP.

1.3 New supporting studies

Four baseline studies have been undertaken specifically for the BMP to meet the requirements of the scope, better understand the existing issues and provide supporting information to help develop a preferred management option for the BMP frontage. Each study is included in full as appendices to this main BMP report, and include:

- Coastal Processes Baseline: a literature review, new hydrodynamic (Delft 3D-FM) and beach evolution (ShoreTrans) modelling, new and updated assessment of coastal processes, shoreline interactions and shoreline evolution, including an appraisal of the sediment budget, principal sources and stability of the study area and appraisal of the influence of existing dredging and disposal regime. Further to this, new modelling of The Point breakwater and a selection of management options was also undertaken for the present BMP (presented in Appendix A).
- Defence Baseline: coastal defence assets, condition and performance (presented in Appendix B) – an up to date assessment of the coastal defences was also undertaken at the same time as the BMP and the findings are presented in Binnies (2024).
- Environmental Baseline: environmental setting and features, license and consents requirements and relevant planning documents to which the BMP needs to align/feed into and vice versa (presented in Appendix C).
- Economics Baseline: economic basis (i.e. the economic benefits) for both ongoing and future beach management and flood and coastal erosion risk management activities (presented in Appendix D). *Note, a partnership funding calculator has not been completed for the BMP, however an assessment of the costs to undertake the short-list of measures was completed as part of the options appraisal process.

Unlike the previous study, a synopsis of the baseline studies is not included here. New and key information is drawn on within the next section, Critical Drivers and Issues (see Section 2) and subsequently used within the options appraisal process, as outlined in the Options Appraisal Report (see Appendix F).

1.4 Teignmouth Remedial Works project

At the time of preparing the Teignmouth Beach Management Plan, the Environment Agency are in parallel undertaking the Teignmouth Sea Defence Scheme Remedial Works project, with the objectives to complete necessary repair works to rectify structural stability of the seawall and deliver beach management for the length of the remedial works coastline (further detail is provided in the Options Appraisal Report in Appendix F). Studies completed for the remedial works project were used to support the development of the BMP, however, both projects have been undertaken separately and independently.

1.5 Stakeholder engagement

This BMP was developed in consultation with the projects' Stakeholder Group, who included the following members. Additional input was invited from ABP Teignmouth and Network Rail.

- Teignbridge District Council (TDC).
- The Environment Agency.
- Teignmouth Harbour Commissioners.

At the project outset, a stakeholder plan was prepared, along with a series of non-technical summaries of the four baseline reports, to be used during the consultation process if required. Key stakeholder activities were held throughout the BMP development, to facilitate data collection and the options appraisal process including:

- Stakeholder meeting 1 – presentation on the BMP process and what to expect.
- Stakeholder meeting 2 – presentation on the findings of the baseline studies.
- Long-list confirmation with TDC.
- Short-list confirmation with TDC.
- Stakeholder meeting 3 – presentation of the options appraisal processes and preferred option.

On agreement of the preferred option with the stakeholder group, the final BMP outcomes were disseminated to the Teign Estuary Coastal Partnership Group (TECPG) in November 2025.

1.6 BMP structure

The BMP is set out to include:

- A summary of critical issues and considerations - Section 2.
- Management regime and maintenance programme – Section 3.
- Monitoring programme – Section 4.

2. Critical Drivers and Issues

This section sets out the critical drivers and issues for the Teignmouth BMP frontage, drawing from the issues identified by the project scope, latest studies completed for the BMP and data and information sought via the stakeholder engagement process. The critical drivers and issues have been considered when undertaking the options appraisal process, including derivation of the long and shortlist of options.

2.1 Flood and erosion risk

The Shaldon and Teignmouth coastline has a long history of flooding, overtopping and erosion, exacerbated by increasing risk from rising sea levels. Latest flood and coastal erosion risk mapping produced for the Environment Agency’s National Flood Risk Assessment (NaFRA2) and National Coastal Erosion Risk Mapping (NCERM2) projects show the predicted areas of land that could be impacted by coastal and river flooding, and erosion in the absence of defences (see Figure 2-1 and Figure 2-2 respectively).

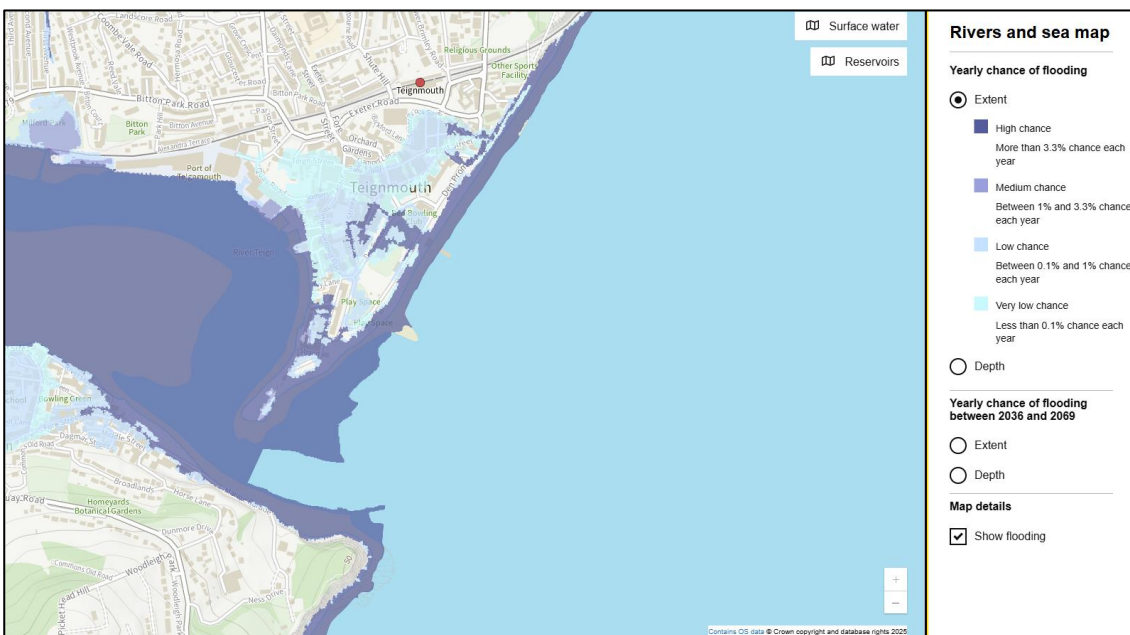

Figure 2-1 Flood risk from rivers and the sea in the BMP area (source: <https://www.gov.uk/check-long-term-flood-risk>).

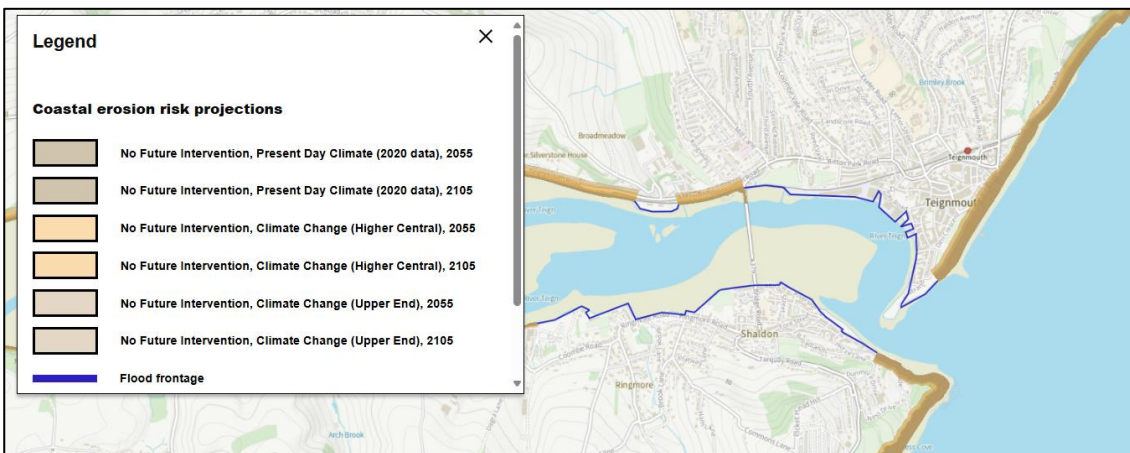

Figure 2-2 Erosion risk map for the BMP area (source: <https://www.gov.uk/check-coastal-erosion-management-in-your-area>).

2.2 Coastal processes

Coastal processes are key drivers to coastal shoreline change and evolution along the BMP frontage and the latest studies completed for the BMP presents new findings that help to better understand the observed changes taking place, including information related to tidal flow patterns, wave climate, direction of sediment, beach elevation change and the impacts of dredging operations in the area. This information has been used to inform the options appraisal and proposed management approach adopted by this current BMP.

This Section provides a synopsis of the key findings from the latest study and should be read in conjunction with the full Coastal Processes Baseline presented in Appendix A, which contains sources to all referenced data and distinguishes between new findings arising from work completed for the current BMP and existing information.

2.2.1 Tides

Spring and neap tidal ranges in the Teign Estuary range from 3.9 m and 1.6m respectively. The estuary flows are ebb-dominated. During spring tides, flood and ebb flow velocities in the estuary mouth can exceed 1.5 m/s and 3 m/s respectively. As tidal flows exit the estuary, they spread out and decrease in velocity. A complex flow circulation occurs over the ebb shoal delta. Further details of the tidal modelling are presented in Section 2.1 of Appendix A.

2.2.2 Waves

Wave climate has a significant influence on sediment transport (see more on this in Section 2.2.6), impacting where sediment is transported to, from and stored. New analysis of the latest wave data for the current BMP shows that there has been a change in wave conditions over the last two decades (December 2010 to February 2024). The results of the latest review and analysis of wave data are summarised below, with more information provided in Section 2.2 of Appendix A.

- A bimodal wave climate, with a dominant wave component from the south-south-east (southerly component), and a secondary component from the east-south-east (easterly component), see Figure 2-3 for wave rose plots.
- A clear seasonality in the wave height, where December, January, and February experience the largest average and maximum wave heights, which usually decline to their minimum values in July.
- A decline in easterly wave conditions, starting in the 1950s, and declining further from the 1990s.
- Relatively constant southerly storm activity over the same period (i.e. since the 1950's).
- For wave data between 2010 and 2024, 2/3rds (67%) of the total wave power came from the south, and only 1/3rd (33%) came from the east.

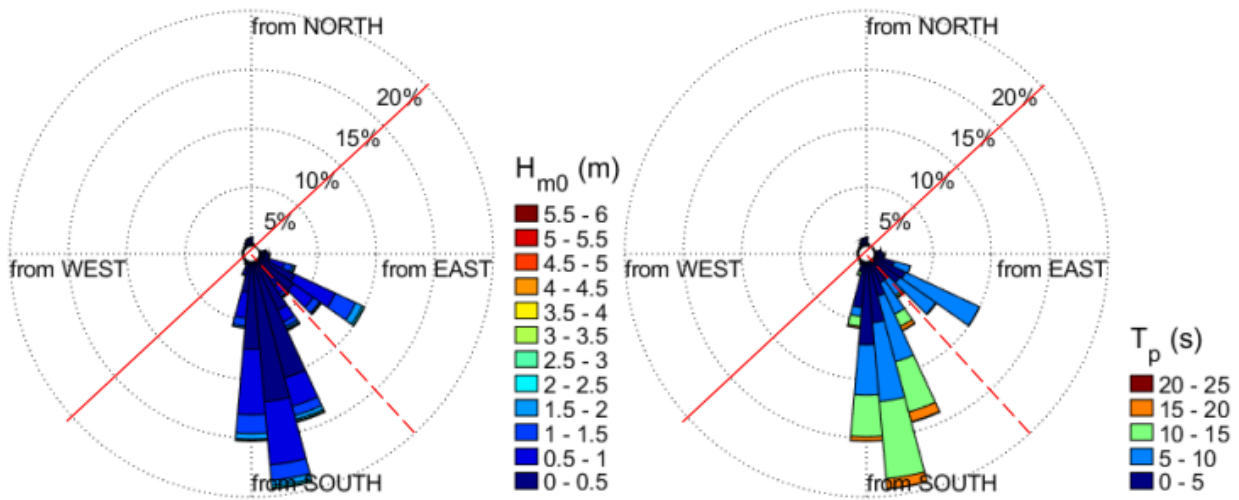

Figure 2-3 Directional wave roses of significant wave height (left panel) and peak wave period (right panel), measured by the Dawlish waverider buoy at the -14mODN depth contour, between December 2010 and Feb 2024. The red solid and dashed lines indicate the angle of the shoreline and shore normal wave approach (145°), respectively.

2.2.3 Storms

Current defences, including several recent schemes at Shaldon and Back Beach help to protect the coastline from flooding and erosion (see the defences baseline in Appendix B for a full review and assessment). However, storms continue to present a significant cause of overtopping with related flooding and erosion of the coastline at Shaldon and Teignmouth, along with overwash of The Point. The most notable storms are listed in Table 2.1.

Table 2.1 Significant and recent storms affecting the BMP frontages.

Storm name	Date of storm
Stormiest since 1969	Winter 2013 / 2014
Storm Emma	March 2018
Storm Babet	October 2023
Storm Ciaran	November 2023
Strom Darragh	December 2024

2.2.4 Waves and tidal flows

Hydrodynamic modelling completed for this BMP shows that under all stages of the tide, easterly storm-threshold waves drive southward wave-driven flows along the shore of approximately 0.7 m/s. Throughout the simulation eddies remain present, changing nearshore flow directions due to the interaction between waves and tidal currents.

Under southerly waves, however, the estuary flows combine with wave driven flows away from the estuary mouth, driving strong northward currents just away from the shore that persist up to Sprey Point, with velocities of 0.5-0.8 m/s.

During flooding and high tide stages, the combined action of wave-driven currents flowing northward and tidally-driven currents flowing southward towards the estuary create a divergence in the flow direction that occurs directly in front of Teignmouth Lighthouse.

2.2.5 Freshwater flows

Freshwater flows acting within the estuary are generally considered to be low in magnitude (compared to estuarine flows) and have negligible influence on the current velocities in the lower estuary (see Section 2.2 of Appendix A for further information).

2.2.6 Sediment transport

The latest modelling completed for the BMP concludes that the BMP frontage is an open sediment cell, with sediment bypassing the Ness Head headland from the south (31,000 m³/year) and moving north past Holcombe headland (24,000 m³/year) through the combined action of waves, tides, and estuary flow. A net sediment gain of 7,000 m³/year is predicted to result across the Teignmouth frontage. Storm wave action and tidally induced flows can significantly increase the volume of sediment exchanged with the wider coastline to the north and south.

The net movement of sediment from Hope's Nose to Holcombe is believed to be from south to north, forced by wave driven transport, with more sediment transported away from the area to the north than is arriving from the south.

A reversal in the net northward littoral transport direction is further supported by the presence of Denn Spit (or The Point), which could not have developed from the northern side of the Teign Estuary without north to south littoral transport occurring.

The location of this reversal was previously thought to occur at Sprey Point, with net littoral drift south to north between Sprey Point and Holcombe and from north to south between Sprey Point and the Teign Estuary. However, latest modelling completed for this BMP does not predict a divergence in net sediment flux divergence at Sprey Point, and as seen from the new assessment of beach profile and elevation change (Section 2.4.1), the shoreline has not experienced chronic erosion, which would be the expected result of such a transport divergence.

Rather, the latest modelling demonstrated that flow divergences (and therefore a net sediment flux divergence) are likely to occur under certain conditions between Teignmouth Lighthouse and Teignmouth Pier during flooding and high tide stages, and particularly when spring tides are combined with southerly storm waves. Such a divergence is not predicted to occur at ebbing or low tide stages, or under waves arriving from the east, such that sediment transport to the north is dominated by southerly wave-driven transport. An example of diverging sediment transport occurring at this location can even be seen from aerial imagery, visible as suspended sediment plumes moving in opposite directions. This is demonstrated in Figure 2-4.



Figure 2-4 Demonstration sediment being transported in opposing directions during a flooding-high tide with southerly wave approach.

Historically, sediment transported south to north by the prevailing wave conditions is returned under easterlies, however, a reduction in easterly wave conditions, combined with the lower energy of the easterly waves (as explained in Section 2.2.2), is resulting in reduced return of sediment from the north.

In the outer estuary, the ebb tidal delta features a complex of sandbars and channels, with the main estuary channel oriented towards the south-east direction. The sandbars are known to be highly dynamic and interact with the shore in the lee of the delta; they migrate around the ebb shoal delta over a multi-annual cycle (described in Section 3.3 of Appendix A). The ebb shoal delta represents both a source and sink of sediment, and intermittently feeds the intertidal beach near the location of Teignmouth Lighthouse when the nearshore delta sandbars weld to the shore (acting as a sediment source).

Although fluvial sediment entering the Teign Estuary is significant, it tends to get trapped and stored within the mudflats in the upper reaches of the estuary and the remainder is flushed through the estuary mouth during high river flows.

Despite the ebb-dominance of the estuary, marine sediment is understood to be transported into the estuary in a flood tide, in combination with wave activity, where it becomes trapped and stored on The Salty (the largest sand bank in the estuary mouth).

2.2.7 Impacts of sea level rise

Sea levels are set to rise in the BMP region in the order of 100cm by 2090 for the RCP 8.5 and 95th percentile scenario (Met Office, 2025). As shown by the latest modelling completed for the Coastal Processes Baseline (see Appendix A), sea level rise will have an impact along the BMP frontage, however, the rate of change will be determined by overall net sediment balance within the coastal system, future storm climate, and other management activities such as the replacement or removal of the existing groyne field, and on the quantity and location of dredging activities.

- Beach levels on Shaldon Beach and Teignmouth Back Beach and are generally expected to stay within +/- 1 m of present-day levels, maintaining a usable intertidal beach over the next century. The exception to this is the seaward end of Shaldon Beach, which may drop below MLW by 2055-2080 if existing trends continue, meaning the intertidal beach there may become submerged.

- At Denn Spit, the positive sediment trend indicates that seaward barrier growth could outpace landward migration over the next century.
- Along the Teignmouth seafront, it is expected to lead to the progressive submergence of beaches, resulting in a decrease in their width, and this will be exacerbated by any existing beach lowering trends caused by alongshore sediment supply.
 - The northern half of the Seafront Beach may experience relatively modest beach lowering (0.5–1 m lower than present day) by 2120 and may prograde in places if existing positive trends in beach volume continue. This is expected to maintain a usable intertidal beach at most places in front of the trainline over the next century.
 - The southern half of the Seafront Beach is expected to experience accelerated beach lowering in future from coastal squeeze, exacerbated by existing negative trends in beach volume. Beach levels at the seawall between Teignmouth Lighthouse and Teignmouth Pier may lower to -2 to -5 m ODN by 2120, and the beach there may be submerged throughout the tide by 2030 to 2050.

2.3 Dredging and dredge disposal operations

The Teign Estuary channel is dredged to allow continuous access for ships to the Port of Teignmouth. Teignmouth Harbour and its approaches are susceptible to a build-up of material on the bar and the point. This challenges Teignmouth Harbour Commission (THC), as the Statutory (SHA) and Competent Harbour Authority (CHA), who have the responsibility to maintain the charted depth of the channel and overall responsibility for navigational safety .

Under the Teignmouth Harbour Order 1924¹, Teignmouth Harbour Commission (THC) (“the Teignmouth SHA”) are empowered to dredge, scour and excavate any portion of the foreshore and seabed to the extent necessary to secure a sufficient waterway and approach to the harbour for vessels using the same.

2.3.1 Capital dredging

Capital dredging is only employed as a single event to deepen and or change the Charted Depth, (reduced to CD) and requires a Marine Licence. Although capital dredging has been undertaken in the past, Teignmouth Harbour Commission has no immediate plans beyond that of maintenance dredging. Any plans in the future to capital dredge would be subject to a Marine Licence which would be published for consultation via the Marine Case Management System and can be seen via the public register under the control of the Marine Management Organisation.

2.3.2 Maintenance dredging and disposal

Maintenance dredging is undertaken to ensure the charted depth of the channel is maintained for safe access to vessels and is determined by a formal Navigational Risk Assessment. The Harbour Authority is empowered to conduct maintenance dredging without a Marine Licence under Section 75 of the Marine and Coastal Access Act 2009 and Marine Exemptions Section 5.1. THC undertakes dredging via two processes:

- **Grab hopper dredging** – where material is removed from the channel and redeposited at a designated spoil site. The depositing of the spoil requires a licence and following successful application from the Marine Management Organisation (MMO), THC have been granted permission to deposit 99,999 tonnes/annum of dredged material at Sprey Point. (as shown in Figure 2-5). However, this is seen as an

¹ https://assets.publishing.service.gov.uk/media/6753196714973821ce2a6d29/Teignmouth_Harbour_Order_1924.PDF. A revision order was submitted in 2023 and is understood to be in process;
https://assets.publishing.service.gov.uk/media/67531937e40c78cba1fb0085/Statement_in_Support_-_Teignmouth_Harbour_Revision_Order.pdf and
https://assets.publishing.service.gov.uk/media/6753192321057d0ed56a041b/Draft_Teignmouth_Harbour_Revision_Order.pdf.

upper limit only and the requirement for dredging is determined by the soundings and available depth at the time so that the Harbour Master and Pilots can make the best-informed decision.

- **Plough dredging (bed levelling)** - this process levels the seabed post certain types of weather/wind/tide to ensure safe navigation whilst maintaining frequent soundings to check the depth stays as published on British Admiralty Chart 26, as required for responsibilities under Open Port Duty (a legal obligation under the Harbours, Docks and Piers Clauses Act 1847). THC typically use their own plough dredger for this activity.



Figure 2-5 Map showing areas of the estuary channel dredged by THC and the dredge disposal location at Sprey Point (reference number PO070) (source: ADBP LLP, 2024).

Going forwards, the Harbour Authority has no plans to undertake anything other than maintenance, dredging, via grab hopper (20 days a year on average), and bed levelling for approximately 3 days a week depending upon conditions.

2.3.3 Dredged material

The dredged material contains predominantly coarse-grained sediment comprising brown gravelly sand with shell fragments (ADBP LLP, 2024). ADBP LLP (2024) conclude given the coarse-grained nature of the dredged material, it is not expected to contain significant concentrations of chemical contaminants such as metals, organotin compounds, polyaromatic hydrocarbons (PAHs), polychlorinated biphenyls (PCBs) or organochlorinated pesticides (OCPs). The MMO requires testing of samples which have been completed prior to the recent marine licence and will also be conducted during the endorsed period, as required by the present licence conditions.

As outlined in Section 1.3, new modelling for the current BMP was completed to appraise the influence of the existing dredging and disposal regime on coastal processes. The modelling and appraisal is reported on in full in the Coastal Processes Baseline (Appendix A) and the main findings summarised below.

- The model considered only grab, and not plough dredging, for two dredge quantity scenarios, and as part of the options modelling, a change to the disposal location was considered.
 - 45,000 tonnes per year; the maximum licenced dredge disposal permitted each year (as per the 2014-2024 MMO license).
 - 15,000 tonnes per year; a lower estimate of dredge material disposed of, based on quantities stated in a previous sediment recharge study conducted for Teignmouth.

- When grab dredging is included in the model, the predicted losses through transport gradients at the shore between Teignmouth Lighthouse and Teignmouth Pier are reduced.
- When the permitted maximum licenced disposal quantity (45,000 tonnes/year) is included in the model a significant increase in sediment bypassing to the north around Holcombe Headland occurs, along with a reduction in sediment feed from Ness Point to the Teignmouth frontage, and as much as 10,000 m³/year of sediment could be lost from Teignmouth's overall sediment budget.
- The study concludes:
 - That existing grab dredging activities are predicted to lead to a year-on-year loss of sediment to the Teignmouth frontage (assuming the maximum licensed quantity is dredged) that would not be expected to occur naturally.
- Relocating the dredged sediment disposal site to the nearshore area of Teignmouth Pier provided only limited sediment transport back to the beach under typical wave conditions, suggesting that natural onshore delivery is insufficient. However, this sediment could potentially serve as a cost-effective nourishment source in erosion-prone areas along Teignmouth Beach.

2.4 Lowering beach levels

2.4.1 Analysis of beach elevation data

Beach levels along sections of the Shaldon and Teignmouth frontage are observed to be lowering, and are particularly volatile along the Teignmouth open coast. This is noted in the project scope and has been investigated further with new analysis (completed for this BMP) of topographic (LiDAR) data sets (May 2007 & April 2022) and intertidal beach profiles (2007 to 2023 (2011 to 2023 for Shaldon Beach), to assess changes to beach elevation and volume. The findings are summarised below and presented in Figure 2-6 and Figure 2-7.

- A positive change in beach elevation and volume (accretion) along the north-eastern end of the Teignmouth seafront, from Sprey Point to Holcombe headland (profiles 6b00153–6b00191), with intertidal sediment gains of approximately +3 m³/m/year (alongshore range: +1 to +9 m³/m/year).
- A negative change in beach elevation and volume (erosion) from The Pavilions south along the coast, to The Point, with intertidal sediment losses as far as the lighthouse (profiles 6b00198–6b00212) of approximately -4 m³/m/year (alongshore range -9 to -0.4 m³/m/year).
- Relative stability between these locations (at beach profile 6b00198), suggesting a pivot point around which the beach is rotating.
- A negative change in beach elevation on the seaward side of The Point, but positive change on the seaward side between 2007 and 2022, a trend which is also observed from the latest monitoring from Spring 2025 (see Figure 2-8).
- Beach profile data shows the intertidal volume of the estuary side of The Point also dramatically increased following the 2013/14 winter storms. This is presumably through storm induced overwash of sediment from the Seafront Beach, rather than alongshore transport of sediment from the northern end of the Back Beach, as there is not a comparable change in volume at the other Back Beach profiles during the 2013/14 winter.
- Along back beach, the intertidal volume of Back Beach between Lower Point Car Park and Fish Quay has been much more stable over the last 15 years.
- Between 2011 and 2022, Shaldon Beach exhibits a beach rotation signal, with a significant increase in beach elevation at the western end of Shaldon Beach on the inside of the estuary, and a significant decrease in elevation at the eastern end just outside the estuary mouth. The net effect of the beach volume changes on Shaldon Beach) is that the western end of Shaldon Beach now has +8-9 m³/m more

intertidal sediment than at the start of the monitoring period in 2011, while the middle of Shaldon Beach adjacent to the estuary mouth has lost more than $-4 \text{ m}^3/\text{m}$ of intertidal sediment since 2011.



Figure 2-6 LiDAR difference plot showing beach elevation change for the period 2007–2022 along the Teignmouth open coast. Red colour indicates net loss of material and blue colour indicates net gain of material.

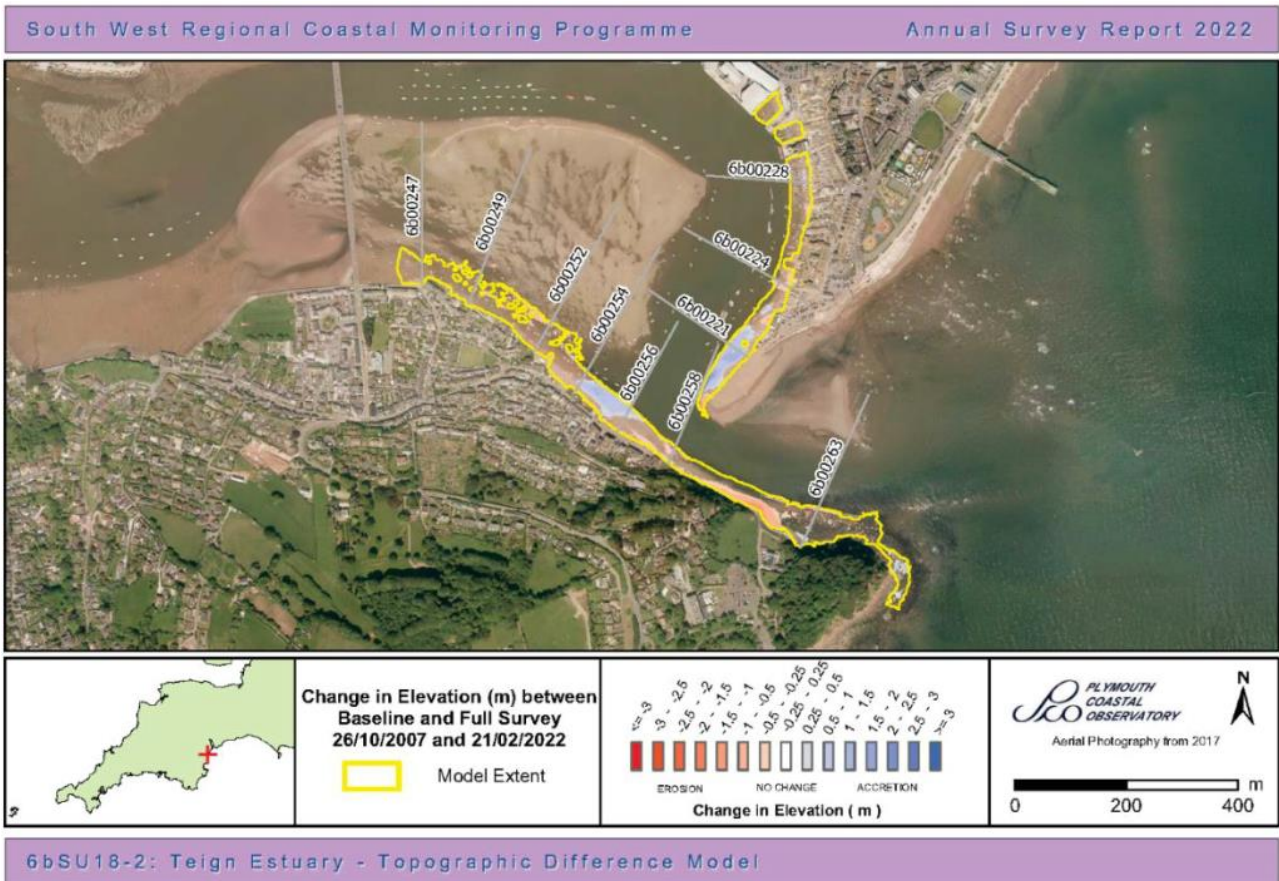

Figure 2-7 LiDAR difference plot showing beach elevation change for the period 2007–2022 on Teignmouth Back Beach and Shaldon Beach. Red colour indicates net loss of material and blue colour indicates net gain of material.

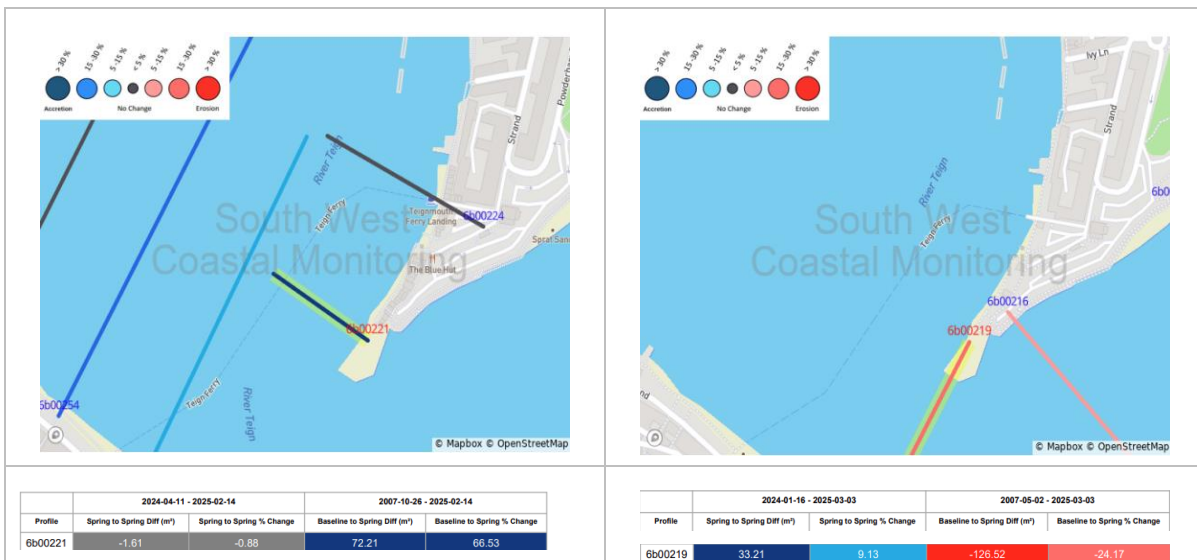

Figure 2-8 Beach profile change at The Point (source: https://swcm-dashboard.org/main_dash/6bSU18-1).

2.4.2 Potential causes of lowering beach levels

The findings of the new analysis completed for the Coastal Processes Baseline (outlined in the previous sections) have been used to identify the potential causes for observed beach lowering along Shaldon, Teignmouth Back Beach and Teignmouth seafront beaches.

- Shaldon
 - The observed increase in beach elevation at the western end of Shaldon Beach and decrease in elevation at the eastern end, is owed to **beach rotation** (as the beach responds and sediment transport respond to incident wave/tide conditions). Previous efforts were made in 2014 to reuse material collected during capital dredging operations for nourishment of the eroding eastern end of Shaldon beach. The material was dissipated over the subsequent tides and did not remain in place (TDC, Pers. Comms., 2025). Further to this, a limited programme of an annual beach profiling is undertaken by the Parish Council where modest quantities of fine sand which accumulates at the western end of the beach over a winter period, is moved to the main/eastern sections of the beach before the main summer season. However, the annual need for this suggests that this is not sufficient to counter the change in beach elevation occurring under beach rotation.
- Teignmouth Back Beach
 - Beach levels along Back Beach are considered to have remained **relatively stable** over the period of analysis (2007-2024).
- The Point and Teignmouth open coast
 - Beach levels on the estuary side of The Point have increased since 2007, and this is owed to **overwash and the rollback of the spit** into the estuary.
 - Beach levels from the seaward side of The Point to the Pavilions are lowering in response to:
 - **Ebb-tidal delta circulation** - sediment volumes arriving at the beach in response to the ebb-tidal delta circulation are reducing and not sufficient to maintain lowering beach levels at the shore.
 - **Alongshore transport divergence (due to flows)** – which occurs when tidal currents during flooding and high tide stages, particularly spring tides, and wave induced currents under southerly storms, cause sediment to be transported in two opposite directions between Teignmouth Lighthouse and Teignmouth Pier. This results in the movement of material to the south and the north.
 - **Alongshore transport gradient** – where there is a net movement of material from the beach between Teignmouth Lighthouse and Teignmouth Pier to the north (in response to the predominant southerly wave energy).
 - **Balance of easterly vs westerly wave conditions** – an increase in the dominance of southerly waves, resulting in a net transport of material from south to north along the Teignmouth Open Coast, combined with a reduction in easterly wave conditions, which would otherwise act to transport any northerly driven sediment back to the south. The net effect is a rotating beach, with beach erosion to the south and accretion to the north, with the pivot point located close to The Pavilions.
 - **Change to sediment transport pathways** – where sediment is believed to be transported to the north and around the Holcombe Headland, and south to the Ness under easterly storms, with evidence for a drift divide at Sprey Point lacking.
 - **Dredging activities** – it is proposed that removal of sediment via dredging activities could (i) reduce the volume of material within the ebb-tidal delta and therefore the quantity of material available to be transported onshore via the ebb-tidal delta circulation; and (ii) it is inferred from the modelling write-up that increased transport of sediment around Holcombe Headland when

dredging disposal is considered could be a result of adding material to that being transported north as result of southerly directed waves and tidal currents.

2.5 Coastal defence condition

The coastal defences along the Shaldon, Back Beach and Teignmouth frontage have been built at different times, with different constructions, maintenance regime and owners (Binnies, 2024). A summary of the most recent schemes constructed along the BMP frontage is presented in Table 2.2.

Table 2.2 Recent coastal schemes along the BMP frontage.

Location	Name of Scheme	Construction Date	Details of Scheme	Cost of Scheme	Properties Protected
Shaldon	Shaldon and Ringmore tidal flood defence scheme	2010-2011	Seawall repair and improvements, with flood gates and steps across the wall	£8.3 million	453
Back Beach	Teignmouth Estuary (Back Beach) Tidal Defence Scheme	2011-2013	New seawall and improvements to existing, flood gates, New public access ramps and demountable flood boards	£3.8 million	497
The Point	Teignmouth Flood Defence Scheme	2017	Repair, renewal and strengthening of seawall around The Point, including steel sheet piles + concrete capping beam	£1.3 million	400

As identified by ongoing investigations and site monitoring, the condition of the these defences vary, and in some places an observed trend of beach level lowering (described in Section 2.4) is further threatening the integrity of the defences. The Teignmouth seawall has failed and repaired in 2015 and 2017, and today the groynes are currently maintained only for the purpose of Health and Safety, rather than function (Environment Agency, 2024). As outlined in Section 1.4, the Environment Agency are seeking to address the condition of the Teignmouth seawall and groynes via the Teignmouth Remedial Works project (Section 1.4).

In support of the Teignmouth Remedial Works project and the current BMP, a number of coastal defence assessments have been completed. These are described below, along with a summary of the key findings and issues concerning coastal defences condition.

- Teignmouth Coastal Defences Engineering Assessment reports (Binnies, 2023, 2024) – included an assessment of stability of the seawall for six of seven areas along the length of the Teignmouth open coast accompanied by a review of beach levels, defence form (history) and defence details (beach level, construction, maintenance, condition).
- Defences Baseline (Appendix B) – for the full BMP frontage, includes a detailed review of the history of flood and coastal erosion defences, a new inspection and assessment of the condition and residual life of the defences. And specifically for the Shaldon and the Teignmouth frontages, an overtopping assessment, and for Teignmouth Back Beach, an assessment of tidal flood risk.

The defence studies show:

- The condition of the seawalls/floodwalls along the length of the BMP frontage varies from fair to good, however, owed to lowering beach levels, the seawall in the vicinity and either side of the pier, residual life

is reduced and is at risk from sliding and over-turning (Binnies, 2024). Binnies suggest solutions to help stabilise the seawall could include, inter alia, anchorages and or a deeper toe.

- Ongoing deterioration of all 13 wooden groynes, which were assessed to be in poor condition (Appendix B), and have either failed or are at risk of failure (Environment Agency , 2023).

2.6 Receptors and damages

Potential flooding, as discussed in Section 2.1, puts many receptors at risk of damage, including residential and non-residential properties. A new assessment of flood risk damages (to a selection of receptors) was completed for the BMP and combined with the options costing to determine cost benefit ratios. Full details are presented in the Economics Baseline (Appendix D) and the Options Appraisal report (Appendix F). Assuming that all defence heights remain the same , the Present Value damages over a 100 year period for the BMP frontage are estimated to be in the region of:

- Present Value damages for Shaldon: **£2.7 million**.
- Present Value damages for Back Beach and Teignmouth: **£53.3 million**.

2.7 Considerations for option implementation

2.7.1 Responsibilities for management of the coastline

Responsibility for the management and operation of activities within the BMP area varies depending upon the activity and ownership. Relevant roles and responsibilities are summarised in Table 2.3.

Table 2.3 Assigned responsibilities for flood and coastal erosion risk management activities

Coastal Defence / Management Activity	Ownership	Assigned Responsibility	Covered by BMP
Structures and tunnel portal at Ness Beach	TDC	TDC	X
Shaldon (tidal defences)	Environment Agency	Environment Agency	Y
Seawall Marine Parade, Shaldon and beneath the Ness Hotel, Shaldon	TDC	TDC	Y
Teignmouth Port infrastructure	ABP		X
Morgan Giles Quay, Fish Quay and Polly Steps, Teignmouth	TDC	TDC	Y
Back Beach (tidal defences)	Environment Agency	Environment Agency	Y
Stone groyne projecting from the Point and training wall on southern shore	Historical structures ownership not confirmed – THC/Crown Estate/TDC	Historical structures ownership not confirmed – THC/Crown Estate/TDC	Y
Southern extent of Teignmouth seafront defences (The Point Car Park)	TDC	TDC	Y
Central Teignmouth seafront and Back Beach Tidal Defences, including groyne field	Environment Agency	Environment Agency	Y

Northern extent of Teignmouth seafront defences, including groyne field	TDC	TDC	Y
Sea Wall Holcombe to Eastcliff Teignmouth	Network Rail		X
Residual groyne arrays (now largely defunct) in front of rail asset -	Network Rail		X
Several coastal outlet pipe structures -	SSW		X

2.7.2 Funding sources

In taking forward the preferred option and management approach for the BMP frontage, consideration will need to be given to how it could be funded. Funding for flood and coastal erosion risk management can be achieved via a number of sources.

2.7.3 Implications on the environment

The following sections summarises the key activities identified by the Environmental Baseline (Appendix C) that will need to be considered when implementing the preferred management approach.

- Early consultation with Natural England will be required as there is a potential requirement for a Habitats Regulations Assessment to assess impacts of proposed beach management activities on the integrity of international nature conservation sites.
- Further to the existing MMO license for the placement of dredged material, there may be a requirement for further licenses and consents. Early consultation with relevant consenting organisations in a timely manner will help to minimise the risk of delays in being able to implement future works
- Any future works should be programmed to minimise access, noise and visual disturbance impacts on amenity users, residents and businesses where possible and ensure safe public access.

Further to this, consultation undertaken for the Teignmouth remedial works, which flagged a number of items that should be considered when taking forward the preferred management approach:

- There are potential environmental impacts associated with construction on bathing water quality and fisheries, and this should be included within any risk assessments. For example, the impact of nearshore habitats of sediment placement on eel grass beds.
- Seek to identify wider environmental enhancements within any future design (for example artificial features to enhance the sea wall).
- Consider that planning applications may trigger requirements for Biodiversity Net Gain (BNG).
- Shaldon, Back Beach and Teignmouth are popular amenity areas which will reduce the construction window and increase associated risks and costs.

2.7.4 Regulations

Environmental Impact Assessment (EIA) procedures in EC countries are based on the European Community Directive 'The Assessment of the Effects of Certain Public and Private Projects on the Environment' (85/337/EEC) as amended by the Council Directive 97/11/EC.

The Directive was implemented in the UK through various regulations. Those regulations relevant to this BMP are considered to be:

2.7.4.1 The Town and Country Planning (Environmental Impact Assessment) Regulations 2017

These EIA Regulations apply only to the environmental impact assessment ("EIA") of certain developments which are given consent for development under the town and country planning laws of England.

The Town and Country Planning (Environmental Impact Assessment) Regulations 2017 revoke and replace the Town and Country Planning (Environmental Impact Assessment) (England and Wales) Regulations 2011, as amended, in England.

Construction works / any capital scheme may require some form of planning consent from TDC. It is recommended that the local planning officer be consulted at the time when the works/ a capital scheme is being developed to determine the most appropriate route for planning consent.

Above the MHWS the planning authority would act as the Competent Authority and planning permission would be sought. An application under these circumstances would also require consideration under the Town and Country Planning (Environmental Impact Assessment) regulations 2011. In this regard, TDC would likely act as the Competent Authority.

2.7.4.2 The Marine Works (Environmental Impact Assessment) Regulations 2007 (as amended)

These regulations make provision for the requirement of EIAs to be carried out prior to the granting of consent of certain regulated activities in UK waters and UK controlled waters.

2.7.5 Licences and consents

The following sections sets out relevant licenses, consents that would be required to implement the flood and coastal erosion risk management regime recommended in this BMP (see Section 3) and the processes to obtaining them, namely capital works or beach recycling:

- Marine Licence from the Marine Management Organisation (MMO) under the Marine and Coastal Access Act 2009 for works below Mean High Water Spring (details of THC's MMO license is discussed in Section 2.3).
- Harbour Works Licence under the Teignmouth Harbour Order 1924.
- Planning application under the Town and Country Planning Act 1990 for works above Mean Low Water.
- Crown Estate Licence – for works along the majority of the foreshore within the study area, which is owned by the Crown Estate.
- PRoW diversions and closures should any be affected by future beach management interventions.
- Environmental Permit for Flood Risk Activities.

Discussions should be held with the relevant consenting organisations in a timely manner to ensure that all requirements of licence/consent applications are confirmed and addressed in order to minimise the risk of delays in being able to implement future works. These discussions should also assess the applicability of progressing a licence application through the streamlined process defined in the Coastal Concordant for England published in November 2013 (Defra, 2013).

As part of the process of obtaining a Marine Licence and planning application for undertaking beach recharge or other capital works, consideration of The Marine Works (Environmental Impact Assessment) Regulations 2007 (as amended) and the Town and Country Planning (EIA) Regulations 2017 respectively will be needed to determine whether an environmental impact assessment is required. A Water Environment Regulations Screening assessment would also be required to support these consent applications. The scope of any such assessment would require consultation with the Environment Agency.

There is one European site with potential connectivity to the study area, designated under The Conservation of Habitats and Species Regulations 2010. Therefore, the Competent Authority would likely be required to undertake a Habitats Regulations Assessment screening on any proposed works along the BMP frontages at Teignmouth and Shaldon.

2.7.6 Relevant planning documents and local studies

- **Durlston Head to Rame Head (South Devon and Dorset) Shoreline Management Plan (SMP)** (Halcrow, 2011) is a coastal management document formally approved by Defra, and was adopted in 2011.
 - The SMP policy for the BMP frontage is Hold the Line for the long term (to 2105), with the exception of The Point, which is Managed Realignment.
- **2013-2033 – Teignbridge Local Plan (2014)** outlines the strategies and policies relevant for flood and coastal erosion risk management activities. See: <https://www.teignbridge.gov.uk/media/1669/local-plan-2013-33.pdf>
- **Teignmouth Neighbourhood Plan 2018-2033 (2022)**. See: <https://www.teignmouth-devon.gov.uk/teignmouth-town-council-neighbourhood-plan-2018-2033/>.
- **South Devon Catchment Flood Management Plan (CFMP)** (Environment Agency, 2012) acknowledges sources of flooding from rivers in the South Devon Catchment. The Teign catchment is a South Devon 'Focus Area'. An evidence review is planned in 2024, with a view to update Teign Catchment plan (as part of the South Devon Catchment Partnership) (Environment Agency, 2023).
- **South West Inshore Marine Plan (2021)** provides a framework that will shape and inform decisions over how the areas' waters are developed, protected and improved over the next 20 years. See: <https://www.gov.uk/government/publications/the-south-west-marine-plans-documents>.
- **South West River Basin District Management Plan 2021-2027 (2022)** was prepared under the WFD as an update to the original programme produced in 2009 as part of a series of six-year planning cycles. It contains actions to improve the ecological status of water bodies in river basin catchments, including coastal waters from mean low water up to 1 nautical mile from shore. See: <https://www.gov.uk/government/publications/south-west-river-basin-district-flood-risk-management-plan>.
 - All BMP activities need to comply with the requirements of this plan. Under the WFD, the BMP options will need to ensure that they do not cause or contribute to deterioration in water body status' or 'jeopardise the water body achieving good status'.
- **Coastal Access Program:** Natural England has investigated how to improve coastal access along a 109 km stretch of the South West Coast Path between Kingswear and Lyme Regis. On 18 March 2021, the Secretary of State announced their decision to approve this stretch of the England Coast Path between Kingswear and Lyme Regis.
 - Between Maidencombe and Holcombe, no improvements to the route are proposed.
- **National Planning Policy Framework:** The National Planning Policy Framework (NPPF) was published on 27 March 2012, revised in December 2023 and sets out the government's planning policies for England and how these are expected to be applied.
 - Chapter 14. Meeting the challenge of climate change, flooding and coastal change. Paragraphs 176 to 179 are particularly relevant to the Teignmouth BMP.

3. Management and Maintenance Regime

In line with the aims and objectives of the BMP (outlined in Section 1.2), the following section sets out the management and maintenance regime to reduce the flood and coastal erosion risk to the BMP frontage for the next 20-30 years. The regime has been developed in conjunction with a robust options appraisal process to provide the preferred option with the best balance between technical viability, environmental acceptability and economic case, taking into account any technical constraints and opportunities.

The preferred option is set out in Section 3.1.1 below. Full details of the options appraisal are presented in the Options Appraisal Report, which is provided Appendix E.

The subsequent sections describe the maintenance regime that is necessary to implement the preferred option and ensure that the beach and defences at Shaldon, Back Beach and Teignmouth continue to provide adequate coastal flood and erosion risk management of the area in the immediate future.

3.1 Future management approach

3.1.1 Preferred option

The preferred option for future management of the BMP frontage is: **Option 3, Improve 2 - improve SOS, sustain SOP**, see Table 3.1 for full details of the option.

This option assumes the wall is raised in year 2028. If a setback wall is preferred to wall raising, then only repairs to the existing would be undertaken in 2028. This option could be adjusted to raise the wall/install a setback wall later, which require a review of the costs used in the options appraisal.

Alongside this, it is recommended that options to beneficially use the material dredged from the estuary channel and the eroding cliffs landward of the railway are undertaken with immediate effect, as outlined below.

3.1.2 Beneficial used of dredge material

The future management regime of the BMP frontage should allow for recycling and placement of material dredged from the estuary approach channel at an alternative disposal location to Sprey Point. As suggested in the Coastal Processes Baseline, material could be better placed on the nearshore of the Teignmouth open coast and would be a cost-effective solution to contribute toward reducing beach lowering there. It is recommended that the material is placed adjacent to the Teignmouth Pier, within the groyne bays immediately to the north or south, where beach levels are particularly low, and is far enough away from the channel that some time passes before it could potentially be transported back to the south and into the channel again. Sediment sampling of the dredge material completed for the recent Marine license application (see Section 2.3) concludes that the sediment is unlikely to be contaminated and would therefore be safe to use.

3.1.3 Beneficial use of eroded cliff material

In addition, it is understood that Network Rail undertakes periodic work to remove cliff fall debris from the area between Teignmouth and Sprey Point when it falls onto the railway line. This cliff fall debris is presently removed from site. However, it could more beneficially be placed over the seawall and onto the beach fronting Network Rail's wall. This would add sediment to the coastal system just as it would do if the seawall was not present. Discussions should therefore be held with Network Rail and the Marine Management Organisation to investigate the viability of this activity and the possibility of this change in Network Rail operations being implemented.

Table 3.1 Preferred option for BMP frontage.

Location	Existing Structures / Proposed Structures	Measure Detail / Implementation (SoP=Standard of Protection)
Teignmouth Open Coast	Existing seawall (masonry wall - south, concrete recurve wall, concrete wall, masonry clad concrete wall - north).	Raise the height of the seawall to achieve current levels of overtopping in year 100. If existing wall not suitable for raising consider set-back wall or construct new wall.
Teignmouth Open Coast	Existing sheet piles.	Repair and maintain the existing toe piles as they reach the end of their RL, replace sheet piles as they fail due to corrosion with same standard of service (i.e. same length / thickness).
Teignmouth Open Coast	New toe protection works along existing sheet piled toe (gabions, timber cribwork, rock armour, sheet piles)	Construct new toe protection at the bottom of the existing wall (below the bottom step) along the entire length of the Teignmouth Open Coast seawall removing reliance on beach to reduce risk from scour and undermining.
Teignmouth Open Coast	New timber groynes.	Construct a new and improved groyne field that will retain a higher beach. e.g. by adjusting groyne length/height/spacing.
The Point	The Point breakwater	Upgrade existing structure along same alignment so that it is as effective in year 100 as it is today (e.g. by extending length and/or raising).
Teignmouth Back Beach	"Existing flood defences (Concrete flood walls, masonry flood walls, masonry property walls, masonry property walls with glazing, rendered property walls, engineered high-ground, flood gates x8, demountable flood board x1).	Raise the height of existing flood defences to achieve current levels of overtopping in year 100. Existing flood warning services continue."
Teignmouth Back Beach		Construct new toe protection at the bottom of the existing wall (below the bottom step) along the entire length of the Teignmouth Back Beach seawall removing reliance on beach to prevent undermining. Proposed structure extents designed to provide existing SoP against undermining (provided by the existing beach) in year 100.
Shaldon	Existing Flood Warning Direct (FWD) (EA, 2010)	Raise the height of the seawall to achieve current levels of overtopping in year 100. If existing wall not suitable for raising, construct new wall.
Shaldon	Existing Automated telephone flood warning service"	Construct new toe protection at the bottom of the existing wall removing reliance on beach to prevent undermining. Proposed structure extents designed to provide existing SoP against undermining (provided by the existing beach) in year 100.

3.2 Structure maintenance - immediate

The latest defence inspection undertaken for the BMP, and included in full in Appendix B, identified a number of issues, which in respect of public safety need to be addressed in the immediate future: these are listed in Table 3.2.

Table 3.2 Immediate action required for existing defences

Asset Inspection Observation
Due to an absence of direct access steps people were observed climbing over the steel outfall pipe at the north end of Teignmouth to access the beach further to the north-east towards Sprey Point.
Some loose fixings are present on Groyne 2 where planks have been lost to the wave action and abrasion by sediment. These present movable and/or sharp hazards.
Some of the concrete access steps over the timber groynes under the responsibility of TDC contain cracks and general damage which may worsen over time presenting a trip hazard.
The beach access steps at Groyne 7 have been worn, and now present an undulating surface for people wishing to use the access steps. Specifically, the stone steps at the base of the access at Groyne 7 have been lost, creating the same problem.
The removal or loss of one of the large cylindrical braces on Groyne 10 has left an exposed timber support separate from the main timber structure presenting a potential trip hazard.
Further work to address public safety issues should be undertaken based upon observations during future visual inspections. These routine visual inspections should also include these various private defences accepting that Network Rail will continue to inspect their defences between Teignmouth and Sprey Point.

3.3 Structure maintenance – future

3.3.1 Existing defences

Routine maintenance works to existing defences at Shaldon, Back Beach and Teignmouth should be guided by ongoing inspections, as set out in Section 4.1. When either routine inspection or a post-storm survey identifies a defect in the defence (e.g. a crack in the defence) or damage to public safety aspects of the defence (e.g. buckled hand railings or trip hazards etc.) then the following steps are to be followed:

1. Increased defect monitoring – should any defects be identified then it may be appropriate to implement an increased level monitoring rather than immediately undertaking remedial works. This could also involve the use of additional monitoring devices such as crack gauges. This step should only occur if the identified defect is not considered an immediate safety risk (i.e. this step is optional and may or may not occur prior to Step 2).
2. Remedial works – once an identified defect is considered to be in need of remedial work, then the design of remedial works should be undertaken and an appropriate repair specification generated. To ensure consistent information on repairs undertaken is recorded, a defence repair record should be completed and retained for future information.

3.3.2 Tidal flood defences

Maintenance of the tidal flood defences constructed at Shaldon and Back Beach are to be guided by the Teignmouth Sea Defence Scheme (SDS) Sustainable Asset Management Plan (SAMP), reference FR/13/S260 (Environment Agency, 2013).

3.4 Beach maintenance – trigger levels

As well as an amenity benefit, the beach at Shaldon and along the Teignmouth Open coast helps to (i) protect the seawall from scour, which could in turn lead to corrosion of the sheet piles and undermining or destabilisation (sliding/overtopping) of the seawall; and (ii) reduce the volume of overtopping, which can result in risks to public safety and flooding.

This extent of the protection provided by the beach is very much dependent on beach levels at the seawall toe where there is a tolerable level below which scour could cause undermining or destabilisation, as well as increase overtopping.

To help mitigate this risk, for the Teignmouth Open Coast only, beach trigger levels for both scenarios are provided in the following sections, and should be used to instigate any required maintenance (Section 3.3.1) and monitoring measures (Section 4).

3.4.1 Seawall stability trigger levels

New sea wall stability trigger levels have been generated for this latest BMP using a combination of seawall failure analysis, scour analysis and beach level data, as outlined below.

- Seawall failure analysis completed by Binnies (2024) for the Teignmouth Remedial Works project, which provided the beach level required to give a factor of safety of 1.0 (i.e. for failure to be likely due to sliding or overturning) with the toe pile in place (Table 3.3). A map showing the related areas numbers is provided for reference in Figure 3-1.
- Scour analysis completed for the previous BMP (CH2M, 2013), specifically the 1:100 return period, to align with the 1:100 year seawall Standard of Protection (SoP) trigger levels (See Section 3.4.2).
- A new assessment of beach monitoring data to determine the largest inter-survey beach level fall in the past five years.

Alarm and crisis levels have been defined for a 1:100 year return period for the Teignmouth Open Coast, which should be used when monitoring beach levels and determining an appropriate course of action to ensure the stability of the existing seawall is not compromised.

- Crisis level – when the beach level at the seawall falls to a level where there is a risk of scour and undermining during a 1:100 year storm event. Immediate action is required.
- Alarm level – the Crisis level plus a buffer equivalent to the largest observed inter-survey fall in beach levels over the past 5 years. Increased monitoring should be undertaken to promptly identify if beach levels are approaching Crisis level. (recommended beach monitoring approach is set-out in Section 4.2).

Table 3.3 Trigger levels for the Teignmouth Open Coast beach.

Area	Profile	FoS = 1 (mOD)*	1in100 scour depth (m)**	Largest inter survey drop in past 5 years (m)	Alarm (mOD)	Crisis (mOD)
2	6b00194 to 6b00196	-3.5	1.72	-0.95	-0.83	-1.78
3	6b00197 to 6b00200	-0.3	1.72	-0.95	2.37	1.42
4a	6b00201 to 6b00205	-1.25	1.97	-1.48	2.2	0.72
4b	6b00206 to 6b00211	-1.25	1.86	-1.12	1.73	0.61
5	6b00212 to 6b00214	-4	1.79	-1.73	-0.48	-2.21
6	6b00215 to 6b00216	-3.7	1.75	-0.9	-1.05	-1.95

- * FoS (Binnies, 2024).
- **Scour depth (CH2M, 2013).



Figure 3-1 Seawall stability assessment area division (Binnies, 2024).

3.4.2 Seawall Standard of Protection (SoP) trigger levels

The beach trigger levels adopted by the previous 2014 study to achieve a certain SoP against wave overtopping for the Teignmouth open coast should continue to be used. No new overtopping analysis has been completed for the present BMP and a comparison of the overtopping results generated for the 2014 study and the latest overtopping by JBA (2021) shows little difference between them. Therefore the 2014

beach trigger levels will still apply. Trigger levels have not been derived for Shaldon for the current BMP owed to a lack of data and it is recommended that this is taken forward in the BMP Action Plan (Section 5).

The 'alarm' trigger level was calculated by determining the beach level at the toe of the defence that would limit overtopping discharge rates to 200 l/m/s for each frontage during 1 in 200 year extreme events.

The 'crisis' trigger level was calculated by determining the beach level at the toe of the defence that would limit overtopping discharge rates to 200 l/m/s for each frontage during 1 in 100 year extreme event conditions. This will ensure that the 1 in 100 year Standard of Protection is retained, protecting the assets within Teignmouth.

The trigger levels along the Teignmouth frontage at six beach profile locations (refer to Section 4.2.1) are presented in Table 1.1.

Table 3.4 Alarm and crisis trigger levels at different points along the Teignmouth frontage (CH2M, 2014).

	Beach crest level against seawall (mOD) by beach profile location					
	6b00191	6b00198	6b00204	6b00209	6b00212	6b00216
Alarm Level (mOD)	1.33	0.50	2.00	1.80	2.14	1.57
<i>Alarm Level as drop distance from wall crest (m)</i>	<i>1.47</i>	<i>4.40</i>	<i>2.70</i>	<i>2.90</i>	<i>2.46</i>	<i>3.63</i>
Crisis Level (mOD)	1.06	0.29	1.52	1.52	1.86	1.16
<i>Crisis Level as drop distance from wall crest (m)</i>	<i>1.74</i>	<i>4.61</i>	<i>3.18</i>	<i>3.18</i>	<i>2.74</i>	<i>4.04</i>

3.5 Flood warning and response procedures

Flood warnings and responses are co-ordinated by the Environment Agency's Flood Incident Management Duty Officer based in Exeter. The Duty Officer procedures are available through the Environment Agency's South West Incident Management (SWIM) website (www.imflooding.co.uk) – note this is a secure site for approved Environment Agency users only and all duty officers have access to the SWIM website. Up-to-date hard copies of the procedures are held in the Environment Agency Area Incident Room in Exeter.

3.6 Implementation of management activities

Should any works described in Sections 3.2 to 3.4 be required along any part of the BMP frontages, the items detailed below should be considered when implementing any associated works.

3.6.1 Plant requirements

No specific plant requirements are defined in this BMP.

The plant required to undertake capital works will depend upon the nature of the works and should be considered by the designer and contractor at the time any such works are to occur along the frontages covered by this BMP. A key factor in this regards will be the capacity of the access points (refer to Section 5.5.2).

3.6.2 Access

When any works are to be carried out along the Teignmouth or Shaldon frontages, consideration will need to be given as to the access requirements given the size of any plant being considered, and with regards to the soft (mud) foreshore conditions and limited tidal window for working along the respective frontage.

However, the following locations are likely to be suitable for plant access to the beach:

- Between Sprey Point and Teignmouth, access via the slipway at Sprey Point (note, will need to liaise with Network Rail to gain access approval).
- At Teignmouth, access via The Point Car Park slipway. However, it is noted that access to the beach with machinery via the Lower Point car park ramp has become difficult due to the sand level dropping below the level of the bottom of the ramp. (Environment Agency, 2024).
- Shaldon, access through the flood gates from the Strand / Marine Parade (road that runs behind the beach) onto the beach.

3.6.3 Public access, amenity and safety

Beach and coastal defence works, when they are required, should avoid the peak holiday season, weekends and public holidays where possible. This will minimise the impact of works on beach users and will reduce the minor risk to public safety that such work would pose. In order to ensure the safety of the public whilst works are being carried out, restrictions on public access to the areas of the beach being worked on should be implemented, with alternative routes provided if possible.

Experience elsewhere has shown that closing the beach entirely is likely to be impractical, and it is suggested that a banks-man is present with each machine, and that spare personnel along with signage are employed to direct public access to safe sections of the shoreline during works.

Information boards should be displayed whilst the works are being carried out to explain what is being done and why. This will also serve to improve public education.

3.6.4 Notifying others

In addition to communicating effectively with the public, it is recommended that explicit notification of any works, and contact details should there be any queries, be provided to the following organisations/groups as appropriate depending upon the location where works are occurring:

- The local Town and Parish Councils;
- The Crown Estate;
- Teignmouth Harbour Commission;
- Local fishermen and those people who have a day to day interest in what is happening along the frontage where works are to occur, i.e. any businesses that may be affected;
- Local residents directly affected by any road or access closures along the frontage when works occur;
- Natural England (in relation to nature conservation and coastal access interests); and
- Devon Historic Environment Service (in relation to historic environment interests).

4. Monitoring Regime

To support the implementation and future management of the BMP frontage, it is recommended that a regime of structure and beach monitoring is put into place to ensure the coastal structures perform to design standards and beach levels are maintained, do not lower further, and if they do, action is taken to mitigate or protect against them.

The data collected via monitoring activities, can also be used to:

- Assess beach morphology and change.
- Improve the understanding of the coastal processes operating along the Teignmouth BMP frontage and wider coastal area.
- Guide future modelling activities when taking forward the preferred option to appraisal/business case stage.
- Identify the cumulative effects of changes to the Shaldon, Back Beach, Point and Teignmouth frontages in the context of the wider BMP area.

4.1 Structure monitoring

4.1.1 Annual visual inspection

A visual inspection of all of the structures along the BMP frontage should be undertaken on a yearly basis. This should occur during the spring of each year to allow identification of any issues so that subsequent completion of any maintenance works required can be completed prior to the busy summer period, thus avoiding impacting on the amenity use of the beach.

It is recommended that the annual inspections are undertaken in accordance with Condition Assessment Manual (Environment Agency, 2006), to check overall defence condition and identify any defects that may require further maintenance. The Environment Agency's AIMS database should be updated with the findings of the inspection.

Visual checking of access ramps, steps, hand rails etc. should also be undertaken to ensure that these are in a safe condition of public use. This should be carried out in accordance with the Environment Agency's public safety risk assessment operational instruction.

Where possible, the annual inspection could be undertaken in combination with the recommended visual walkover inspection of the beach as a means to check beach triggers levels.

4.1.2 Detailed inspection

More detailed inspections of the defences, such as those undertaken by Binnies (2024) could be undertaken and planned for going forwards. This should form part of the management plan for the preferred option and potential outcomes of the Teignmouth Remedial Works project.

4.1.3 Post-storm visual inspection

Visual inspections to monitor structures after storms should be undertaken to inspect for damage and any potential health and safety risks. Appropriate action would be to undertake additional monitoring or safeguard the structure and implement any necessary emergency/temporary works. A proforma should be developed and utilised for all reporting going forwards.

4.1.4 Defect monitoring

In response to monitoring triggered by observed defects (see Section 3.3.1), ad-hoc or planned monitoring of a particular defence or part of a defence should be undertaken.

4.2 Beach monitoring

The beaches at Shaldon, Back Beach and Teignmouth are currently monitored as part of the South-West Regional Coastal Monitoring Programme (SWRCMP)². The data and analysis completed for the programme should continue to be used to monitor the BMP frontage. It is recommended that this is supplemented with additional monitoring between those surveys to provide a higher resolution of data to inform coastal managers on how the beach has responded to storm events and positioned against the BMP beach trigger levels (see Section 3.4). Should TDC have sufficient resource, it would be of benefit to bring together this information within an annual report to provide a complete picture of beach change over time.

4.2.1 Annual monitoring reporting (using South-West Regional Coastal Monitoring Programme (SWRCMP))

Data and analysis collected for the South West Regional Monitoring Programme is available via their interactive platform (available here https://swcm-dashboard.org/main_dash/) and provides an excellent resource of information to assess how the beaches along the BMP frontage have changed over time. The relevant units to the BMP frontage are:

- **6bSU18-2 – Teign Estuary** – which covers Shaldon, Back Beach and the Point (https://swcm-dashboard.org/main_dash/6bSU18-2/); and
- **6bSU18-2 – Teignmouth** – which covers the Teignmouth seafront (https://swcm-dashboard.org/main_dash/6bSU18-1/).

It is suggested that the following data is used to inform the annual monitoring reporting:

- **Wave, tides and meteorological data** – each year, a series of hydrodynamic data is processed and analysed and reported on here.
- **Topographic data:** twice a year during the Spring and Autumn, discrete and repeated beach profiles are surveyed, and every five years, the full suite of profiles are surveyed. The data is used to generate beach profile cross-sections, from which changes in cross-sectional area and accretion/erosion trends are identified, and topographic difference plots, which show beach elevation change in plan-form and associated volume change between various dates.
- **Post-storm topographic data:** the SWRCMP also undertake post-storm surveys, which can be used to assess how the beach responded to storms. Wherever possible, the data should be processed immediately after the storm, and assessment made against the trigger levels identified within the BMP to determine if any action is required.
- **Aerial photography, bathymetry, LiDAR:** also collected under the SWRCM, and if required can provide an additional source of data to investigate beach and shoreline change.

4.2.2 Post storm site visits

Following any storm, a walkover survey of the beach should be undertaken by TDC and/or the Environment Agency to assess the status of the beach and appraise potential recovery. If possible beach levels should be monitored (to supplement those undertaken by the SWRCMP) and to identify whether alarm and crisis trigger levels have been reached and whether any maintenance/emergency actions are required.

² <https://southwest.coastalmonitoring.org/>

It is also recommended following a storm event to consider forecasts of subsequent storm events to:

- Identify if these could result in further erosion of the beach; and
- If so, continue to monitor the beach for any further erosion and appraise the beach against the trigger levels.
- If necessary take remedial action to make the relevant structure safe.

4.2.3 Trigger level monitoring and response

4.2.3.1 Alarm level

If the Alarm Level (refer to Section 3.4) is reached, the primary response will be to undertake more frequent monitoring of the beach levels through visual inspection and analysis of beach profile data to determine if it is persistent or if it is merely a temporary occurrence as a result of naturally dynamic beach level fluctuations that are known to occur along the frontage at Teignmouth in particular. This more frequent monitoring will ensure that if the beach level lowers further to the Crisis Level, then this will be observed in a timely manner and not be missed by less frequent planned beach profile surveys.

4.2.3.2 Crisis level

If a Crisis Level (refer to Section 3.4) is identified as being reached, the immediate task would be to carry out a visual inspection of the beach to validate the survey data and check that it is representative of the general beach area (i.e. not a localised 'low' point). If the Crisis Level is shown to be a general problem to be addressed, then timely action will be required to safeguard the integrity of the seawall.

Ultimately the response to the Crisis Level being reached along the seawall will be for capital works to be carried out. If not already in process, then planning and implementation of capital works should begin.

However, it is likely that the Crisis Level will occur as a result of a storm event that erodes a large amount of beach material over a short period of time. Therefore, whilst the ultimate response of capital works is being planned and implemented, a temporary measure would need to be put in place.

4.3 Beach recycling logs

Whenever beach recycling works are undertaken (see Section 3.1.2 and 3.1.3), beach recycling logs should be maintained by those undertaking the works, with the records then being passed to TDC, EA and SWRCMP. This information will allow future analysis of beach area, volume and topographic change to more accurately account for the effects of beach recycling work and will enable the underlying natural beach movements to be identified.

This could be supported by completing a pre- and post-beach recycling survey each time material is deposited.

4.4 Environmental monitoring

The study area covered by this BMP is within the vicinity of a number of environmental designations, including regionally important geological site, designated bathing waters, and local landscape designations (refer to the Environmental Baseline in Appendix C).

If beach recycling occurs in the future, or if new coastal defence structures are constructed, there will be a need to undertake regular water quality monitoring to assess the impacts (if any) of moving/placing material along the shoreline and/or altering the coastal defence arrangement. Bathing water quality monitoring is undertaken by the Environment Agency at several locations along the BMP area. This data is considered sufficient to provide a robust baseline for future Water Framework Directive (WFD) assessment that would be

needed as part of any potential future beach recycling that may occur. Post-implementation monitoring could be delivered to ensure the WFD objectives are not compromised by any future works along the frontage.

5. Action Plan

The BMP Action Plan sets out various activities that could be undertaken to help guide the preferred management approach for the BMP frontage, whilst also addressing specific issues raised in the baseline reporting and throughout the development of the BMP.

Table 5.1 Teignmouth BMP action plan.

Action Reference	Action Type	Action Summary	Action Activity	By Whom?	When by	Completed	Relevant Section in BMP
01	Management	Existing defences	A number of issues with the condition of the current defences were identified by the asset inspection completed for the BMP and in respect of public safety need to be addressed in the immediate future.	TDC / EA	Dec 25		Section 3.2
02	Management	Existing defences	The South West Water outfall acts as a groyne and is currently buried. Investigate potential inclusion of a new groyne at this location.	TDC			Appendix B and Appendix E
03	Management	Existing defences	There are currently no flaps on outfalls. Include in any future seawall maintenance, repair or improvements.	TDC			Appendix B and Appendix E
04	Management	Funding for preferred management approach	Work to advance the preferred management approach for Teignmouth, by identifying funding opportunities and preparing the appropriate business case. Working with the Environment Agency via the Teignmouth remedial works project where possible.	TDC / EA	With immediate effect		Section 2.7.2
05	Management	Develop a consultation plan and commence consultation with Natural England	Develop a consultation plan for implementation of the preferred management approach, and undertake consultation activities. As flagged in the Environmental Baseline, commence early engagement with Natural England. Draw on consultation responses received during Teignmouth remedial works project where possible.	TDC	Spring 2026		Appendix E

Teignmouth Beach Management Plan

Action Reference	Action Type	Action Summary	Action Activity	By Whom?	When by	Completed	Relevant Section in BMP
06	Management (further study)	Additional hydrodynamic modelling	Undertake further hydrodynamic modelling to investigate suitability of groynes with alternative dimensions (height, length, spacing) and use to inform the future management approach for the Teignmouth Open Coast frontage.	TDC/EA	Dec 2025		Appendix A
07	Management (further study)	Coastal processes understanding	There are a number of aspects identified in the Coastal Processes baseline which require further understanding, and could be used to better understand the shoreline dynamics in the BMP study area. Complete a new study specifically to address these knowledge gaps. This could also include analysis of the spit to determine overall change and if the spit is losing or gaining volume.	TDC	Dec 2026		Appendix A
08	Management	Beneficial used of dredge material	TDC to work with THC to progress recommendation to relocate current dredge disposal location. Begin by seeking funding to assist THC with beneficial use of dredge material.	TDC	Dec 2025		Section 2.3 Section 3.1.2
09	Management	Beneficial used of dredge material	Investigate suitable methods to place dredge material nearshore of and adjacent to Teignmouth Pier.	TDC	Spring 2026		Section 2.3 Section 3.1.2
10	Management	Beneficial used of dredge material	Complete any necessary testing of dredge material to test for suitability to place material nearshore.	TDC	Spring 2026		Section 2.3 Section 3.1.2
11	Management	Beneficial used of eroded cliff material	TDC to work with Network Rail/MMO to investigate and put into place potential beneficial use of eroded cliff material for the purpose of beach nourishment.	TDC	Spring 2026		Section 2.4.2

Teignmouth Beach Management Plan

Action Reference	Action Type	Action Summary	Action Activity	By Whom?	When by	Completed	Relevant Section in BMP
12	Management	Beneficial used of dredge material	Apply for a new Marine license for recycling of dredge (& eroded cliff material), noting that the Environmental Baseline (Appendix C, Section 3.2) states a new rather than a revision (or variation) would be required and outlines the reason for this. Undertake any necessary consultation as part of this process (as also outlined in that the Environmental Baseline (Appendix C, Section 3.2).	TDC	Spring 2026		Section 2.3 Section 3.1.2 Appendix C
13	Monitoring	Trigger levels for Shaldon	As recommended by the previous BMP, undertake new analysis using beach monitoring data to derive beach trigger levels for the beach at Shaldon.	TDC	Spring 2026		Section 3.4
14	Monitoring	Trigger level guidance note	Prepare a guidance note on the recommended trigger levels for defences and beach for use by for coastal managers at TDC when undertaking walk-over inspections or post-storm surveys and use to monitor defence condition and beach level against the trigger levels defined in the BMP.	TDC	Dec 26		Section 3.4
15	Monitoring	Update beach trigger levels	Following any new maintenance or new works to the seawall and groynes under the Teignmouth Remedial Works project or otherwise, the trigger levels within the BMP should be updated.	TDC/EA	Next one to two years		Section 3.4
16	Monitoring	Structure monitoring programme and reporting template.	Develop a programme for annual monitoring of the defences, and prepare a proforma/report template for future reporting.	TDC	Dec 2025		Section 4

Teignmouth Beach Management Plan

Action Reference	Action Type	Action Summary	Action Activity	By Whom?	When by	Completed	Relevant Section in BMP
17	Monitoring	First annual inspection and report	Commence and complete next defence inspection report, starting with Spring 2026. It is suggested that the inspection is completed after the winter so observations of any storm damage (outside of post-storm surveys) can be recorded	TDC	Spring 2026		Section 4.1
18	Monitoring	Beach monitoring programme and reporting template	Develop a programme for annual monitoring of the beaches, and prepare a proforma/report template for future reporting.		Dec 2025		Section 4.2
19	Monitoring	First annual inspection and report	Commence and complete first annual monitoring report using recommended data sources.	TDC	Spring 2026		Section 4.2.1
20	Monitoring	Increase survey frequency at Shaldon	There is limited beach profile data on the most exposed section of Shaldon seawall. This limits the assessment that can be made of overtopping and undermining risk of the wall. Survey data to be used alongside analysis of LiDAR data	TDC/SWRCMP	Dec 2025		Appendix B and Appendix E

6. References

Anthony D Bates partnership LLP (ADBP LLP), 2024. Teignmouth Harbour: Disposal of Dredged Material at Sprey Point. Water Framework Directive Assessment Report. Report prepared Anthony D Bates partnership LLP for Teignmouth harbour Commissioners, July 2024. Downloaded from: <https://marinelicensing.marinemanagement.org.uk/mmofox5/fox/live/>. Site accessed 15th September, 2025.

Binnies, 2024. Teignmouth Coastal Defences Engineering Assessment (Teignmouth Stability Assessment). Final report prepared for the Environment Agency, October 2024.

Binnies, 2023. Teignmouth Coastal Defences Engineering Assessment. Draft report prepared for the Environment Agency, April 2023

CH2M, 2014. Teignmouth & Shaldon Beach Management Plan. Prepared by CH2M for Teignbridge District Council, 2014.

CIRIA, 2010. Beach Management Manual (second addition). A CIRIA Report C685 RP787 © CIRIA 2010 ISBN: 978-0-86017-682-4-3. Published by CIRIA, Classic House, 174–180 Old Street, London, EC1V 9BP.

Environment Agency, 2024. FIG 3-Stage Review Form - Teignmouth SDS Remedial Works 15.01.24.

Environment Agency, 2023. Teignmouth Sea Defence Scheme Remedial Works. FCRM Pipeline Projects Internal Consultation.

Met Office, 2025. <https://climatedataportal.metoffice.gov.uk/datasets/TheMetOffice::sea-level-rise-projections-local-authority-v1/explore?location=50.543324%2C-3.507505%2C14.84> . Site last updated 27th March 2025 and accessed 8th August 2025.

Marine Management Organisation (MMO), 2025. Marine and Coastal Access Act 2009 (As Amended). Marine License Consent Decision Report. Project Description: Teignmouth Harbour Maintenance, Disposal of Dredged Material. Marine Management Application Reference: MLA/2024/00433. Decision Date: 14 March 2025. <https://marinelicensing.marinemanagement.org.uk/mmofox5/fox/live/>. Site accessed 15th September, 2025.

Appendices



Appendix A. Coastal Processes Baseline

Teignmouth Beach Management Plan

COASTAL PROCESSES BASELINE ASSESSMENT



Report provided by: Coastal Marine Applied Research,
University of Plymouth Enterprise Ltd.

Report provided for: Jacobs Ltd.

Date: 20/08/2024

Project code: 2005

Document code/version: 2005_d1v4

CMAR: Coastal Marine Applied Research

CMAR is a research-informed consultancy group based in the School of Biological and Marine Sciences at the University of Plymouth, south west UK, and contract our services through the university's wholly owned commercial subsidiary, University of Plymouth Enterprise Limited (UoPEL). We focus on coastal processes and marine physics, and aim to provide a first-class data collection, analysis, modelling, and synthesis service to help address important issues in the coastal and marine environment. We strive to understand and predict the behaviour of coastal, marine and estuarine systems to support the appropriate management of resources and activities in these environments. Our team consists of highly qualified coastal scientists and engineers, and our research on coastal dynamics is published in international, peer-reviewed journals.

All queries related to this document should be directed to:

CMAR, School of Biological and Marine Sciences, Reynolds Building, University of Plymouth,
Drake Circus, Plymouth, Devon PL4 8AA

Email: cmar@plymouth.ac.uk

Telephone: +44 1752 586177

Web: www.plymouth.ac.uk/cmar

Twitter: @pu_cmar



Document Information

Document permissions	Teignbridge District Council
Project number	2005
Project name	Teignmouth Beach Management Plan: Coastal Processes Baseline Assessment
Report date	August 2025
Report number	2005_d1v4
Client	Jacobs Engineering Group
Client representative	Emma Allan
Academic lead	Dr Mark Davidson
Project manager	Dr Arya Iwantoro, Dr Christopher Stokes
Consultant(s)	Dr Christopher Stokes, Miss Matea Zupicic, Dr Mark Davidson
Report Citation	Costal Marine Applied Research, 2024. Teignmouth Beach Management Plan: Coastal Processes Baseline Assessment, Report 2005_d1v4, University of Plymouth Enterprise Limited, 175 pp.

Document history

Date	Issue	Prepared	Approved	Authorised	notes
22/04/24	First Draft	MZ/CS	CS	MD	
07/05/24	Second Draft	MZ/CS	CS	MD	Includes Jacobs review
8/5/2025	Third Draft	AI/LB	AI	MD	Includes Jacobs review & additional XBeach modelling
20/08/25	Fourth Draft	LB	TP	MD	Includes Jacobs review

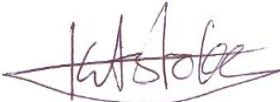
Document authorisation

Prepared	Approved	Authorised
		
Miss Matea Zupicic	Dr Christopher Stokes	Dr. Mark Davidson

ii To refer to the work within this report, please cite as:
 Coastal Marine Applied Research, 2025 Teignmouth Beach Management Plan: Coastal Processes Baseline Assessment. Report 2005_d1v4. University of Plymouth Enterprise Limited, 175 pp.



Miss Liane Brodie



Dr Arya Iwantoro

Teignmouth Beach Management Plan: Coastal Processes Baseline Assessment

Executive Summary

This coastal processes baseline assessment forms part of a new beach management plan (BMP) for Teignmouth, which is needed to guide flood, erosion and beach management activities along the frontage for the next 20-30 years.

Teignmouth's coastline is strongly influenced by the combined effects of both tidal and estuarine currents and storm waves arriving from both southerly and easterly approaches. These hydrodynamic processes drive the complex circulation of the ebb-tidal delta sandbars, as well as influencing littoral drift patterns and exchanges of sediment with the wider coastline to the south and north of the bounding headlands.

Storm waves arriving from the south or east direction drive opposing littoral drift directions on Teignmouth beach. However, storm waves arriving from the south or east direction drive, easterly waves occur less frequently, and have shorter wave periods and lower wave heights than waves arriving from the south. Based on 13.5 years of wave buoy data, easterly waves contribute only $\sim 1/3^{\text{rd}}$ of the total wave power, while southerly waves contribute $\sim 2/3^{\text{rd}}$. Sediment transport modelling undertaken for this study shows that littoral drift on Teignmouth Seafront beach is predicted to have a net south to north direction between Teignmouth Lighthouse and Holcombe Headland, with predicted net fluxes of up to 47,000 m³/year driven by the dominant southerly wave approach.

During a typical year, sediment transport driven by wave and tidal forcings is predicted to result in approximately, 24,000m³/year of sediment bypassing the northern headland (Holcombe Headland) and exiting the system, while around 31,000 m³/year enters Teignmouth from the southern headland (Ness Point). Ignoring the existing dredging activities, the model predicts that year-on-year there should be a modest net import of sediment from the wider coastline into the Teignmouth frontage of 7,000 m³/year, under typical conditions. This supports the notion that Teignmouth is not a closed sediment cell.

Between Teignmouth Lighthouse and Teignmouth Pier, chronic beach lowering of up to 3 m has occurred with up to 100 m³/m of intertidal sediment lost from 2007-2024, at an estimated rate of -5.88 m³/m/year. While injections of sediment from shore welding of the ebb-tidal sandbars may act to temporarily mitigate these losses every 2-4 years, the statistically significant negative trend over the last 15 years suggests that the sandbar circulation alone cannot be relied upon to maintain beach levels.

The most likely contributing factors to this observed beach lowering include a strong increase in the sediment flux north of Teignmouth Lighthouse (i.e. more sediment is being transported towards the north than is being replaced from the south), and a likely reversal of the transport direction between Teignmouth Lighthouse and Denn Spit, resulting in a divergence in net sediment flux direction (i.e. a sediment divide) at the location of the observed beach lowering. Other contributing factors include a 75% reduction in energetic wave conditions arriving from the east since the 1990s (which is likely to have reduced the return inputs of sediment from the east), and a predicted enhancement of sediment export to the wider coastline to the north of Holcombe Headland caused by the existing grab dredging regime.

The maximum licenced grab dredging quantity (45,000 tonnes/year) and existing grab and disposal locations, are predicted to change the net sediment budget at Teignmouth from a positive sediment budget (+7,000 m³/year) to a negative budget (-10,000 m³/year). Therefore, the existing grab dredging activities are predicted to lead to a year-on-year loss of sediment to the Teignmouth frontage (assuming the maximum licenced quantity is dredged) that would not be expected to occur naturally.

The reinstatement of timber groynes along Teignmouth Seafront shows that while groynes can promote sediment accumulation at their seaward ends, they also intensify circulatory currents that increase beach lowering near the seawall. Relocating the dredged sediment disposal site to the nearshore area of Teignmouth Pier provided only limited sediment transport back to the beach under typical wave conditions, suggesting that natural onshore delivery is insufficient. However, this sediment could potentially serve as a cost-effective nourishment source in erosion-prone areas along Teignmouth Beach.

The future evolution of Teignmouth's beaches over the next 100 years will depend, in part, on the net sediment balance. This is driven by inputs versus losses to alongshore and offshore regions. Alongshore losses depend on the occurrence of southerly versus easterly storms, with southerly storms, which tend to be stronger and more frequent, driving more material to the north than is returned southward under easterly storms. Additionally, the frequency of easterly storms has decreased over time, although it is presently unclear whether this trend will continue in future. Future beach behaviour will therefore depend on the occurrence and magnitude of southerly and easterly storms.

Even without changes in storminess, sea level rise is expected to lead to the progressive submergence of beaches, resulting a decrease in their width. This will be exacerbated by any existing beach lowering trends caused by alongshore sediment supply. Future beach evolution will be constrained by the presence of seawalls along the entire frontage, which are expected to exacerbate beach lowering, as well as other management activities such as the replacement or removal of the existing groyne field, and on the quantity and location of dredging activities. The future response may also depend upon

v To refer to the work within this report, please cite as:
Coastal Marine Applied Research, 2025 Teignmouth Beach Management Plan: Coastal Processes
Baseline Assessment. Report 2005_d1v4. University of Plymouth Enterprise Limited, 175 pp.

sediment sources from cliffs outside the study frontage as well as possible changes to the dynamics of the Teign estuary.

If existing sediment volume trends continue, the northern half of the Seafront Beach is expected to experience relatively modest beach lowering by 2120, maintaining a usable intertidal beach at most places in front of the trainline over the next century. Conversely, the southern half of the Seafront Beach is expected to experience accelerated beach lowering in future from coastal squeeze, exacerbated by existing negative trends in beach volume, and the beach there may be submerged throughout the tide by 2030 to 2050. At Denn Spit, the positive sediment trend indicates that seaward barrier growth could outpace landward migration over the next century.

Beach levels on Teignmouth Back Beach and Shaldon Beach are generally expected to stay within +/- 1 m of present-day levels, maintaining a usable intertidal beach over the next century. The exception to this is the seaward end of Shaldon Beach, which may drop below MLW by 2055-2080 if existing trends continue, meaning the intertidal beach there may become submerged.

Table of Contents

1	Introduction.....	1
1.1	Study rationale	1
1.2	Aims and objectives	1
1.3	Study area.....	2
1.4	Study approach.....	4
1.5	Modelling approach	4
2	Hydrodynamics	6
2.1	Tides and tidal currents	6
2.2	Fluvial input	6
2.3	Waves.....	7
2.3.1	Wave data	7
2.3.2	Analysis of wave climate	8
2.3.3	Balance of easterly vs southerly waves	12
2.3.4	Extreme Wave Conditions.....	13
2.3.5	Depth of Closure.....	15
2.4	Wave and tide driven circulation	16
2.4.1	Mean spring and neap tides.....	16
2.4.2	East and south storm waves with mean spring tide	16
3	Geomorphological setting.....	21
3.1	Sediment sources and sinks.....	24
3.2	Sediment grain size	25
3.3	Existing understanding of sediment transport pathways.....	26
4	Contemporary topographic changes.....	31
4.1	Teignmouth Seafront Beach.....	33
4.2	Teignmouth Back Beach.....	39
4.3	Shaldon Beach.....	39
5	Modelling sediment transport pathways	43

5.1	Tides only.....	43
5.2	Storm waves.....	45
5.3	Multiannual conditions	46
5.4	Sensitivity to modelled sediment size.....	48
5.4.1	Finer beach sediment (Estuary $D_{50} = 3$ mm, Beach $D_{50} = 0.3$ mm).....	48
5.4.2	Finer estuary sediment (Estuary $D_{50} = 1$ mm, Beach $D_{50} = 1$ mm).....	49
6	Influence of existing navigational dredging.....	51
6.1	Modelling approach	51
6.2	Lower estimated dredge quantity	52
6.3	Maximum licenced dredge quantity.....	52
7	Potential causes for observed beach lowering	55
7.1	Ebb-tidal delta circulation.....	55
7.2	Alongshore transport gradient.....	55
7.3	Alongshore transport divergence	56
7.4	Balance of easterly vs westerly wave conditions	58
7.5	Dredging activities	60
8	Future coastal evolution.....	61
8.1	Modelling future coastal squeeze.....	61
8.1.1	Teignmouth Seafront Beach	62
8.1.2	Point car park to Denn Spit.....	64
8.1.3	Teignmouth Back Beach.....	66
8.1.4	Shaldon Beach	67
8.2	Other considerations for future beach evolution.....	69
9	Hydro-morphodynamic Modelling for Engineering Options	71
9.1	Engineering scenarios	71
9.2	Model grid.....	72
9.3	Boundary conditions and model setups.....	72
9.4	Hydrodynamics	73

9.5	Implications of Engineering Options for Bed Level Dynamics.....	76
10	Denn Spit Dynamics	80
11	Conclusions.....	81
11.1	Summary of existing coastal processes.....	81
11.2	Evaluation of engineering options	82
11.3	Future evolution of Teignmouth’s beaches.....	83
11.4	Changes to existing understanding	84
11.5	Recommendations for further work	85
	References.....	87
Appendix A	Effects of seawalls on beaches.....	91
Appendix B	Statistical analysis of beach profile changes.....	96
Appendix C	Hydro-morphodynamic modelling using Delft3D-FM.....	108
C.1	Model domain	108
C.2	Model Grid.....	109
C.3	Forcing conditions.....	111
C.4	Sediment characteristics.....	115
C.5	Morphodynamic acceleration techniques.....	116
C.6	Calibration and validation	117
C.7	Model sensitivity analysis.....	124
C.8	Modelled engineered structures	128
C.9	Delft3D-FM assumptions and limitations	129
Appendix D	Future beach evolution modelling using ShoreTrans	130
D.1	ShoreTrans model description	130
D.2	ShoreTrans model setup.....	130
D.3	ShoreTrans results figures.....	135
Appendix E	Teignmouth Point Breakwater Modelling	147

1 Introduction

1.1 Study rationale

The Coastal Marine Applied Research (CMAR) team from the University of Plymouth have been commissioned to undertake a coastal processes baseline assessment for Teignmouth, on the south coast of Devon, UK. This coastal processes baseline assessment forms part of a new beach management plan (BMP) for Teignmouth, which is needed to guide flood, erosion and beach management activities along the frontage for the next 20-30 years. This project will work within the context of a longer term sustainable and integrated plan for managing these risks over the next 100 years that further develops the detail of how to implement the current Shoreline Management Plan, phase 2 (SMP2), policies and those emerging through the duration of the project from the SMP refresh process.

Within the study area (Section 1.3), the main receptors at risk from coastal flooding and erosion are the urbanised areas of Teignmouth and Shaldon, as well as the historic railway line that runs along part of the frontage. In addition to these, various other impact receptors have been identified in the brief for the current BMP, including:

- Teignmouth and Shaldon Coastal Defences, including groyne field(s) and foreshore beaches (Figure 3-1 and Figure 3-2)
- Teignmouth, Shaldon and Holcombe Bathing Beaches (Figure 4-1. and Figure 4-2.)
- Teignmouth, Shaldon and Holcombe beach amenity aspects and supporting businesses
- Teignmouth Port (Figure 1-1)
- Licensed dredge deposit site at Sprey Point (Figure 1-1)
- Teign Estuary fisheries
- Habitats i.e. Sabellaria reefs

1.2 Aims and objectives

There are various coastal flood and erosion risk management issues along the frontage to be considered by the overarching BMP project. The present coastal processes baseline assessment, which forms part of the BMP, aims to:

Review the existing coastal processes influencing coastal evolution along the project frontage, including assessment of any future coastal evolution and likely timing of when this may result in an increased flood or coastal erosion risk, and/or changes to beach levels.

To achieve this aim, the following objectives have been identified:

- Investigate sediment sources, inputs and circulation within the local system – Ness to Holcombe.

1 To refer to the work within this report, please cite as:
Coastal Marine Applied Research, 2025 Teignmouth Beach Management Plan: Coastal Processes Baseline Assessment. Report 2005_d1v4. University of Plymouth Enterprise Limited, 175 pp.

- Identify potential causes for observed beach lowering along Teignmouth seafront, Teignmouth Back Beach and Shaldon beaches, including current flood defence and harbour maintenance and management regime
- Appraise the influence/impact or otherwise of existing navigational dredging undertakings, especially on beach levels and recycling patterns.
- As part of the wider BMP project, feed into the process of identifying and justifying any beach management works required, for example groyne improvements, beach recharge etc.
- Produce a model or models to evidence above which can also be used to test future proposals in respect of defences, sediment patterns, maintenance (including dredging/disposal/recharge) operations and climatic change predictions

1.3 Study area

The project study extent is shown in Figure 1-1. This covers the length of coast from The Ness, Shaldon to the South; the Teign Estuary to Shaldon Bridge to the West, and Holcombe (aka, Parsons and Clark) headland to the North with the primary focus for the work being undertaken being along the Teignmouth coastal frontage (approximately 3.15 km between bounding headlands). The project area includes and boundaries a number of designations including:

- Designated Bathing Beaches (Shaldon, Teignmouth Holcombe, Teignmouth Town)
- Scheduled ancient wreck site
- Marine licensed dredging sites and associated marine disposal sites

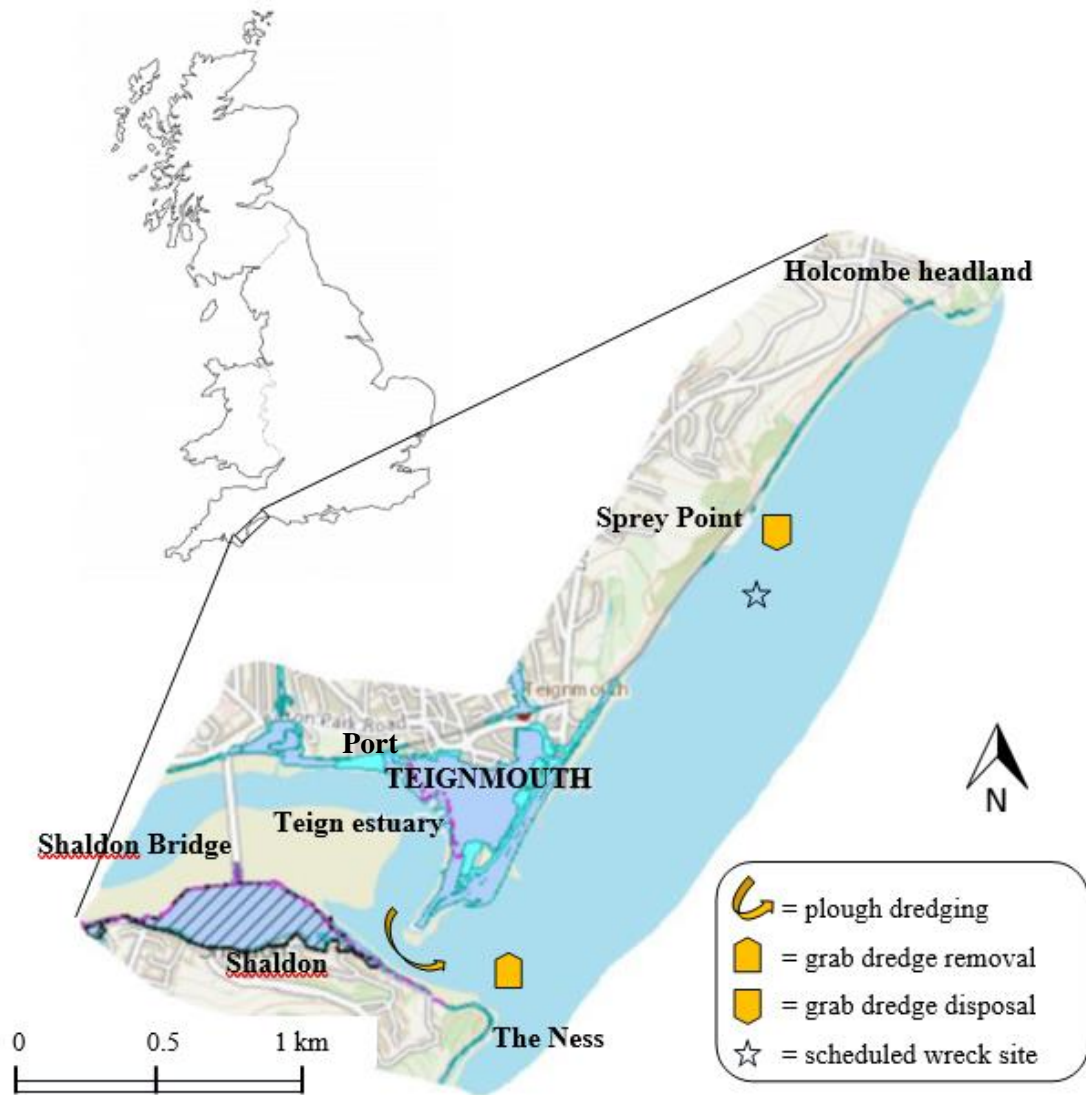

Figure 1-1. Sitemap showing the location of Teignmouth in the UK. The extents of the detailed map provide the study area of the present coastal processes baseline assessment. Purple and magenta areas indicate locations designated as at-risk from flooding (flood zone 3).

3 To refer to the work within this report, please cite as:
 Coastal Marine Applied Research, 2025 Teignmouth Beach Management Plan: Coastal Processes
 Baseline Assessment. Report 2005_d1v4. University of Plymouth Enterprise Limited, 175 pp.

1.4 Study approach

Teignmouth's coastal frontage and the Teign estuary, including Teignmouth Back Beach and Shaldon Beach, comprise a complex coastal-estuarine system with numerous coastal management challenges. As a result, the area has been heavily studied over recent decades in an effort to understand, model, and predict the current and future behaviour of this coastline. The present study will draw on the existing body of coastal processes knowledge of the area, as well as undertaking new analysis of wave data, topographic data, and numerical modelling of hydro- and morpho-dynamics along the various frontages. Finally, the study will look to make projections of possible future coastal evolution in the area, under a scenario of rising sea level.

These tools will be used to develop our understanding of the coastal processes at play along Teignmouth's beaches and will feed directly into the objectives identified above (Section 1.2). Finally, these tools will feed into an assessment of coastal management options at Teignmouth which may be required to mitigate against potential coastal flooding and erosion risk into the future.

1.5 Modelling approach

While there is a significant amount of prior understanding of beach dynamics at Teignmouth from numerous previous studies, as well as additional insights from observations of contemporary beach dynamics made in this study, modelling is required to inform us about the likely effect of coastal processes in the future, and what the effects of beach management schemes might be.

Beach evolution at Teignmouth is driven by a combination of sediment transport processes occurring over a range of timescales. These include cross-shore storm-recovery cycles (**short term**, days-months), gradients in alongshore sediment transport (**medium term**, months-years), and response to rising sea level and coastal squeeze (**long term**, years-centuries). Changing tidal prism and estuary flow rates are also likely to play a key role at Teignmouth into the future and could significantly affect morphological evolution along the inner and outer estuary. There is no single modelling tool currently available that can accurately simulate all of these processes over all relevant timescales, especially given the complexities of Teignmouth's sediment size distribution (Section 3.2), varying exposure to estuarine and coastal processes (Section 2), and the variety of coastal management practices already in place. In the present study, we use two separate models to achieve (1) an understanding of contemporary sediment fluxes and sediment budget, and (2) projections of possible future beach evolution under rising sea level:

- 1) **Delft3D (D-Flow, D-Waves, D-Morphology)**. This model simulates the hydro- and morphodynamic processes along the frontage, including wave, tide and estuary driven currents, and sediment transport in two dimensions inside and outside the estuary. The main objective of the Delft3D model is to quantify contemporary net sediment fluxes along

4 To refer to the work within this report, please cite as:
Coastal Marine Applied Research, 2025 Teignmouth Beach Management Plan: Coastal Processes Baseline Assessment. Report 2005_d1v4. University of Plymouth Enterprise Limited, 175 pp.

different portions of the frontage over short to medium timescales. This model will also be used to investigate the effects of implementing beach management options (not covered in the present report). Storm periods of 3.5 days were simulated to evaluate the effects of storm-threshold waves arriving from the south and east, and multi-annual periods covering 22 months were simulated to evaluate annual sediment fluxes.

- 2) **ShoreTrans.** This model simulates profile response to future rising sea level. Unlike the traditional Bruun Rule (Figure A-4), ShoreTrans can account for the presence of underlying bed rock and existing trends in sediment supply. ShoreTrans projections are made for a number of profiles along the frontage (Figure 4-1. and Figure 4-2.). The main objective of the ShoreTrans profile models is to predict future beach levels and coastal squeeze.

2 Hydrodynamics

2.1 Tides and tidal currents

Tides at Teignmouth are semi-diurnal and mesotidal, with spring and neap tidal ranges of 3.9 m and 1.6 m, respectively (Table). The estuary flows are ebb dominated, with flow speeds varying strongly at different points in the estuary and under different stages of the tide (ABPmer, 2012b). Spring and Neap tidal prism varies between $4.8 \times 10^6 \text{m}^3$ and $10 \times 10^6 \text{m}^3$, respectively, with the total annual volume of ebb tidal discharge through the estuary mouth estimated to be on the order of $5.2 \times 10^9 \text{m}^3$ (ABPmer, 2002). During spring tides, flood and ebb flow velocities in the estuary mouth can exceed 1.5 m/s and 3 m/s, respectively, with the strongest ebb tidal flows occurring as the tide drops below mid-tide, when a narrowing of the channel constricts the flows (Van Lancker et al., 2004).

As flows exit the estuary, they spread out and decrease in velocity. A complex flow circulation occurs over the ebb shoal delta with tidal flows across Spratt Sands reaching 1 m/s on spring tides (Hoekstra et al., 2004). Along the frontage between Teignmouth Beach and Holcombe headland, peak tidal currents are predicted to be on the order of 0.1 – 0.2 m/s under spring tides (ABPmer, 2012b; Stokes, Poate, Masselink, & Davidson, 2019; Van Lancker et al., 2004). In contrast to the estuary flows, which are maximised at mid ebb and mid flood stages of the tide, the strongest tidal flows in deeper water off the coast of Teignmouth are predicted to occur around low and high tide, with north to south flows at low tide and south to north flows at high tide. Under neap tides, all tidal velocities are greatly reduced (ABPmer, 2012b).

Table 2-1. Summary of tidal elevations and ranges at Teignmouth (Teignmouth Approaches) from UKHO Admiralty Tidal Charts).

Tidal Level/Range		Elevation (mODN)/ Range (m)
Mean High Water Springs	MHWS	1.95
Mean High Water Neaps	MHWN	0.95
Mean Sea Level	MSL	0.15
Mean Low Water Neaps	MLWN	-0.65
Mean Low Water Springs	MLWS	-1.95
Mean Spring Range	(MHWS-MLWS)	3.9
Mean Neap Range	(MHWN-MLWN)	1.6

2.2 Fluvial input

Riverine discharge into the Teign Estuary varies between $< 20 \text{m}^3/\text{s}$ in summer to $50\text{-}100 \text{m}^3/\text{s}$ in autumn and winter (ABPmer, 2012b). During periods of extreme riverine discharge, high flow rates and fluvial sedimentation are considered to be important to the morphodynamics of the estuary (ABPmer, 2012b;

6 To refer to the work within this report, please cite as:
Coastal Marine Applied Research, 2025 Teignmouth Beach Management Plan: Coastal Processes Baseline Assessment. Report 2005_d1v4. University of Plymouth Enterprise Limited, 175 pp.

Siegle, Huntley, & Davidson, 2002). However, the freshwater flows acting within the estuary are generally considered to be low in magnitude compared to the estuarine flows, and sensitivity modelling undertaken by (ABPmer, 2012b) revealed that freshwater discharges up to the Q90 value for the river Teign had a negligible influence on the current velocities in the lower estuary.

2.3 Waves

Outside the vicinity of the Teign estuary, waves are the primary driver of morphodynamic change along the open frontage of Teignmouth, from Teignmouth Pier to Holcombe Headland. Wave breaking at Teignmouth is typically characterised by spilling breakers during low tide, when waves interact with the dissipative lower beach profile, while at higher tides waves shoal over the low tide terrace and break as plunging breakers over the steeper upper beach profile (Van Lancker et al., 2004). Under high spring tides, the majority of the beach frontage is submerged and wave breaking therefore occurs on the upper beach profile as well as at the seawall.

On Teignmouth's Seafront Beach it has been observed that the longshore drift direction is generally aligned with the offshore wave direction (Van Lancker et al., 2004), and the occurrence of waves from different directions is therefore important to sediment fluxes along the open frontage (Section 2.3.1). The wave climate at Teignmouth is bi-directional, with a dominant southerly component originating from Atlantic swell and wind sea, and an east-south-easterly wind sea component originating in the English Channel (Stokes et al., 2019). Stokes et al. (2019). Stokes et al. (2019) concluded that while large waves can occur from either direction, easterly waves occur less frequently and are of shorter wave period than those from the south. Summation of the wave power flux over the period 1980-2019 showed that easterly waves contributed only 23% of the total alongshore oriented energy flux, compared to 77% contributed from waves arriving from the south, suggesting that waves drive net northwards littoral transport along the open frontage (Stokes et al., 2019).

Closer to the estuary, the shoreline becomes more sheltered from incident waves than along the open frontage. A previous modelling study demonstrated that Teignmouth's ebb shoal delta is quite effective at dissipating wave energy (ABPmer, 2012b). Storm threshold waves (nearshore $H_s = 2.4$ m $T_z = 6$ s) arriving under high spring tide with surge were simulated and it was shown that such waves are dissipated efficiently by the ebb shoal delta, regardless of their approach angle. As such, incident wave heights at the shore between Point Car Park and Teignmouth Spit were not greater than 0.5 m under such conditions, and were even less at Shaldon Beach and Teignmouth Back Beach (ABPmer, 2012b). Wave conditions therefore play a secondary role to tidally-driven estuary flows at these locations.

2.3.1 Wave data

In the following sections, wave data are analysed to provide an up-to-date assessment of the wave climate at Teignmouth. The wave climate was examined using wave buoy data from a nearshore

7 To refer to the work within this report, please cite as:
Coastal Marine Applied Research, 2025 Teignmouth Beach Management Plan: Coastal Processes Baseline Assessment. Report 2005_d1v4. University of Plymouth Enterprise Limited, 175 pp.

directional wave rider buoy, situated in approximately 14 m wave depth (relative to ODN) directly offshore of Dawlish Warren (50.5800° N, -3.4173° W). The buoy has been collecting directional spectral wave observations since December 2010. Data spanning December 2010 to February 2024, inclusive, are analysed here. These data represent actual measurements of the local wave climate but were collected ~6 km northeast of Teignmouth in a slightly more exposed region of the coast.

In addition to the wave buoy data from Dawlish, model hindcast predictions are available from the Copernicus Marine Environment Monitoring Service (CMEMS) AMM15 wave model (herein, AMM15). These data are generated by a Wave Watch III wave model and provide a re-analysis wave hindcast data set spanning from 1980 – present day, at 1.5 km spatial resolution around the UK. These data can be extracted closer to Teignmouth than the wave buoy data and provide useful information on the relative differences in wave conditions along the Teignmouth frontage. However, when AMM15 model data were compared to measurements from the Dawlish wave rider buoy it was found that peak wave heights, especially during extreme storms, were often significantly underestimated by the AMM15 model in this location (for example, Figure C-3). Therefore, wave conditions and especially extreme storm conditions (Section 2.3.4) for the present study were primarily analysed using the wave buoy data. The AMM15 data are used in Section C.3.1 to assess the relative variation in wave forcing conditions along the seaward Delft3D model boundary, to account for wave sheltering that occurs in the lee of Hope’s Nose headland.

2.3.2 Analysis of wave climate

From examination of the wave roses in Figure 2-1, the wave climate at Teignmouth is clearly bimodal in terms of wave direction and period, with a dominant component from the south-south-east (herein referred to as the southerly component), and a secondary component from the east-south-east (herein referred to as the easterly component). The longer peak wave periods ($T_p \geq 10$ s) evident in the southerly component confirm that those waves originate in the Atlantic Ocean where there is sufficiently long fetch to generate long period waves. Wave model data indicates that these waves refract in toward Teignmouth as they propagate up the English Channel, giving them a more southerly direction at the coast of Teignmouth compared to those measured at the Dawlish wave buoy. The waves from the east are comprised of shorter period ($T_p < 10$ s), locally generated waves, due to the reduced fetch in the English Channel.

From the histograms shown in Figure 2-2 – Figure 2-4, over 60% of all wave conditions arriving at Teignmouth have $H_s < 1.5$ m and $T_p = < 10$ s. The most common wave conditions arriving from either the south or the east have $H_s = < 0.5$ m and $T_p = < 6$ s (median $H_s = 0.4$ m). Figure 2-4 shows that while more than 17% of southerly wave conditions have peak periods greater than 10 s, less than 3% of easterly waves have periods greater than 10 s, indicating that well developed swell rarely arrives from

the east. Despite the lower occurrence and shorter periods of waves from the east compared to waves from the south, energetic conditions ($H_s > 2$ m) have occurred from both directions during the 13.5-year wave buoy monitoring period. Extreme wave heights from the south and east are explored further in Section 2.3.4

Monthly wave height statistics shown in Figure 2-5 show a clear seasonality in the wave height. December, January, and February experience the largest average and maximum wave heights, which usually decline to their minimum values in July. Median wave heights ($H_{s50\%}$) in summer are <0.25 m, while in winter are >0.5 m. The wave height exceeded only 1% of the time ($H_{s1\%}$) is >2 m in winter but is <1.5 m between May and September. Over the duration of the Dawlish wave buoy record (Dec 2010 – Feb 2014), the winter periods experiencing the largest $H_{s1\%}$ have occurred in the winters of 2013/14 and 2018, while the most energetic summer periods have occurred in the summers of 2012 and 2019 (Figure 2-6).

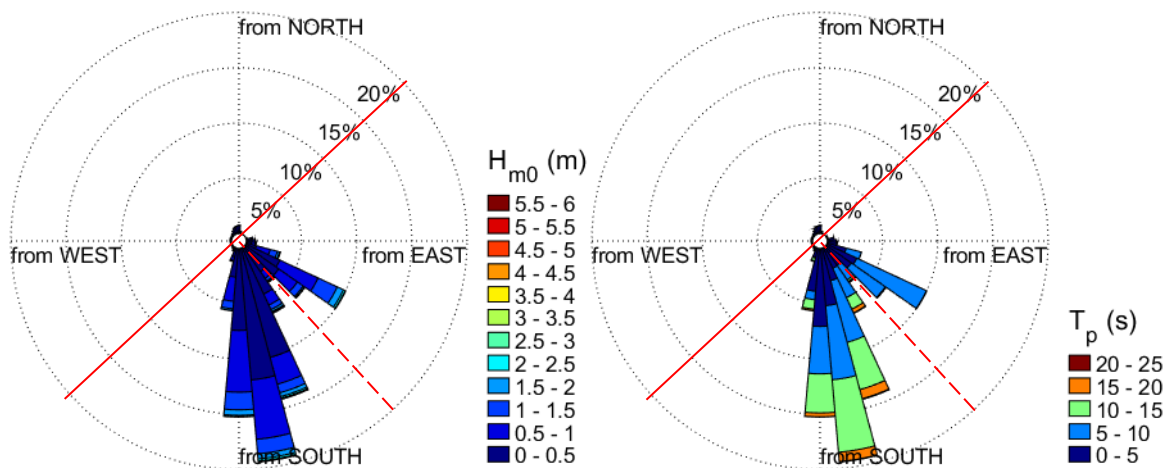

Figure 2-1 Directional wave roses of significant wave height (left panel) and peak wave period (right panel), measured by the Dawlish waverider buoy at the -14 mODN depth contour, between December 2010 and Feb 2024. The red solid and dashed lines indicate the angle of the shoreline and shore normal wave approach (145°), respectively.

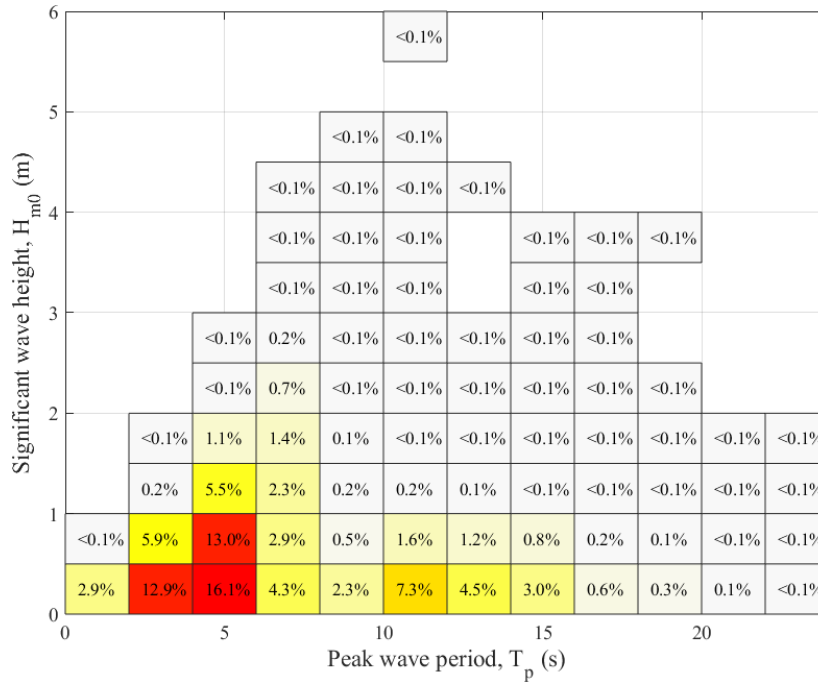

Figure 2-2 Percentage occurrence of significant wave heights (H_{m0}) and peak wave periods (T_p) measured by the Dawlish waverider buoy at the -14 mODN depth contour, between December 2010 and Feb 2024.

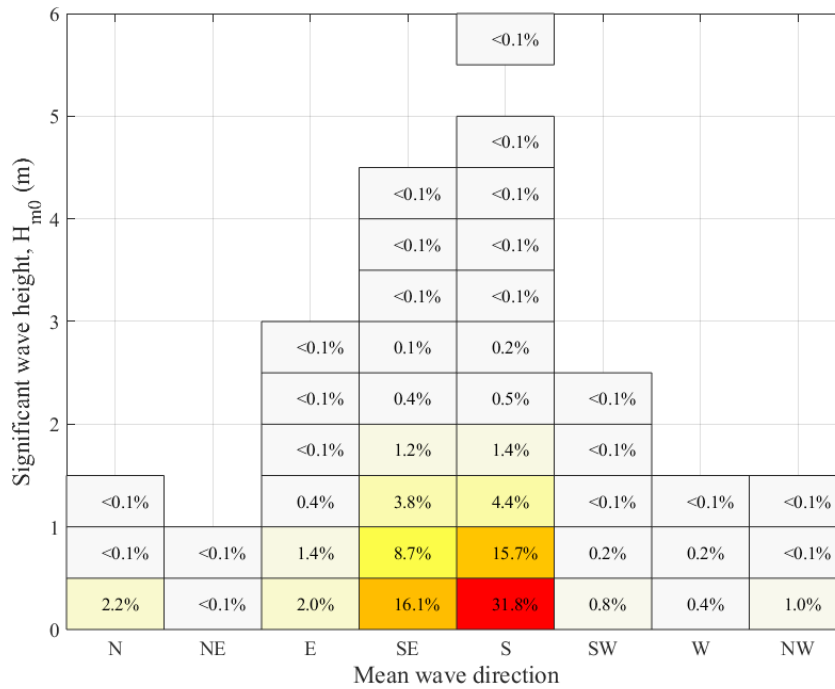

Figure 2-3 Percentage occurrence of significant wave heights (H_{m0}) and peak wave directions (D_p) measured by the Dawlish waverider buoy at the -14 mODN depth contour, between December 2010 and Feb 2024.

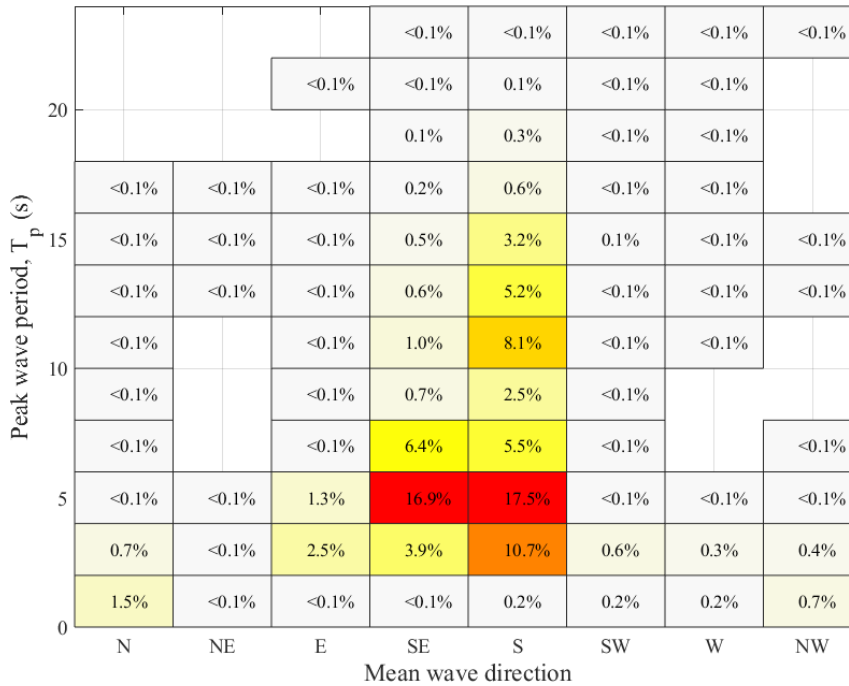

Figure 2-4 Percentage occurrence of peak wave periods (T_p) and peak wave directions (D_p) measured by the Dawlish waverider buoy at the -14 mODN depth contour, between December 2010 and Feb 2024.

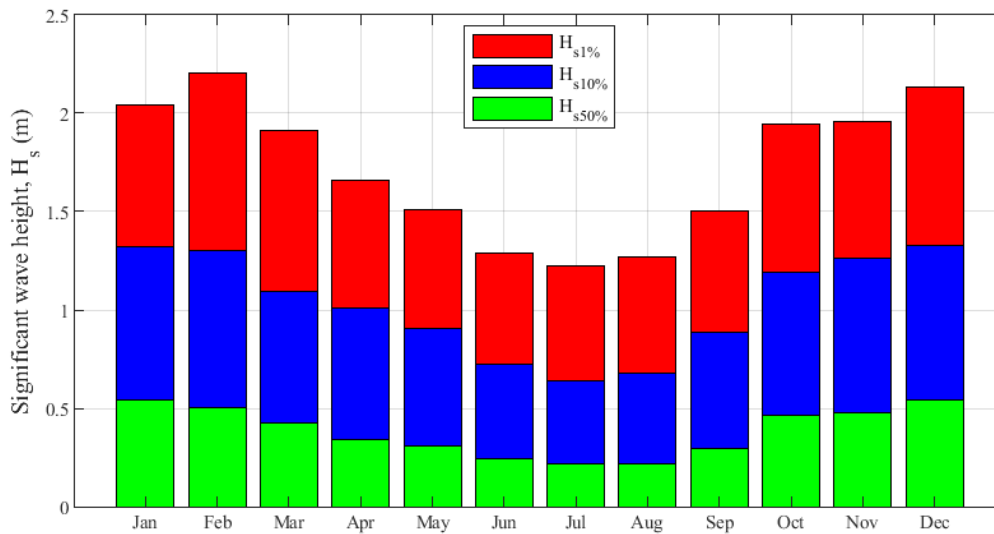

Figure 2-5 Monthly wave height statistics measured by the Dawlish waverider buoy at the -14 mODN depth contour, between December 2010 and Feb 2024. The top of each bar indicates the value of $H_{s50\%}$, $H_{s10\%}$ and $H_{s1\%}$ for each month, which are the significant wave heights exceeded only 50%, 10% and 1% of the time, respectively.

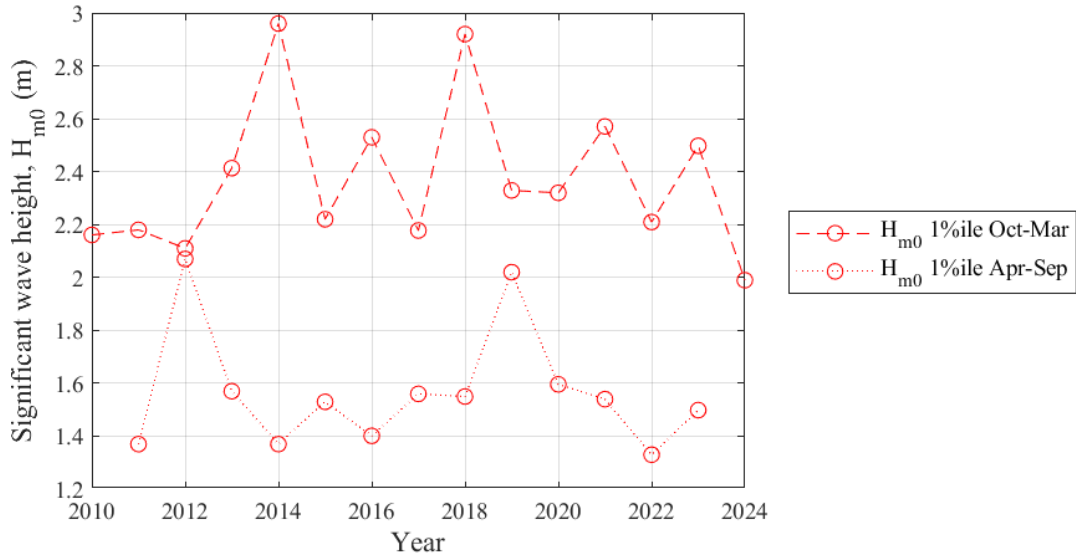

Figure 2-6 Annual wave height statistics measured by the Dawlish waverider buoy at the -14 mODN depth contour, between December 2010 and Feb 2024. Wave heights exceeded 1% of the time were computed for the winter and summer months of each year.

2.3.3 Balance of easterly vs southerly waves

The total wave power and alongshore orientated southerly and easterly components of the wave power are shown in Figure 2-7. The time series is obtained from the Dawlish wave buoy and shows a number of significant events during the 13-year monitoring period. Analysis reveals that 2/3rd (67%) of the total alongshore orientated wave power came from the south, and only 1/3rd (33%) came from the east during the wave buoy monitoring period from 2010-2024.

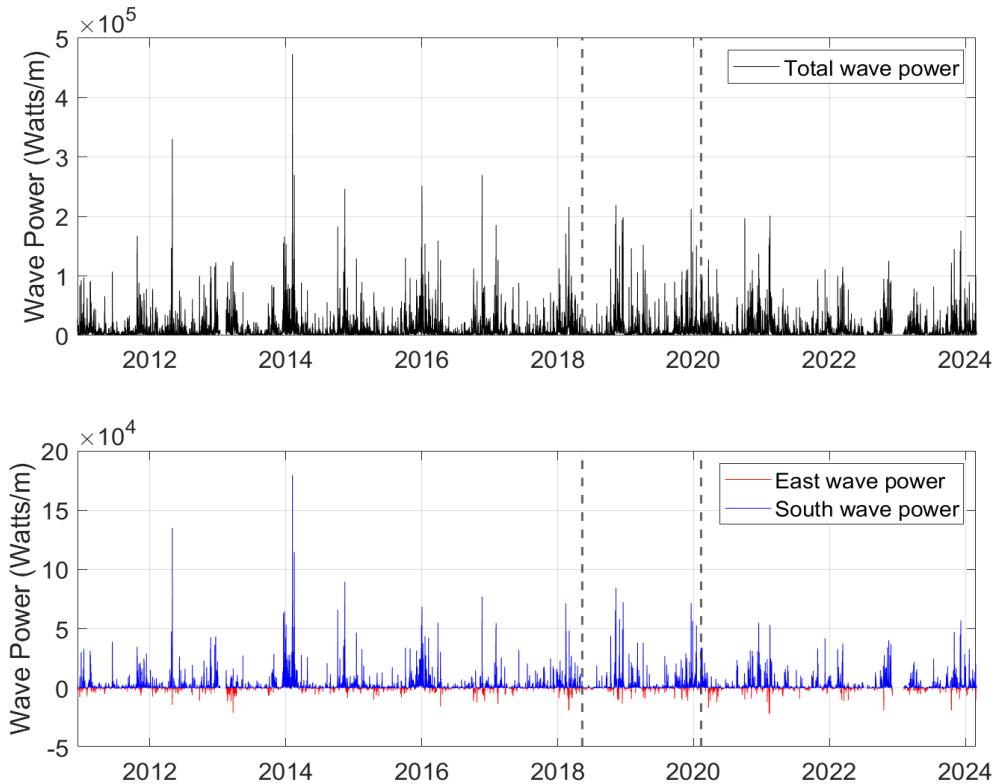

Figure 2-7.Total wave power (upper panel) and alongshore orientated wave power (lower panel) from the south (blue) and east (red) computed from Dawlish wave buoy data, measured at approximately -14 mODN depth contour. A direction of 145° from north was used to differentiate waves arriving from the two dominant approaches. The dashed lines indicate the multi-annual period simulated in Section 5.3.

2.3.4 Extreme Wave Conditions

An extreme value analysis (EVA) was performed on the data measured by the Dawlish waverider buoy at the 14 mODN depth contour, between December 2010 and Feb 2024. A peaks-over-threshold (POT) approach was used, whereby wave height measurements larger than a given threshold height were used to examine the distribution of extreme wave heights in the wave conditions time series. A Generalised Pareto Distribution (GPD) was fitted to these peak values, resulting in a statistical characterisation of the extreme tail of the wave height data from which wave heights of various return periods can be predicted. The GPD is now a well-established marginal distribution model for assessing extreme values of waves and water levels (Hamm, Mazas, Garcia, & Bailly, 2010; Jonathan & Ewans, 2013).

An assumption of this method is that the selected peaks are independent and therefore originate from independent storms (i.e. only one peak is gathered from each storm). To ensure this was the case, a minimum period of 2 days between storm peaks was required for each peak to be considered independent (Caires, 2011), which is at least twice the average duration of UK storm events (Dhoop & Mason, 2018). The threshold selected for the POT method was the 95th percentile of the data, which resulted in a good characterisation of the marginal distribution of wave height values (Figure 2-8). For

easterly waves a lower threshold (90th percentile) was used to ensure there were a sufficient number of data points for the analysis.

The length of the wave buoy record is 13.5 years, which is expected to provide statistically robust estimates for return periods up to at least twice the length of the wave record (Thompson, 2019), i.e. up to the 1-in-20 year RP estimate provided in Table . It is therefore acknowledged that the estimates of 1-in-50 and 1-in-100-year RP wave heights are less certain, given the length of available wave record.

The EVA analysis shows that wave conditions between the storm threshold (1-in-0.25 year) and 1-in-100-year return period (RP) range between 2.8 m and 5.8 m significant wave height at the Dawlish waverider buoy. This is in close agreement with previous EVA analysis by the South West Coastal Monitoring Programme (SWCMP; ‘Annual Wave Report, Dawlish’), which used 6 months less data and reports a range of 2.6-5.7 m for the same return periods. Here, a further EVA analysis was performed on the subset of southerly and easterly wave directions. Southerly storm waves are predicted to reach greater heights with 1-in-0.25 year to 1-in-100 year RP H_s ranging between 2.7 and 5.8 m, respectively, while easterly waves of the same return period are predicted to range between 2.1 and 4.4 m, respectively.

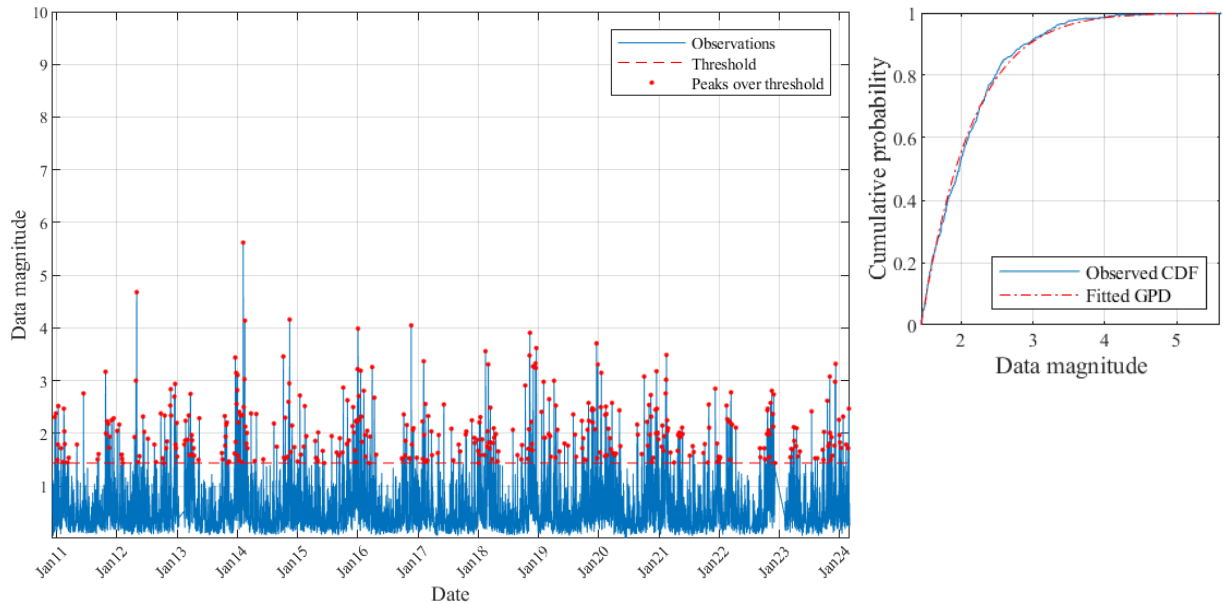

Figure 2-8 Extreme Value Analysis (EVA). Time series of significant wave height measured by the Dawlish waverider buoy at the -14 mODN depth contour, between December 2010 and Feb 2024 (left panel). Peak-Over-Threshold (POT) values are measured by the buoy are highlighted in red. Right panel illustrates Generalised Pareto distribution (GPD) fitted to the marginal wave height distribution.

Table 2-2. Results of Extreme Value Analysis (EVA) performed on the significant wave height measured by the Dawlish waverider buoy at the -14 mODN depth contour, between December 2010 and Feb 2024. Extreme significant wave heights are given for ‘southerly’ waves (145° – 270°), and ‘easterly’ waves (35° – 145°).

Return period	All waves H _{m0} (m)	Southerly waves H _{m0} (m)	Easterly waves H _{m0} (m)
1-in-0.25 year	2.77	2.70	2.07
1-in-1 year	3.58	3.57	2.74
1-in-2 year	3.96	3.96	3.04
1-in-5 year	4.43	4.45	3.42
1-in-10 year	4.76	4.80	3.68
1-in-20 year	5.08	5.13	3.93
1-in-50 year	5.48	5.53	4.23
1-in-100 year	5.76	5.81	4.44

2.3.5 Depth of Closure

The Depth of Closure (DoC) is a useful wave-driven parameter to describe the water depth beyond which changes in the beach profile are expected to approach zero. Multiple approaches are available to calculate DoC from wave data, and here we use three empirical equations (Birkemeier, 1985; Capobianco, Larson, Nicholls, & Kraus, 1997; Hallermeier, 1980) to calculate DoC at Teignmouth, taking the average of the three estimates as the representative value for the site. The three empirical equations used are:

$$DoC = 1.75H_e - \frac{57.9H_e^2}{gT_e^2} \text{ (Birkemeier, 1985),} \tag{1}$$

$$DoC = 2.28H_e - \frac{68.5H_e^2}{gT_e^2} \text{ (Hallermeier, 1980),} \tag{2}$$

$$DoC = kH_{12hr}^{0.67} \text{ (Capobianco et al., 1997),} \tag{3}$$

Where H_e and H_{12hr} are calculated from wave heights shoaled (or reverse shoaled) from the model node depth to 20 m depth. H_e is the ‘effective wave height’, or significant wave height that is only exceeded 12 hours per year (i.e., with a probability of yearly exceedance of 0.137%), T_e is the associated wave period, and g is the acceleration due to gravity (Birkemeier, 1985; Hallermeier, 1980; Nicholls, Birkemeier, & Hallermeier, 1996). H_{12hr} is the mean wave height over the 12-hour exceedance level, and k is a constant, here set to 3.4 following Nicholls et al. (Nicholls et al., 1996). The computed DoC represents a depth in meters below mean low water level.

The full 13.5 year wave record from the Dawlish waverider buoy was used to compute DoC For Teignmouth, which is considered to be of a suitable length for this purpose (Valiente, Masselink, Scott, Conley, & McCarroll, 2019), especially as it includes the extreme wave conditions that occurred in the winter of 2013/14 (Masselink et al., 2016). Data from this location is considered representative for Teignmouth, as inspection of the AMM15 wave model hindcast data shows relatively little difference in wave heights and periods between the location of the Dawlish wave buoy and the equivalent depth contour in the middle of the Teignmouth frontage.

From this analysis, **the computed DoC at Teignmouth is 4.26 m below Mean Low Water, which is equivalent to a depth contour of -5.4 mODN.**

2.4 Wave and tide driven circulation

2.4.1 Mean spring and neap tides

Tidal currents were simulated in the Delft3D-FM model (Appendix C). Figure 2-9 shows that under mean spring tides, current velocities reach up to 2 m/s in the estuary mouth and through Shaldon Bridge at the ebb tide peak (Figure 2-9, top right). During this period, the ebb tide flows rapidly exit the estuary mouth towards the southeast. During low tide (Figure 2-9, bottom left) The Salty becomes exposed and the flows become channel constrained in the estuary and ebb-tidal delta. During this phase, flow velocities are at their lowest, at 0.7 m/s. As the peak flood stage approaches, the tide fills the estuary (Figure 2-9, bottom right), with speeds reaching up to 1.4 m/s, ultimately leading to the complete filling of the estuary (Figure 2-9, top left).

In the mean neap tide simulation (not shown), the maximum current velocity reaches 0.8 m/s during the peak ebb stage of the tide in the deepest channel at the estuary mouth and through Shaldon Bridge within the estuary.

2.4.2 East and south storm waves with mean spring tide

Figure 2-10 illustrates wave and tidally driven currents during mean spring tides with storm-threshold waves arriving from the east. In the top right panel, the peak ebb stage of the tide shows the highest flow velocities overall, reaching 2 m/s in front of the estuary, which is comparable to the spring tide-only simulation. Under all stages of the tide, easterly storm-threshold waves drive southward wave-driven flows along the shore of approximately 0.7 m/s. Throughout the simulation eddies remain present, changing nearshore flow directions due to the interaction between waves and tidal currents.

Figure 2-11 depicts wave and tidally driven currents during mean spring tides with storm-threshold waves arriving from the south. In the top right panel, the peak ebb stage of the tide exhibits similar

behaviour in the estuary compared to the east storm and tide-only simulations. The highest flow velocities, reaching 2 m/s, occur in front of the estuary and are tidally driven. Under southerly waves, however, the estuary flows combine with wave driven flows away from the estuary mouth, driving strong northward currents just away from the shore that persist up to Sprey Point, with velocities of 0.5-0.8 m/s. Strong flows are also predicted at the shore to the south of Teignmouth estuary, bringing flow velocities of 0.5-0.8 m/s around Ness Point. During flooding and high tide stages, the combined action of wave-driven currents flowing northward and tidally-driven currents flowing southward towards the estuary create a divergence in the flow direction that occurs directly in front of Teignmouth Lighthouse (Figure 2-11, upper left and lower right panels).

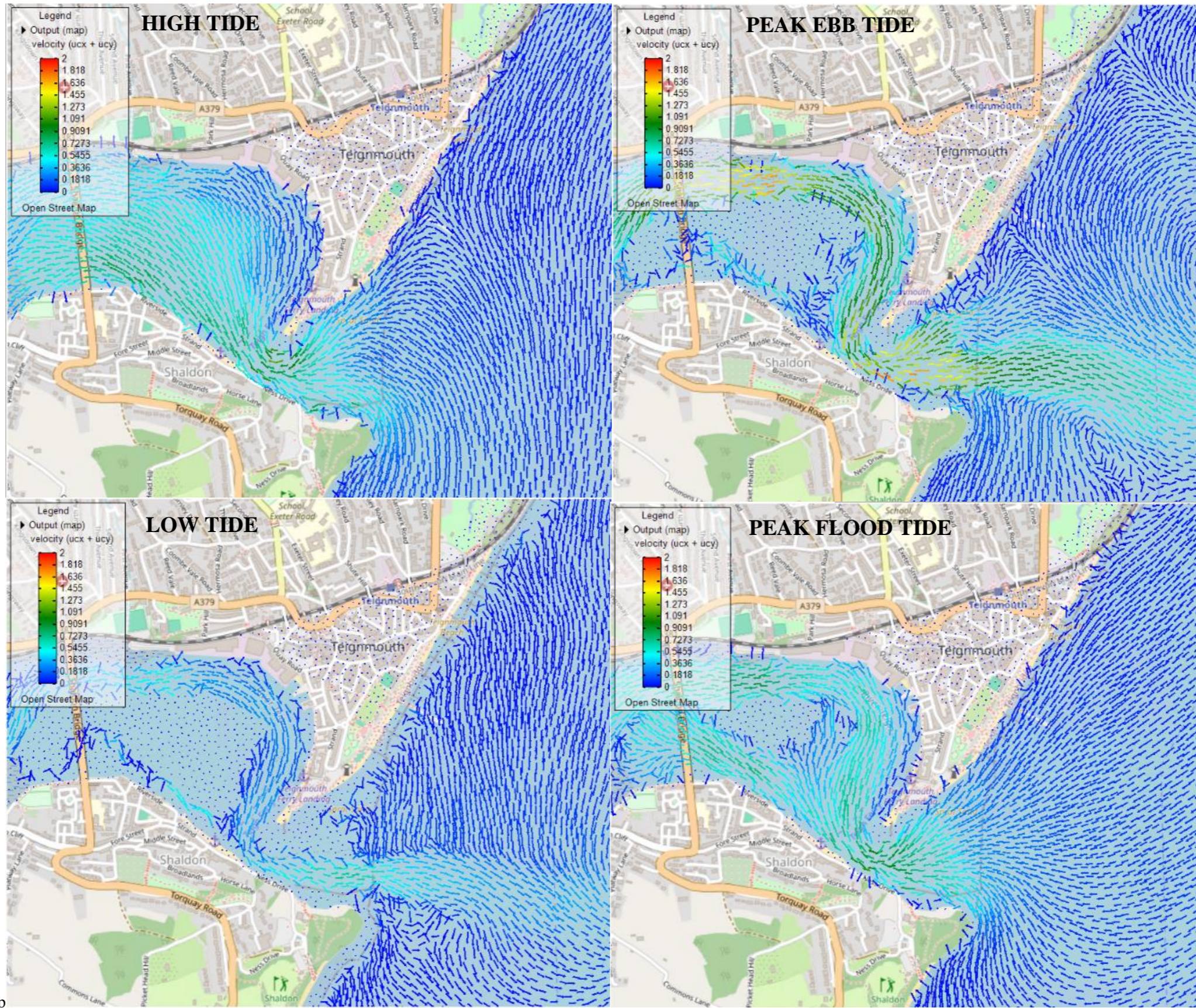

snipp

Figure 2-9. Peak flow velocities during high tide (top left), peak ebb (top right), low tide (bottom left), and peak flood (bottom right) stages of the tide. This simulation is forced with a mean spring tide and no waves.

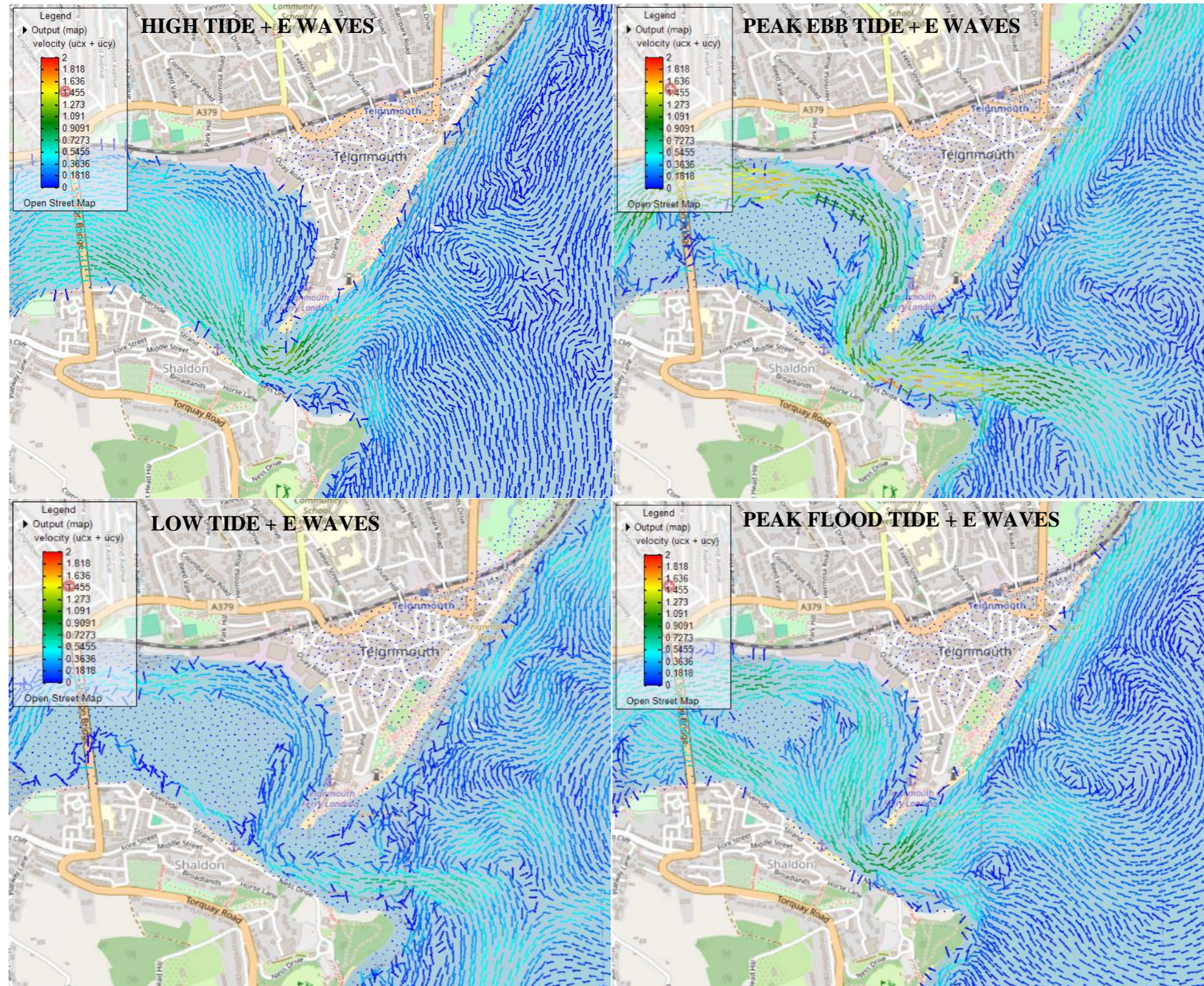

Figure 2-10. Peak flow velocities during high tide (top left), peak ebb (top right), low tide (bottom left), and peak flood (bottom right) stages of the tide. This simulation is forced with a mean spring tide and storm-threshold waves from the east.

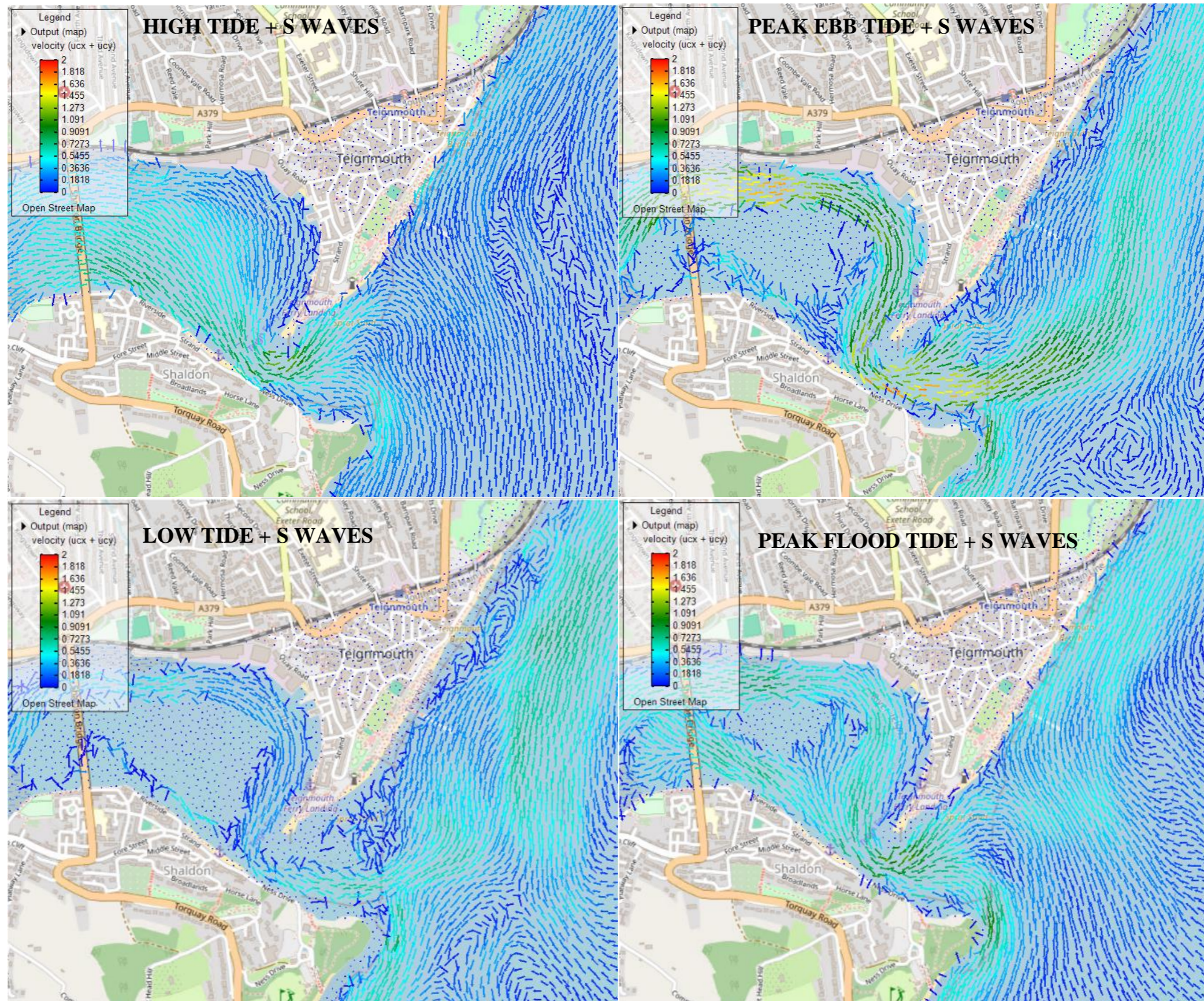

Figure 2-11. Peak flow velocities during high tide (top left), peak ebb (top right), low tide (bottom left), and peak flood (bottom right) stages of the tide. This simulation is forced with a mean spring tide and storm-threshold waves from the south.

3 Geomorphological setting

Teignmouth's beaches consist of the Seafront Beach, extending from Denn Spit to Holcombe headland to the north, Teignmouth Back Beach on the estuary side of Denn Spit, and Shaldon Beach, situated on the southern flank of the Teign estuary mouth (Figure 4-1. and Figure 4-2.). The geomorphology of the beaches is influenced either by estuarine flows (Back Beach and Shaldon Beach), mixed estuary and wave-driven flows (Denn Spit to Teignmouth Pier), or purely wave and tide driven flows (Teignmouth pier to Holcombe headland). Sediment is predominantly sand and gravel, but grain size is spatially variable around Teignmouth, varying by up to an order of magnitude (Section 3.2).

Teignmouth's coastline also features a number of engineered structures, which influence sedimentation and geomorphology in various ways (Figure 3-1 and Figure 3-2). The conceptual effects of such structures on beach geomorphology are reviewed in Appendix A. The structures include:

- Seawalls extending along the entire frontage of Teignmouth seafront beach, Teignmouth Back Beach and Shaldon Beach.
- A relic groyne field, consisting of approximately 20 wooden groynes on the seafront beach in relatively poor condition.
- A curved terminal groyne on Teignmouth spit, and additional terminal groynes on Teignmouth Back Beach.
- Teignmouth Pier, supported by several pilings embedded in the beach face.
- Sprey Point, a small, engineered headland which protrudes onto the beach ~35 m from the typical alignment of the seawall.

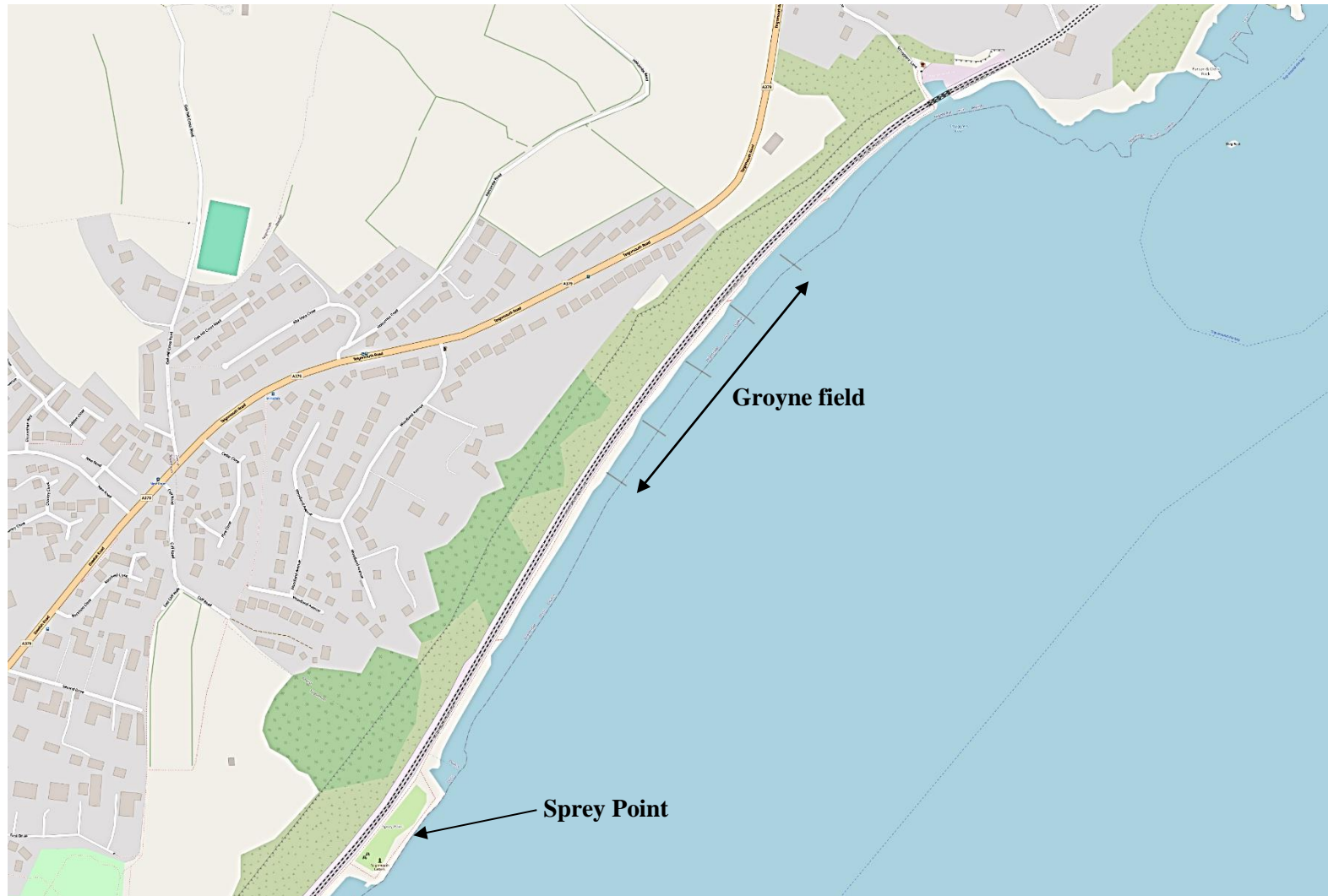

Figure 3-1. Teignmouth coastline with groyne field. Seawalls extending along the entire frontage of Teignmouth seafront beach, Teignmouth Back Beach and Shaldon Beach.



Figure 3-2. Teignmouth coastline featuring various engineered structures. Seawalls extending along the entire frontage of Teignmouth seafront beach, Teignmouth Back Beach and Shaldon Beach.

3.1 Sediment sources and sinks

The coastline surrounding Teignmouth is dominated by coastal cliffs fronted by narrow sandy beaches. The coastline to the south and north of Teignmouth features few hard sea defences and cliffs ranging from 15-125 m, which experience varying rates of cliff retreat. The 50 m high Ness Cliff at Shaldon is known to be particularly unstable, retreating at almost 1 m/year (ABPmer, 2012b), while the cliffs further south are believed to be more stable with retreat rates on the order of 0.1-0.2 m/year (SCOPAC, 2004). It is not clear how cliff retreat rates along the wider frontage may change in future, although Ashton, Walkden, and Dickson (2011) suggest that increased retreat is possible under accelerating sea level rise, which could potentially result in increased sediment availability along the coast in future.

The cliffs that back the northern portion of Teignmouth Beach are fronted by the railway line and seawall and have experienced multiple cliff failures of varying degrees of severity. Prior to the seawall being constructed in the 1840's, it is estimated that the cliffs along Teignmouth's frontage retreated at a rate of 0.5-2 m/year (Duvivier, 1998) and supplied between 40,000-160,000 m³/year of sediment to the local sediment budget (ABPmer, 2006). However, the construction of seawalls along the entire length of Teignmouth's frontage inhibits contemporary sediment supply from the local cliffs, aside from a nominal volume entering the beach across the seawall from occasional cliff failures.

It was previously thought that there was '*no evidence of any by-passing of Holcombe headland*' (New Forest District Council, 2017). However, the present modelling study (Section 5) suggests that significant volumes of sediment are able to bypass both Holcombe headland to the north and Ness Head headland to the south through the combined action of waves, tides, and estuary flow. This study therefore concludes that Teignmouth should not be considered a closed sediment cell (New Forest District Council, 2017), as significant exchanges of sediment are predicted with the wider coastline to the north and south when storm wave action and tidally induced flows mobilise sediment well beyond the theoretical DoC. The present study indicates that the frontage has a net positive sediment budget entering from the wider coastline, although a net negative budget is predicted when the maximum licenced dredge/disposal regime is simulated (Section 6).

Fluvial sediment entering the Teign estuary also contributes to the local sediment budget. The bedload flux of fluvial sediment has been estimated at 6,000 tonnes/year based on the catchment size and knowledge of other local river systems (Nunny, 1980), while suspended fluxes of fluvial sediment were estimated by ABPmer (2002) as 3,000-10,000 tonnes/year by applying mean suspended sediment concentrations to the mean river discharge rate. However, a portion of the fluvial sediment is stored within mudflats in the upper reaches of the estuary and the remainder is likely to be flushed through the estuary mouth during high river flows (New Forest District Council, 2017). However, it is thought that

fluvial sediment makes little contribution to the overall littoral sediment budget on the open coastline of Teignmouth's Seafront Beach (New Forest District Council, 2017).

The lower Estuary features a flood tidal delta known as The Salty, which is comprised of mixed sand and gravel believed to be of marine origin (Robinson, 1975). The main estuary channel flows around the northern side of The Salty, with a shallower channel flowing across the southern side. The latter is active above mid tide and may be the main conduit for marine sediment to enter The Salty during the flooding tide. It is believed that flood-tide estuary currents, in combination with wave stirring, are the mechanism for entrainment and transport of marine sediment into the estuary and onto The Salty (New Forest District Council, 2017). The Salty therefore acts as a local sink for marine sediment.

In the outer estuary, the ebb tidal delta features a complex of sandbars and channels, with the main estuary channel oriented towards the south-east direction. The sandbars are known to be highly dynamic and interact with the shore in the lee of the delta; they migrate around the ebb shoal delta over a multi-annual cycle described in Section 3.3. The ebb shoal delta represents both a source and sink of sediment (SCOPAC, 2004), as sediment is likely to be entrained in the delta system for several years (acting as a sediment sink), but intermittently feeds the intertidal beach near the location of Teignmouth Lighthouse when the nearshore delta sandbars weld to the shore (acting as a sediment source).

3.2 Sediment grain size

Intertidal beach sediments along Teignmouth's Seafront Beach were sampled in May 2018 as part of the South West Rail Resilience Programme (SWRRP; report PARTEISUR-002). Surface sediments were found to vary considerably along the frontage, ranging from medium sand to very coarse gravel (median sediment size, $D_{50} = 300 - 3000 \mu\text{m}$) characterised by an average D_{50} of $980 \mu\text{m}$ (coarse to very coarse sand). The spatial distribution of the major sediment classes along the frontage was mapped by the SWCMP in 2023 (Figure 3-3), indicating coarser sediments (gravel and sand) at Denn Spit, and distinct areas of sand and mixed sand gravel on the lower and upper beach face, respectively, from Teignmouth Pier northwards. Shaldon Beach, Teignmouth Back Beach, and parts of The Salty consist of gravel and sand. In the subtidal area beyond the Depth of Closure, grab samples conducted for the Coast3D project (Sutherland, 2001) show that the sediment is much finer and more spatially uniform than that of the beach, with D_{50} ranging between $111-173 \mu\text{m}$ (very fine to fine sand).

Within the ebb-shoal delta, considerably coarser material exists. Grab samples conducted for the Coast3D project (Sutherland, 2001) show that sediment size around the ebb-shoal delta ranges from $D_{50} = 2260-6840 \mu\text{m}$ (very coarse sand, gravel, and cobbles). Samples from the ebb-tidal sandbars (Section 3.3) reveal distinct lobes of deposition, with coarse gravel bedload observed in the lobes closest to the estuary mouth, then lobes showing settling of suspended sediment, and finally very fine sand that had been reworked in the lobes furthest offshore (Van Lancker et al., 2004). Within the narrowest area of

25 To refer to the work within this report, please cite as:
Coastal Marine Applied Research, 2025 Teignmouth Beach Management Plan: Coastal Processes Baseline Assessment. Report 2005_d1v3. University of Plymouth Enterprise Limited, 175 pp.

the estuary mouth, where peak estuary flows occur, bare bed rock has been observed (Van Lancker et al., 2004).

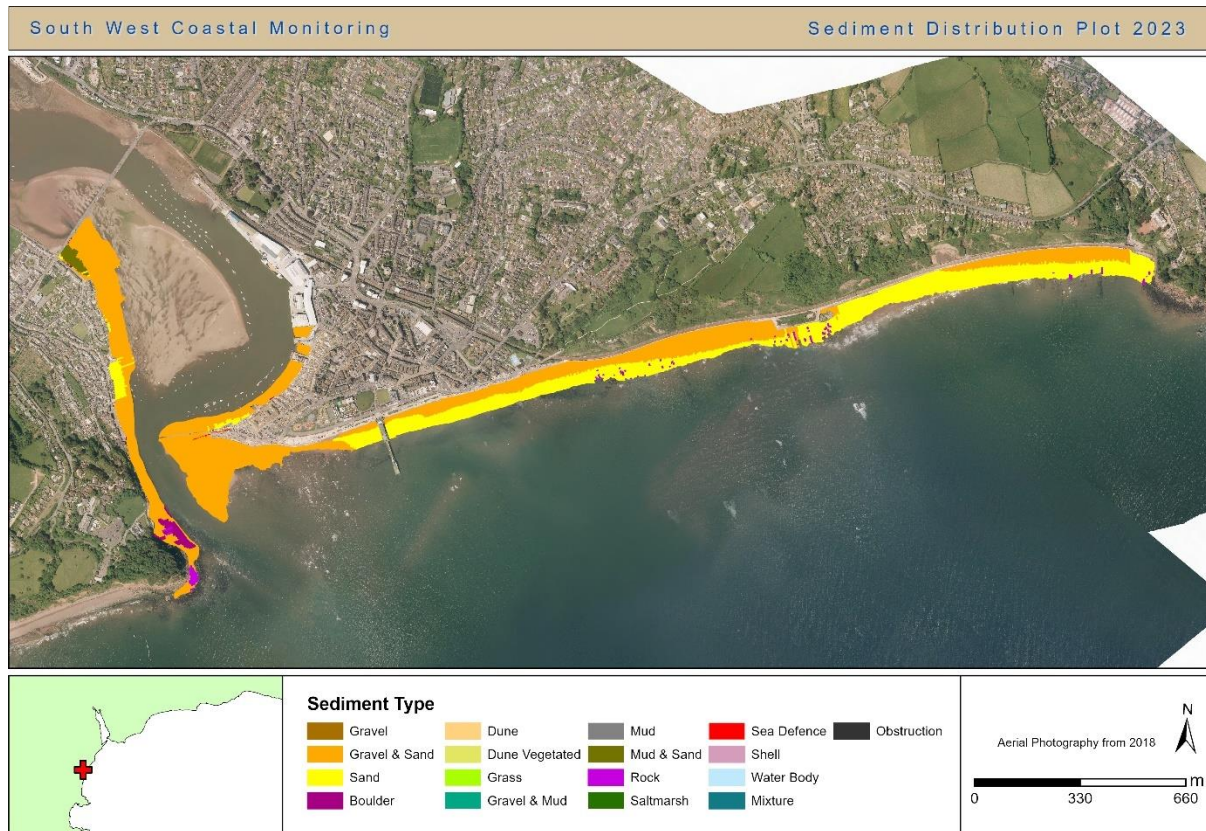

Figure 3-3. Sediment types on Teignmouth’s beaches. Courtesy of the South West Coastal Monitoring Programme, 2023.

3.3 Existing understanding of sediment transport pathways

The net littoral drift direction from Hope’s Nose to Holcombe is believed to be from south to north, forced by wave driven transport (New Forest District Council, 2017; Stokes et al., 2019). North of Sprey Point, Posford Duvivier (1998) estimated a net northward drift potential of 68,000 m³/year using hindcast wave conditions, while Posford Duvivier (1998); Stokes et al. (2019) estimated a net northward drift potential of 68,000 m³/year using hindcast wave conditions, while Stokes et al. (2019) predicted around 45,000 m³/year at the same location using an alongshore transport model forced with 10 years of time varying waves. The different estimated rates are likely to be due to differences in the wave forcing and sediment size applied. However, both studies agree that the net transport direction is from south to north, and the predicted rates are of a similar order of magnitude.

A reversal in the net northward littoral transport direction must occur at some location along the Teignmouth frontage, as Denn Spit could not have developed from the northern side of the Teign Estuary without north to south littoral transport occurring (New Forest District Council, 2017). This reversal has previously been believed to occur at Sprey Point, with net littoral drift from north to south

between Sprey Point and the Teign Estuary (Figure 3-4). This local sediment flux reversal has been attributed to currents from the Teign Estuary promoting flows at the shore towards the estuary during both ebbing and flooding phases of tide (New Forest District Council, 2017).

SCOPAC (New Forest District Council, 2017) found no clear evidence of sediment transport north of Holcombe and concluded that the headlands of Hope's Nose to the south and Holcombe to the north provide the boundaries for sediment transport. As such, this region was considered a near closed system with an independent sediment budget (New Forest District Council, 2017). The theoretical DoC at Teignmouth is 5.4 m below ODN (Section 2.3.5), which is approximately the depth at the toe of the Parson and Clark promontory at Holcombe headland. Therefore, under most wave conditions, waves would indeed not be expected to drive transport around Holcombe headland. However, it was recently shown that when tidal currents are factored in, the maximum depth of significant sediment transport (Depth of Transport, DoT) can exceed DoC (Valiente et al., 2019). For a coast like Teignmouth, where tidal currents at the headlands can reach 0.2 m/s (Section 2.1), DoT may be 10 m depth during waves of 3 m H_s (Valiente et al., 2019), which is likely to occur at least once a year at Teignmouth (Section 2.3.4). This assumes sediment of 0.3 mm, which is a reasonable value for subtidal sediments at Teignmouth (Section 3.2). The Teignmouth frontage is therefore likely to exchange sediment with the adjacent coastlines to the north and south during storm wave conditions.

The ebb tidal delta represents an important source and sink of sediment (Section 3.1) for the frontage south of Teignmouth Pier. A complex sediment transport pathway occurs, driven by a combination of strong ebb-dominant estuary currents and wave forcing (New Forest District Council, 2017). Seaward of Denn spit, a series of mobile sandbars undergo a cyclic pattern of movement around the ebb tidal delta. This has been studied extensively in the past, as early as the 1850's by Sprat (Sprat, 1856) and in more detail in recent decades (Hydraulics Research Station, 1970; Robinson, 1975; Siegle, Huntley, & Davidson, 2007). The sandbars move in an anti-clockwise manner (Figure 3-5) which involves three main stages of sediment movement (Robinson, 1975; Siegle et al., 2007):

- Stage 1: two sandbanks (Ness Pole and the offshore sandbank) grow at each side of the entrance channel. When the sandbanks grow enough to be exposed at low tide, they migrate in an onshore direction.
- Stage 2: an intermediate stage where the Ness Pole and offshore sandbank move closer to shore.
- Stage 3: an elongated, shore-normal orientated sandbank is attached to the pier and estuary mouth, which moves south feeding Sprat Sands.

The cycle of these sandbars is thought to be the main sediment transport pathway dominating the shoreline position in the area south of Teignmouth Pier (SCOPAC, 2004), and is especially relevant to this study given the observed trend of beach lowering adjacent to Teignmouth Lighthouse (Section 4).

27 To refer to the work within this report, please cite as:
Coastal Marine Applied Research, 2025 Teignmouth Beach Management Plan: Coastal Processes Baseline Assessment. Report 2005_d1v3. University of Plymouth Enterprise Limited, 175 pp.

For example, the Outer Pole can hold 7,000-9,000 m³ of sediment (Siegle et al., 2007) which, during stage 3, returns to the shore adjacent to Teignmouth Lighthouse (Figure 3-6), before the sand is moved southwards by tide and wave-driven littoral currents back towards the ebb-tidal delta. This is likely to be a key natural process for re-nourishing the shoreline between Teignmouth Lighthouse and Denn Spit (New Forest District Council, 2017), returning sediment to the shoreline that was previously stored within the ebb-tidal delta.

The sandbar dynamics are thought to be controlled by wave driven onshore accretion within the shoaling and breaking zones (e.g., moving sediment from Outer Pole – Inner Pole – Horseshoe Bank – shore welding) and offshore transport due to strong ebb-tidal currents in deeper water (e.g., moving sediment from Sprat Sands – Ness Pole – Outer Pole). During periods of low wave energy, the sandbars have been observed to extend seawards, while under high energy waves in autumn and winter the bars move shoreward (Siegle et al., 2007). Sprat (1856) noted a 3-7 year periodicity in the sandbar cycle, while Robinson (1975) observed stages 1-3 occurring over an average of 40 months, using 10 years of bathymetric measurements. Other studies have also observed secondary circulation patterns occurring over shorter timeframes (Hoekstra, Bell, van Santen, & Roode, 2001; Hoekstra et al., 2004). Over the long-term, an apparent decrease in the size and volume of the delta bars has been observed from photographic monitoring (Aird, 2009), suggesting the ebb-tidal delta may be gradually losing sediment volume.

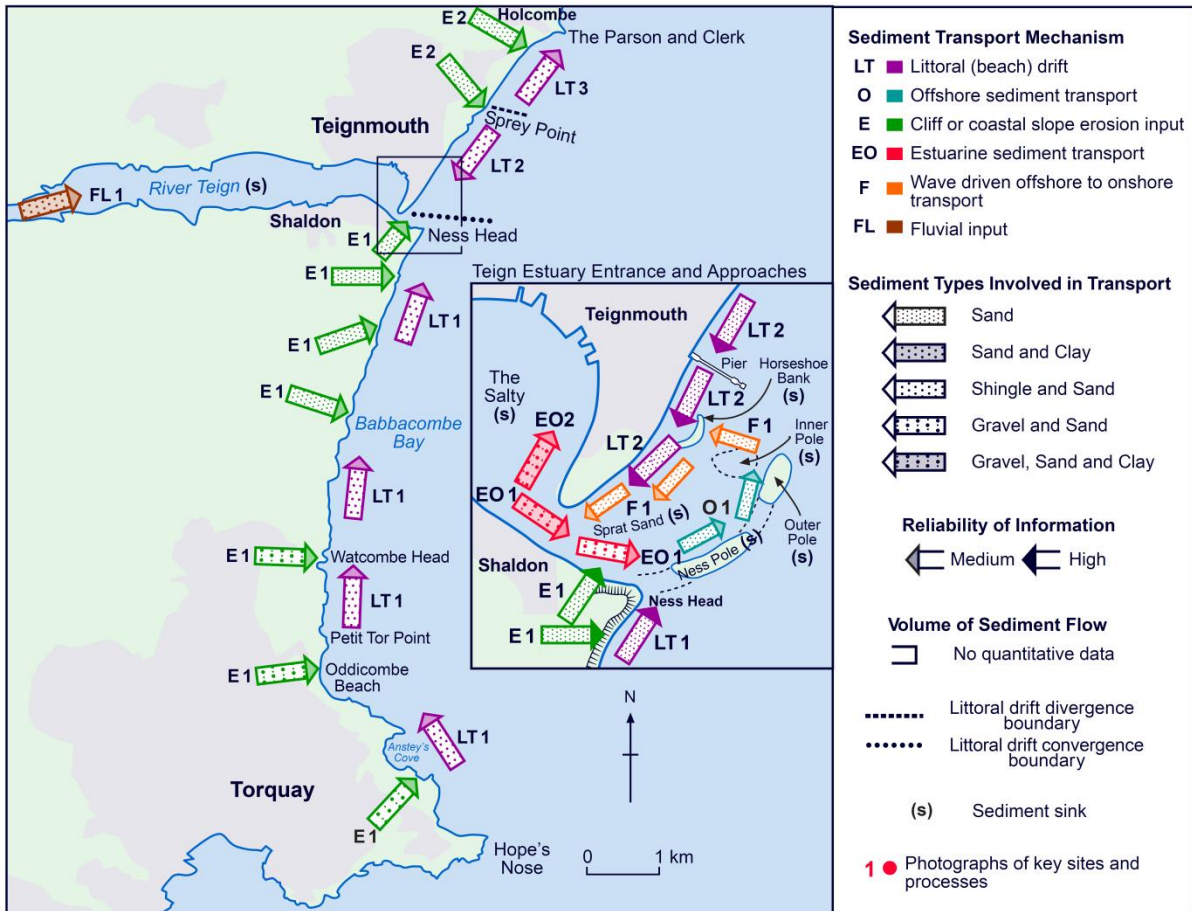

Figure 3-4. Holcombe to Hope's Nose (including the Teign Estuary) sediment transport, from SCOPAC (2004).

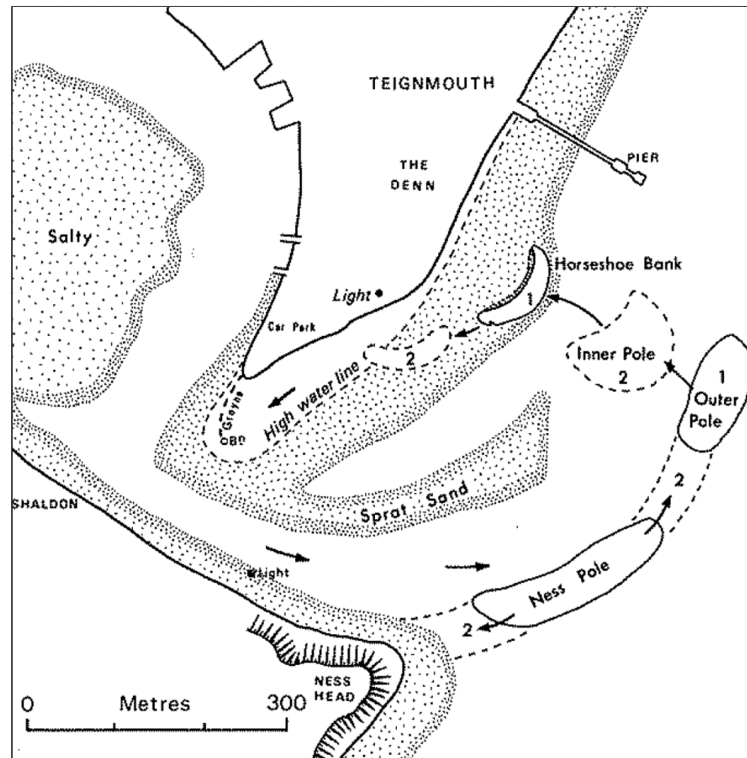

Figure 3-5. Conceptual description of sandbank circulation at Teignmouth's ebb-tidal delta, from Robinson (1975).



Figure 3-6. The Inner Pole of Teignmouth ebb-tidal delta during a shore-attached phase in 2001. As the Inner Pole migrates to the shore it delivers a significant supply of sand to the beach adjacent to Teignmouth Lighthouse (New Forest District Council, 2017).

4 Contemporary topographic changes

Beach topographic data spanning >15 years has been collected at Teignmouth by the SWCMP and was collated here to analyse morphological changes on Teignmouth's Seafront Beach, Back Beach and Shaldon Beach. Two methods were used to assess the morphological changes:

1. Comparison of two spatially continuous 'baseline' topographic data sets gathered in May 2007 and April 2022.
2. Analysis of bi-annual cross-sectional profiles spanning 2007 to 2023 (2011 to 2023 for Shaldon Beach).

Both methods utilise data collected via pole mounted RTK-GPS, with a nominal RMSE <0.03 m (Wiggins, Scott, Masselink, Russell, & McCarroll, 2019). Method 1 provides a spatially continuous picture of the net intertidal beach level changes. The difference in elevation measured over the two data sets indicates the net beach elevation changes over the 15-year epoch. Method 2 was used to analyse the intertidal variation and volumetric change over time for 15 profiles along Teignmouth's Seafront Beach (Figure 4-1.), as well as 3 profiles on the Back Beach and 3 profiles on Shaldon Beach (Figure 4-2.). More details on the quantification of profile volume and volumetric trends are provided in Appendix B.



Figure 4-1. Sitemap showing SWCMP interim profile locations for the Teignmouth Seafront Beach. All of the profiles shown were analysed as part of this coastal processes assessment.



Figure 4-2. Sitemap showing SWCMP interim profile locations for Teignmouth Back Beach and Shaldon Beach.

4.1 Teignmouth Seafront Beach

Since 2007, the north-eastern end of the Teignmouth seafront, from Sprey Point to Holcombe headland, has accreted, with 2022 intertidal beach levels generally >1 m higher than in 2007 (Figure 4-3). However, some localised sediment losses have also occurred immediately north of Sprey Point and by the trainline viaduct adjacent to Holcombe headland. Between Sprey Point and Teignmouth Pier a beach rotation signal is apparent from the LiDAR data. At least +3 m of sediment has accreted immediately south of Sprey Point since 2007, while extensive sediment losses of as much as -3 m are apparent south of Teignmouth Pier (Figure 4-5). This spatial pattern is evident for the 2007 to 2022 period and the updated 2007 to 2024 net change figure (Figure 4-6). Beach levels have been approximately stable at SWCMP profile 6b00198, which represents the pivot point of the beach rotation. Figure 4-7 illustrates the entire Teignmouth seafront showing coastal elevation changes from 2007 to 2024, with significant erosion occurring south of survey point 6b00198 and predominantly accretion observed along the northern sections of the coastline.

Inspection of intertidal profile volume over time (Figure 4-8) reveals that from 2007-2013 most profiles along Teignmouth Seafront were depleted in sediment volume compared to the initial volume measured in 2007. During this initial period of the monitoring data, there is little notable difference in intertidal beach response along the Seafront Beach, aside from some temporary sediment gains at certain profiles

(for example, 6b00161 and 6b00209). Following significant sediment redistribution during the unprecedented series of winter storms in the winter of 2013/14 (Masselink et al., 2016), the southern half of Teignmouth Seafront Beach (south of profile 6b00187) has been significantly more depleted, while the northern half of the beach has, in general, had significantly more sediment following 2013/14 than the initial volume in 2007.

This is unsurprising given that the winter storms in 2013/14 were highly energetic and all originated in the Atlantic Ocean, driving a net south to north littoral drift along Teignmouth Seafront. Notable easterly events have also occurred during the period under study, such as Storm Emma (aka, the ‘beast from the east’) in March 2018, which have driven a north to south littoral drift direction. However, the volume timeseries (Figure 4-8) indicates that the magnitude and frequency of easterly storms has not been sufficient to return the sediment from the northern part of the beach towards the south and re-balance the littoral sediment budget. The net effect of these beach volume changes is shown in Figure 4-9. This reveals a stark difference in intertidal volume between profiles fronting the promenade seawall in the south, which have lost as much as $-100 \text{ m}^3/\text{m}$ since 2007 (profile 6b00209), and profiles fronting the railway seawall in the north, which have gained $+30\text{--}130 \text{ m}^3/\text{m}$ since 2007 (profile 6b00157–6b00191).

Linear trends fitted to the volumetric timeseries reveal the average rate of change that has occurred along the Seafront Beach over the last 15 years (Appendix B). Statistically significant trends were found at most profiles along the Seafront Beach, indicating that the northern half of the beach fronting the railway line (profiles 6b00153–6b00191) has experienced intertidal sediment gains of approximately $+3 \text{ m}^3/\text{m}/\text{year}$ (alongshore range: $+1$ to $+9 \text{ m}^3/\text{m}/\text{year}$). Meanwhile, the southern half of the frontage fronting the promenade (profiles 6b00198–6b00212) has experienced intertidal sediment losses of approximately $-4 \text{ m}^3/\text{m}/\text{year}$ (range -9 to $-0.4 \text{ m}^3/\text{m}/\text{year}$).

The beach in the vicinity of the ebb-tidal delta (profiles 6b00209–6b00216) has shown dramatic variation in intertidal volume over the last 15 years (Figure 4-8), attributable to sudden gains and losses of sediment associated with the ness pole circulation (Section 3.3). Unlike the adjacent beach between Teignmouth Pier and Point Car Park, Denn Spit (profile 6b00212) is the only location in the southern half of the frontage that has exhibited a positive intertidal sediment trend, gaining $+4 \text{ m}^3/\text{m}/\text{year}$ on average since 2007. Overall, Denn Spit now has $\sim 20 \text{ m}^3/\text{m}$ more sediment than in 2007, albeit with significant gains and losses experienced over the last 15 years.

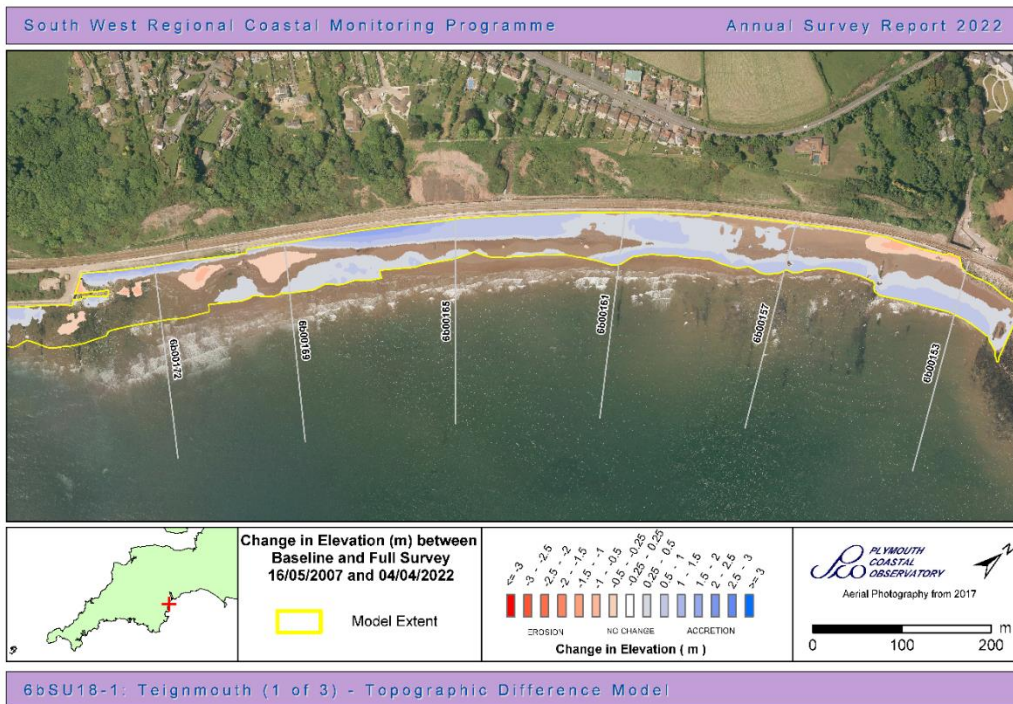

Figure 4-3. Net morphological response for the period 2007–2022 on Teignmouth Seafront Beach (North) from aerial LiDAR data. Red colour indicates net loss of material and blue colour indicates net gain of material.

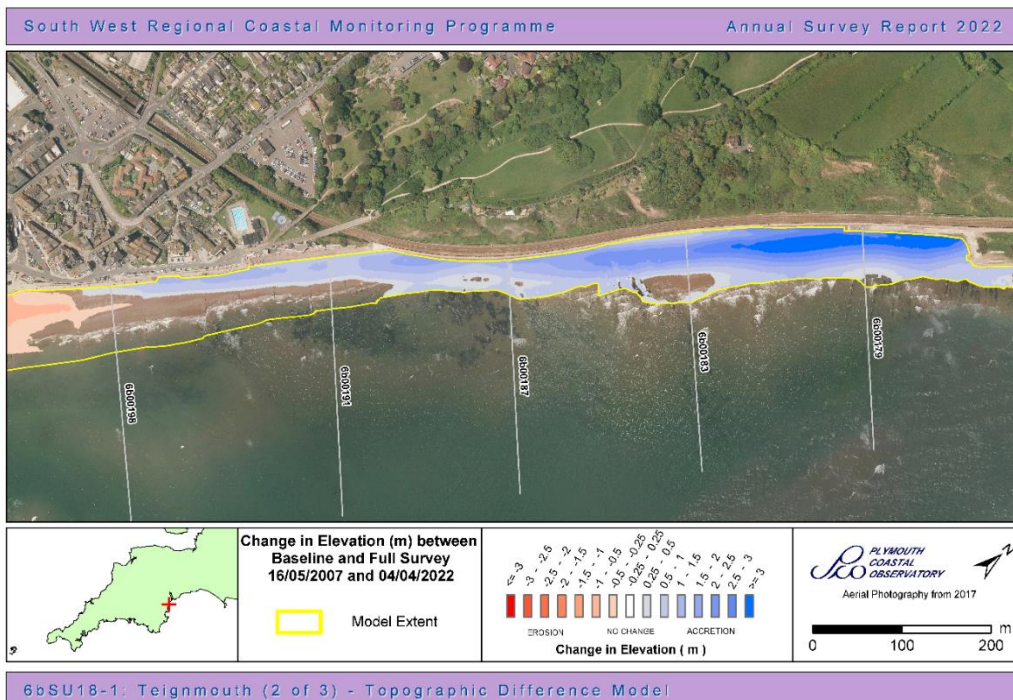

Figure 4-4. Net morphological response for the period 2007–2022 on Teignmouth Seafront Beach (Middle) from aerial LiDAR data. Red colour indicates net loss of material and blue colour indicates net gain of material.

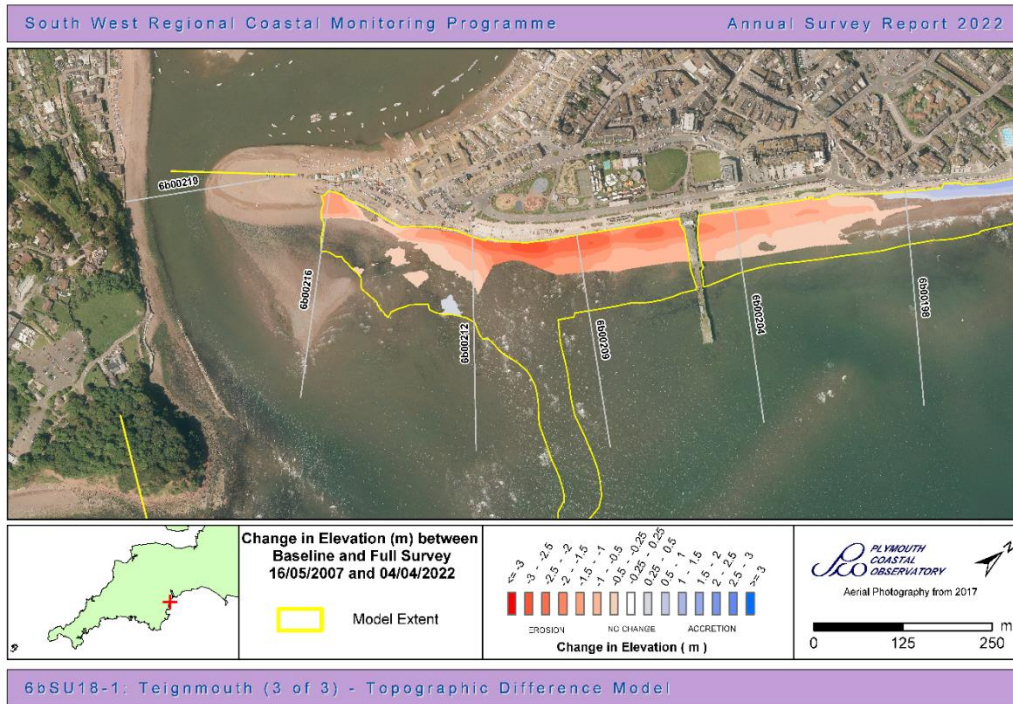

Figure 4-5. Net morphological response for the period 2007–2022 on Teignmouth Seafront Beach (South) from aerial LiDAR data. Red colour indicates net loss of material and blue colour indicates net gain of material.

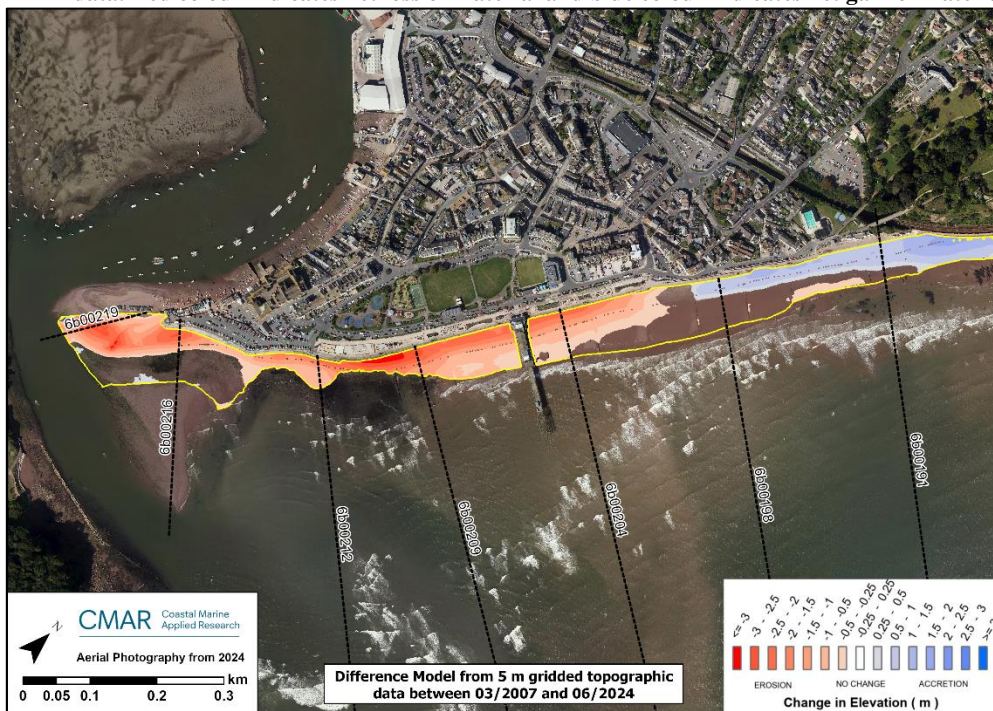

Figure 4-6. Net morphological response for the period 2007–2024 on Teignmouth Seafront Beach (South) from gridded topographic data. The figure has been produced to mirror the SWCM outputs presented in Figure 4-5. Red colour indicates net loss of material and blue colour indicates net gain of material.



Figure 4-7. Net morphological response for the period 2007–2024 across all of Teignmouth Seafront Beach (Full Extent) from gridded topographic data. Red colour indicates net loss of material and blue colour indicates net gain of material.

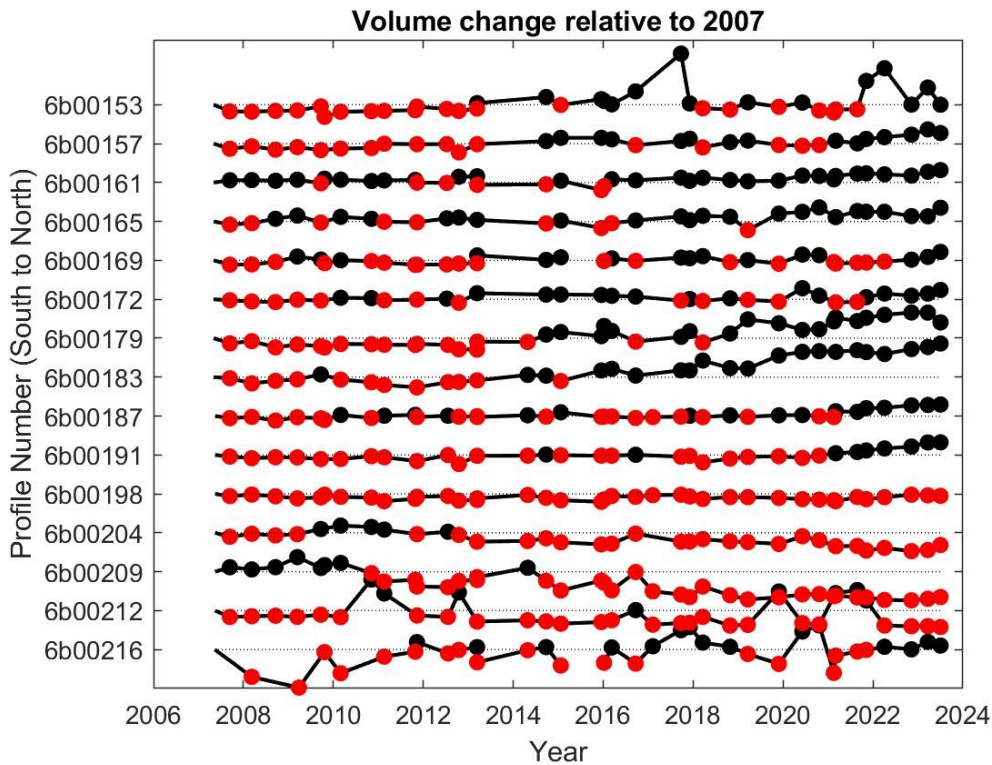

Figure 4-8. Intertidal profile volume through time, relative to the 2007 intertidal volume, for SWCMP interim profiles situated between Holcombe headland and Denn Spit. Red symbols show volumes lower than 2007 and black symbols show volumes greater than 2007. Episodes of bar welding from the delta can be seen as spikes in sediment volume on profiles 6b00209 – 6b00216.

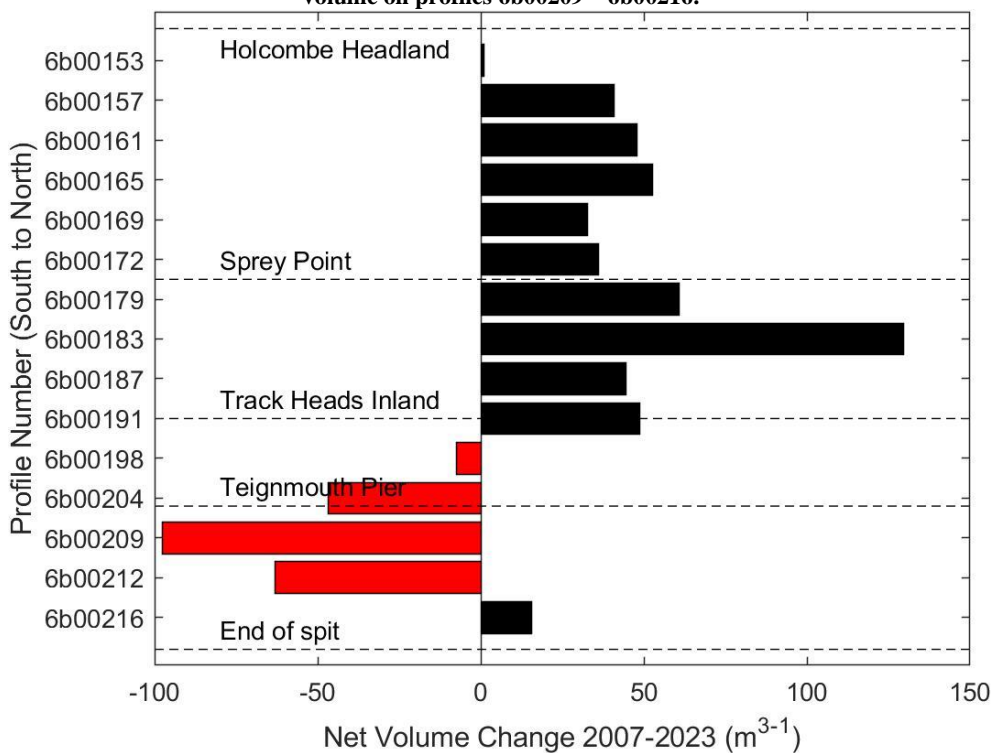

Figure 4-9. Net volume change for SWCMP interim profiles situated between Holcombe headland and Denn Spit between May 2007 and March 2023. Red bars indicate net loss of material, black bars show net gain.

4.2 Teignmouth Back Beach

Since 2007, Teignmouth Back Beach has remained relatively stable with little vertical change visible in the LiDAR difference plot shown in Figure 4-10. The exception to this is the estuary side of Denn Spit, which exhibits beach levels 1-1.5 m higher in the LiDAR data from 2022, compared to those measured in 2007.

The profile volume timeseries for Teignmouth Back Beach (Figure 4-11) indicates that the estuary side of Denn Spit increased in intertidal volume dramatically following the 2013/14 winter storms. This is presumably through storm induced overwash of sediment from the Seafront Beach, rather than alongshore transport of sediment from the northern end of the Back Beach, as there is not a comparable change in volume at the other Back Beach profiles during the 2013/14 winter. Overall, the back of Denn Spit has increased in volume by on average $+2.44 \text{ m}^3/\text{m}/\text{year}$ since 2007 (Appendix B).

In comparison, the intertidal volume of the Back Beach between Lower Point Car Park and Fish Quay has been much more stable over the last 15 years. Between Fish Quay and Morgans Quay (profile 6b00228) the beach has experienced a modest positive sediment supply trend over the last 15 years ($+0.43 \text{ m}^3/\text{m}/\text{year}$). Conversely, the beach between Morgans Quay and Lower Point Car Park (profile 6b00224) has seen a modest negative sediment supply trend ($-0.24 \text{ m}^3/\text{m}/\text{year}$).

The net effect of the beach volume changes on Teignmouth Back Beach is that the estuary side of Denn Spit now has nearly $40 \text{ m}^3/\text{m}$ more intertidal sediment than in 2007, while the beach between Lower Point Car Park and Morgans Quay has lost $\sim 4 \text{ m}^3/\text{m}$, and the beach between Morgans Quay and Fish Quay has gained $\sim 7 \text{ m}^3/\text{m}$.

4.3 Shaldon Beach

Between 2011 and 2022, Shaldon Beach exhibits a beach rotation signal, with a significant increase in beach elevation at the western end of Shaldon Beach on the inside of the estuary, and a significant decrease in elevation at the eastern end just outside the estuary mouth (Figure 4-10). Beach levels have increased and decreased at these two ends of Shaldon Beach, respectively, by 1-1.5 m over the LiDAR epoch.

The profile volume timeseries for Shaldon Beach (Figure 4-13) indicates that intertidal volume has been most volatile at the north-western end of Shaldon Beach near Clipper Quay. This end of the beach has also seen the greatest overall volume gains since monitoring data started being collected at Shaldon in 2011. The western side of Shaldon Beach (profiles 6b00254 and 6b00256) has experienced a trend of increasing intertidal volume since 2011 ($+0.5-1 \text{ m}^3/\text{m}/\text{year}$), while the middle of Shaldon Beach (profile

6b00258 adjacent to the estuary mouth) has seen a trend of decreasing intertidal volume since 2011 (-0.7 m³/m/year).

The net effect of the beach volume changes on Shaldon Beach (Figure 4-14) is that the western end of Shaldon Beach now has +8-9 m³/m more intertidal sediment than at the start of the monitoring period in 2011, while the middle of Shaldon Beach adjacent to the estuary mouth has lost more than -4 m³/m of intertidal sediment since 2011.

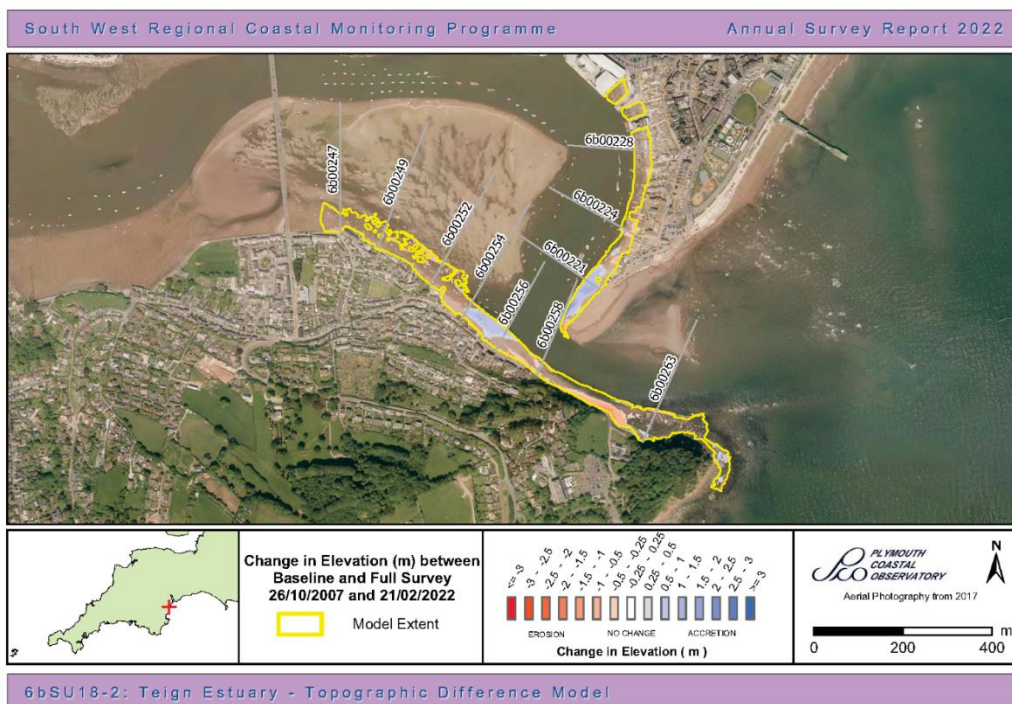

Figure 4-10. Net morphological response for the period 2007–2022 on Teignmouth Back Beach and Shaldon Beach from aerial LiDAR data. Red colour indicates net loss of material and blue colour indicates net gain of material.

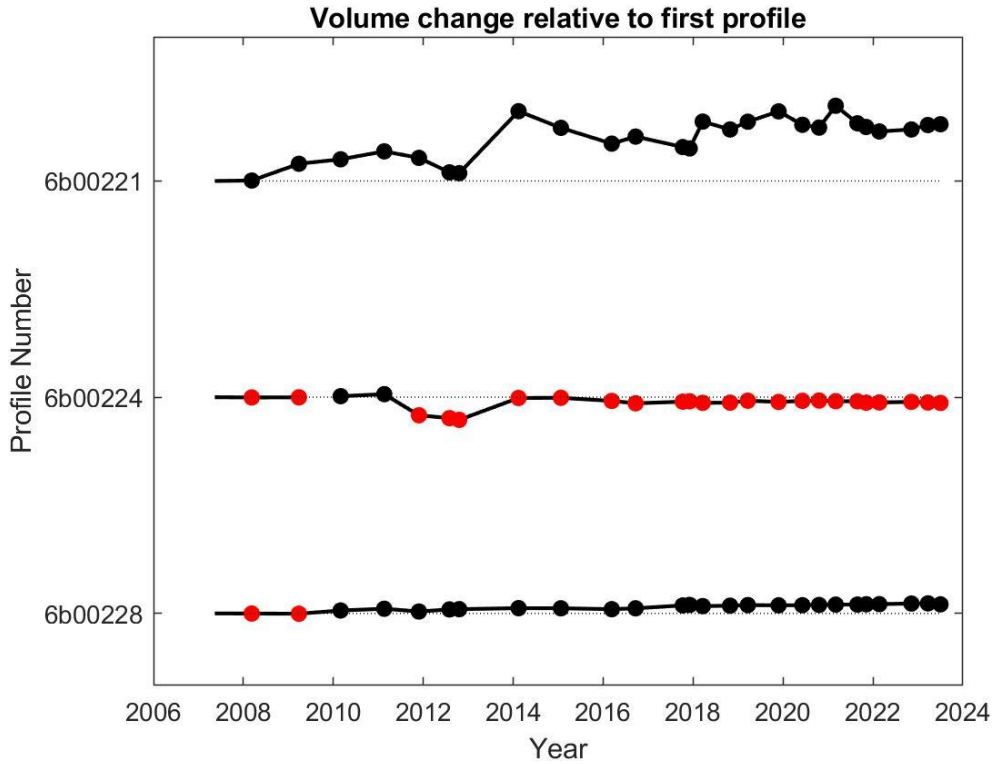

Figure 4-11. Intertidal profile volume through time, relative to the 2007 intertidal volume for profiles on Teignmouth Back Beach. Red symbols show volumes lower than 2007 and black symbols show volumes greater than 2007.

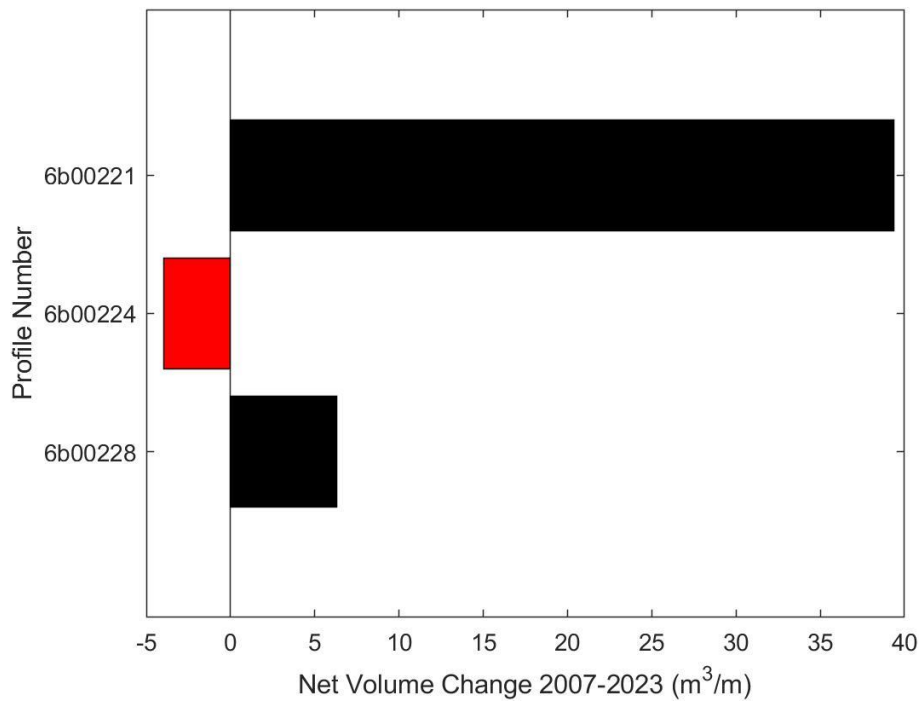

Figure 4-12. Net volume change for profiles on Teignmouth Back Beach between May 2007 and July 2023. Red bars indicate net loss of material, black bars show net gain.

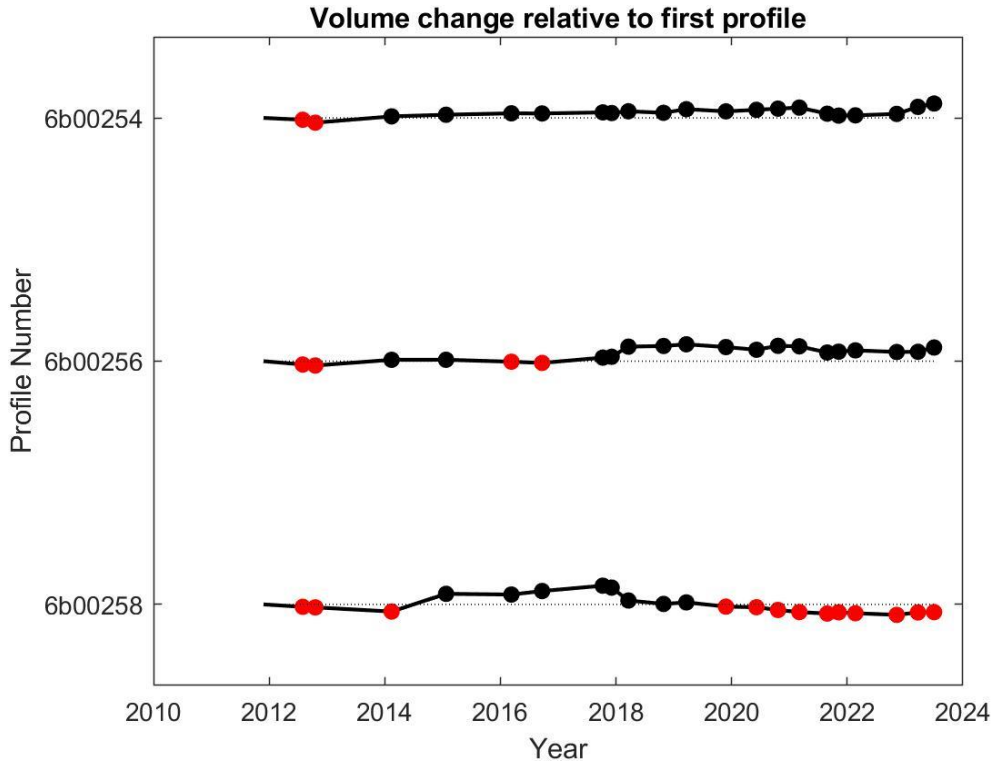

Figure 4-13. Intertidal profile volume through time, relative to the 2011 intertidal volume for profiles on Shaldon Beach. Red symbols show volumes lower than 2011 and black symbols show volumes greater than 2011.

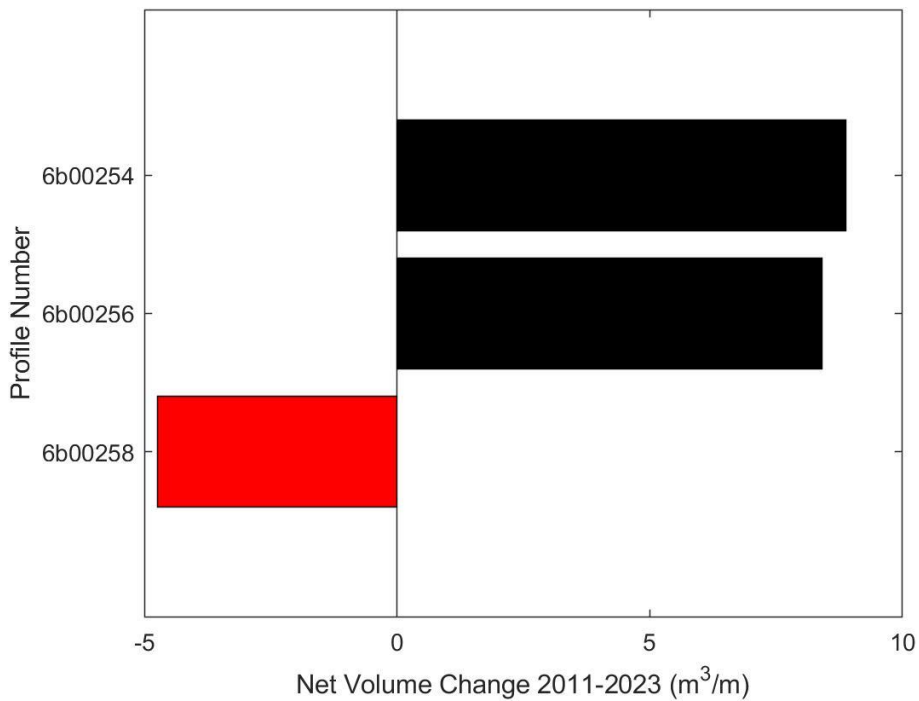

Figure 4-14. Net volume change for profiles on the Shaldon Beach between November 2011 and July 2023. Red bars indicate net loss of material, black bars show net gain.

5 Modelling sediment transport pathways

To gain further understanding of sediment transport pathways at Teignmouth and investigate possible causes for the observed patterns of sediment gains and losses, a coupled wave-flow-morphology model was developed in Delft3D-FM. The model development, calibration, and assumptions are outlined in Appendix C. The following sections summarise the results of the modelling for the following scenarios:

- **Tides only** *mean spring and neap tide flows, no waves*
These 3-day simulations show the residual (net) sediment transport fluxes due to tidal flows with opposing flow directions during different stages of the tide.
- **Storm waves** *storm threshold waves from the south and east, with mean spring tide*
These simulations show the net fluxes due to storm-threshold wave events from the south and from the east, revealing the level of sediment transport that occurs when energetic waves and tides are combined.
- **Multi-annual conditions** *21-month simulation with real waves and tides*
Simulating varied wave and tide conditions over a multi-annual timeframe provides additional insights into net fluxes, indicating the residual sediment transport patterns after wave and tidal flows from opposing directions have occurred.
- **Influence of existing navigational dredging** *21-month simulation with real waves and tides*
These simulations show the difference in predicted transport fluxes and bed levels with and without grab dredging accounted for. Details of the simulated dredging regimes are provided in Section 6.

It should be noted that the sediment fluxes presented here are sensitive to the grain size(s) applied in the model. Informed by measured sediment sizes (Section 3.2), a representative grain size of 1 mm (very coarse sand) was applied in the model along the coastal frontage, which represents an overall average grain size for the intertidal beach sediments. Within the estuary and ebb-tidal delta, coarser sediment with a characteristic grain size of 3 mm was applied, which represents an average size for sediments measured within the estuary channels. As the sediment size varies significantly spatially and has a strong influence on the predicted fluxes, a sensitivity analysis is presented in Section 5.4.

5.1 Tides only

The simulations forced by tides alone reveal that the net sediment transport flux driven by tidal currents is, in most places, close to zero (Figure 5-1). Therefore, while tidal currents may cause sediment transport to occur, the net effect of opposing tidal flows is to result in negligible change in sediment volume along most of Teignmouth's coastal frontage. Exceptions to this occur in the direct vicinity of the estuary mouth, where under spring tide conditions non-negligible net fluxes occur. The model predicts net seaward transport of 37 m³/day through the ebb-tidal delta via the main inlet channel under

spring tides. Conversely, the estuary mouth itself is predicted to have a net landward flux into the estuary of 3 m³/day, despite the ebb-dominant flows. This is likely to be a result of the considerably coarser sediment modelled inside the estuary (3 mm) being less mobile during the ebb tide than the finer material outside the estuary (1 mm) on the flood tide. At Shaldon Bridge, net fluxes under spring tides are predicted to be seaward directed with a magnitude of 21 m³/day, although this only considers estuarine transport and disregards fluvial sediment inputs. Under neap tides, net tidally driven sediment fluxes are negligible (≤ 1 m³/day) in all locations (Figure 5-1, lower panel).

The beaches in Teignmouth are therefore not expected to significantly change when tides alone are acting, for example, during calm wave conditions, as negligible net fluxes are predicted at the shoreline across most of the frontage. The only exception to this is the area immediately surrounding the estuary mouth at Denn Spit and Shaldon Beach, where net seaward fluxes of 3-6 m³/day are expected to occur during spring tides. However, these fluxes should be considered approximate, as the grain size varies considerably within the estuary mouth and ebb-tidal delta, and the predicted fluxes are sensitive to the sediment sizes used in the model (Section 5.4).

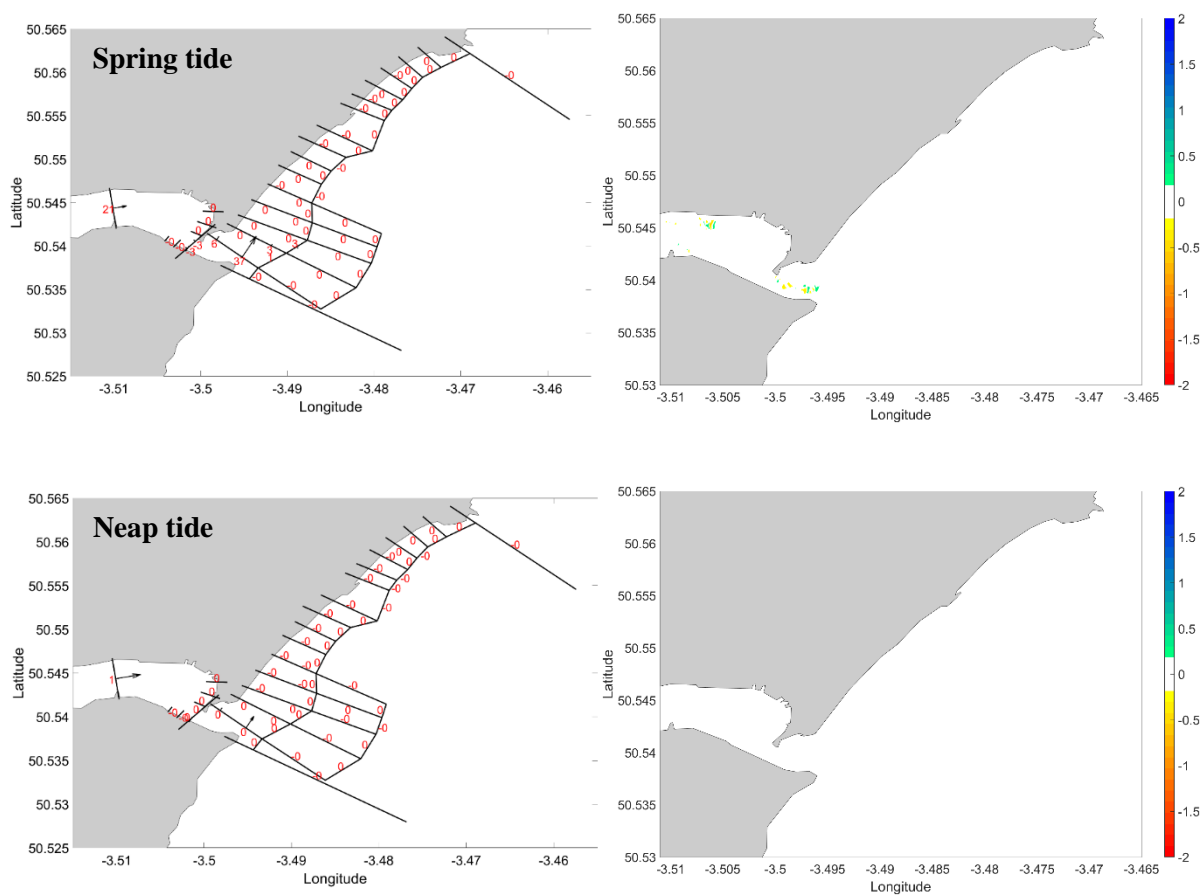

Figure 5-1. Net sediment transport fluxes (left panels; m³/day) and bed level change (right panels; m) predicted by the Delft3D-FM model for a 3.5-day tide-only simulation (Section C.3) under mean spring tides (upper panels) and mean neap tides (lower panels). Alongshore net fluxes are predicted at the locations of SWCMP interim profiles (See Figure 4-1. and Figure 4-2.) and bounding headlands, while cross-shore fluxes are predicted at the DoC contour (-5.4

mODN) for the coastal frontage, plus the 10 m depth contour for the ebb-tidal delta. Positive fluxes are northward and/or eastward.

5.2 Storm waves

Net sediment fluxes under storm wave conditions vary depending on the direction of wave approach. Under southerly storm waves (Figure 5-2, upper panels), net fluxes along Teignmouth Seafront Beach are from south to north and are predicted to increase rapidly from Denn Spit ($1 \text{ m}^3/\text{day}$) to Teignmouth Pier ($169 \text{ m}^3/\text{day}$). Net northward fluxes then continue to increase along the Seafront Beach, peaking at Sprey Point ($954 \text{ m}^3/\text{day}$). The northward sediment flux is reduced immediately north of Sprey Point ($522 \text{ m}^3/\text{day}$), illustrating that it has a similar effect to a small headland. Net flux then increases again between Sprey Point and Holcombe headland ($706 \text{ m}^3/\text{day}$) before reducing immediately adjacent to Holcombe headland ($253 \text{ m}^3/\text{day}$). The sharp increase in net flux predicted between Teignmouth Lighthouse and Teignmouth Pier (profiles 6b00204–6b00209) indicates that sediment is removed efficiently from this area under southerly storm threshold waves, losing $\sim 0.7 \text{ m}^3/\text{m}/\text{day}$. Sediment deposition is then predicted at Sprey Point and Holcombe Headland (Figure 5-2, upper right panel), where decreasing gradients in flux occur.

Under easterly storm waves (Figure 5-2, lower panels), net sediment fluxes along Teignmouth Seafront Beach are from north to south. Net fluxes increase from Holcombe Headland ($678 \text{ m}^3/\text{day}$) and peak immediately south of Sprey Point ($3,000 \text{ m}^3/\text{day}$), at which point fluxes decrease towards Teignmouth Pier ($762 \text{ m}^3/\text{day}$) and rapidly diminish between Teignmouth Pier and Denn Spit ($1\text{-}6 \text{ m}^3/\text{day}$). The predicted gradients in flux indicate that during easterly waves, sediment is transported back towards Teignmouth Pier efficiently, with sediment likely to be eroded immediately south of Holcombe Headland and Sprey Point, where increasing transport gradients occur, and deposited at the southern end of Teignmouth Seafront Beach, where a sharp decrease in flux is predicted (Figure 5-2, lower right panel). The model predicts there would be gains of $\sim 4 \text{ m}^3/\text{m}/\text{day}$ around Teignmouth Pier (profiles 6b00204–6b00209) during storm threshold waves from the east.

Predicted transport rates during easterly waves are approximately double those of southerly waves of the same return period. This is surprising, given that the storm-threshold waves from the east are approximately 50% lower than those from the south. The increased transport potential during easterly waves is therefore likely to be due to the shoreline being drift aligned by the dominant southerly wave approach, as alongshore sediment transport potential is a product of both the wave power and angle of approach relative to the local shoreline (Shore Protection Manual, 1984).

At the headlands bounding the northern and southern extents of Teignmouth, the model predicts a significant quantity of sediment bypassing during storm threshold waves with a spring tide (Figure 5-2, left panels). Under southerly storm waves, net fluxes of $537 \text{ m}^3/\text{day}$ are predicted to enter the frontage

from the south around Ness Point, while 350 m³/day are predicted to exit the frontage to the north around Holcombe Headland (giving a net input of 187 m³/day). Conversely, under easterly storm waves, 282 m³/day is predicted to enter the frontage from the north around Holcombe Headland, and 867 m³/day is predicted to exit the frontage to the south around Ness Point (giving a net loss of 585 m³/day).

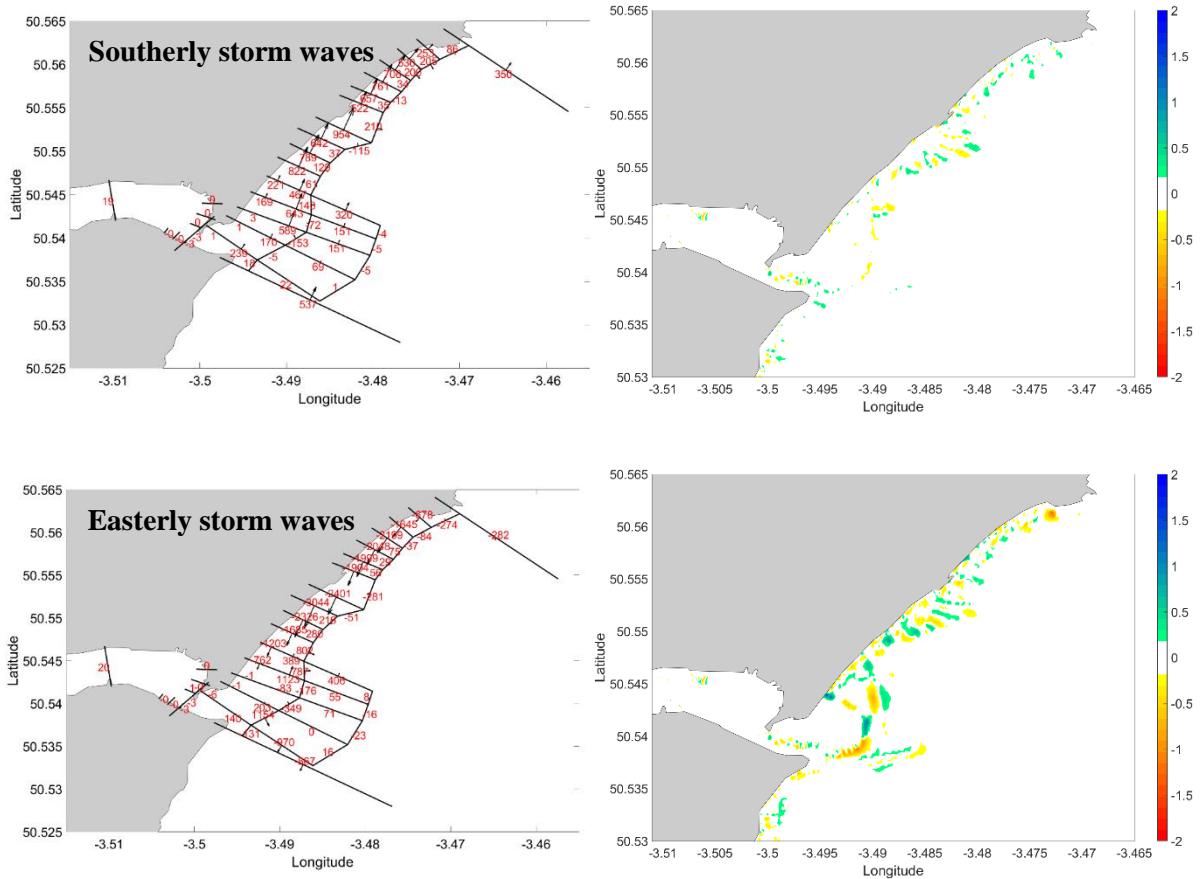

Figure 5-2. Net sediment transport fluxes (left panels; m³/day) and bed level change (right panels; m) predicted by the Delft3D-FM model for a 3-day simulation under storm threshold waves from the south (upper panels) and east (lower panels), combined with mean spring tides (Section C.3). Alongshore net fluxes are predicted at the locations of SWCMP interim profiles (See Figure 4-1. and Figure 4-2.) and bounding headlands, while cross-shore fluxes are predicted at the DoC contour (-5.4 mODN) for the coastal frontage, plus the 10 m depth contour for the ebb-tidal delta. Positive fluxes are northward and/or eastward.

5.3 Multiannual conditions

Over the 21-month simulation with waves from both the south and the east, Teignmouth's coastal frontage is predicted to be dominated by south to north directed sediment transport (Figure 5-3, left panel). Between Teignmouth Lighthouse and Teignmouth Pier, a sharp increase in flux occurs along the shore (160–12,000 m³/year), indicating that considerably more sediment is transported away from this area to the north than is arriving from the south, over a multi-annual timeframe. This gradient in flux is due to increasing wave height and angle at the shore moving northward from Teignmouth Lighthouse, caused by the enhanced wave dissipation and refraction that occurs over the ebb-tidal delta.

North of Teignmouth Pier, beyond the vicinity of the ebb-tidal delta, net sediment fluxes are predicted to be between 25,000–47,000 m³/year to the north. At the northern extent of Teignmouth, a convergence is predicted to occur between the dominant south to north sediment transport, and localised fluxes adjacent to Holcombe Headland. The predicted bed level changes (Figure 5-3, right panel) indicate that sediment is gradually moved northwards over the 21-month simulation. Cross-shore transport is also noticeable, with 0.5-1 m of storm cut and fill predicted across the beach on the exposed seafront.

Within the vicinity of the ebb-tidal delta, net sediment fluxes are predicted to be higher than the wave-driven fluxes predicted away from the estuary, due to the high velocity and ebb dominance of the estuary flows. The estuarine fluxes are directed northwards and seawards and are highest near the estuary mouth (~77,000 m³/year) and decrease northwards and seawards as the estuary flows spread out at the edge of the delta (~64,000 m³/year). The estuary exchanges a significant amount of sediment beyond the theoretical DoC. Across the DoC contour (-5.4 mODN; Section 2.3.5), net fluxes in the ebb-tidal delta are predominantly seaward, while at the 10 mODN depth contour (approximately the outer edge of the ebb-tidal delta) where wave shoaling is the dominant process, onshore sediment fluxes towards the ebb-tidal delta are predicted. This indicates that the convergence of suspended sediment from the ebbing estuary flows and onshore transport due to wave shoaling, form the outer lobes of the ebb-tidal delta (i.e. the Ness Pole and Outer Pole, Figure 3-5).

Despite the ebb-dominance of the estuary, the model predicts a net flux of ~8,500 m³/year of sediment import into the estuary through the estuary mouth. This is likely to be a result of the considerably coarser sediment modelled inside the estuary (3 mm) being less mobile during the ebb tide than the finer material outside the estuary (1 mm) on the flood tide. This is also in line with previous findings from Bernardes (2005) who found that despite the ebb dominant flows, wave stirring induces net landward fluxes of sediment into the estuary. Opposing net fluxes are predicted between the estuary mouth (landward net flux) and Ness Point (seaward net flux), leading to predicted bed lowering in the main inlet channel and eastern end of Shaldon Beach (Figure 5-3, right panel).

Over the 21-month simulation, headland bypassing is predicted to bring a net flux of 31,000 m³/year of sediment into Teignmouth from the coastline south of Ness Point. At Holcombe Headland, a comparable magnitude of sediment is predicted to be exchanged northward, with a predicted net flux of 24,000 m³/year out to the north. Therefore, based on the forcing applied in this simulation, the necessary assumptions regarding sediment size and availability, and disregarding the existing dredge and disposal practices, alongshore sediment exchange with the wider coastline is predicted to occur, with a modest net sediment gain of 7,000 m³/year predicted to enter the frontage.

47 To refer to the work within this report, please cite as:
Coastal Marine Applied Research, 2025 Teignmouth Beach Management Plan: Coastal Processes
Baseline Assessment. Report 2005_d1v3. University of Plymouth Enterprise Limited, 175 pp.

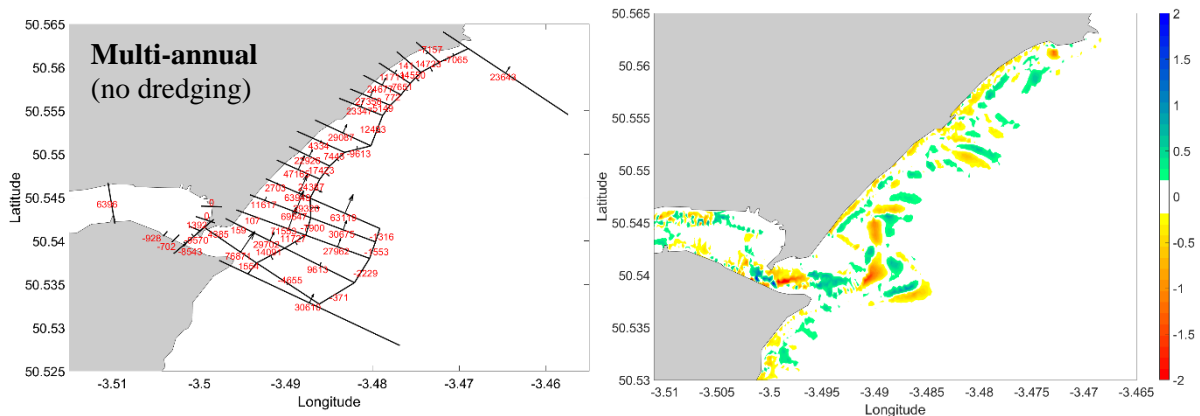

Figure 5-3. Net sediment transport fluxes (left panels; m³/year) and bed level change (right panels; m) predicted by the Delft3D-FM model for a 21-month simulation with varying wave and tide conditions (Section C.3). Dredging was not included in this simulation. Alongshore net fluxes are predicted at the locations of SWCMP interim profiles (See Figure 4-1. and Figure 4-2.) and bounding headlands, while cross-shore fluxes are predicted at the DoC contour (-5.4 mODN) for the coastal frontage, plus the 10 m depth contour for the ebb-tidal delta. Positive fluxes are northward and/or eastward.

5.4 Sensitivity to modelled sediment size

Teignmouth features a wide range of sediment sizes, which vary spatially by an order of magnitude (Section 3.2). The heterogeneity of the sediments, especially in the estuary and ebb-tidal delta, make it challenging to achieve realistic predictions of flux in all locations using only one or two sediment classes. The results presented in Sections 5.1–5.3 assume a representative D_{50} grain size of 1 mm on the exposed frontage, and 3 mm applied within the ebb-tidal delta and estuary (Section C.4), informed by previously measured values. The following sections summarise the difference between the results predicted in Section 5.3 and two sediment sensitivity tests (Section C.7.2) using finer grain sizes on the exposed frontage and inside the estuary. The real sediment fluxes are expected to sit somewhere within the range of predicted values from these sensitivity tests, as they cover the lower to upper ranges of observed grain sizes at Teignmouth.

5.4.1 Finer beach sediment (Estuary $D_{50} = 3$ mm, Beach $D_{50} = 0.3$ mm)

When a finer sediment size of $D_{50} = 0.3$ mm is used on the exposed frontage outside the ebb-tidal delta and estuary, representing the lower range of the measured beach grain sizes (typically found on the lower intertidal and subtidal regions), the predicted transport fluxes are much higher. Net fluxes on the Seafront Beach are up to 225,000 m³/year to the north and exceed 300,000 m³/year through the ebb-tidal delta. These fluxes are approximately 4-5 times higher than the results reported in Section 5.3. within the estuary, however, fluxes are not altered significantly.

5.4.2 Finer estuary sediment (Estuary $D_{50} = 1$ mm, Beach $D_{50} = 1$ mm)

When a finer sediment size of $D_{50} = 1$ mm is applied inside the estuary and ebb-tidal delta, larger fluxes are predicted in all locations, as a significant amount of sediment is flushed from the estuary. In this case, predicted net fluxes approach 74,000 m³/year on the Seafront Beach and 280,000 m³/year through the estuary inlet channel. These fluxes are approximately 1.5-4 times higher than the results reported in Section 5.3; inside the estuary, however, fluxes are 20-30 times higher. $D_{50} = 1$ mm is considered unrealistic for the estuary as it is much finer than measured sediment from the estuary channels, and significant morphodynamic changes to The Salty are predicted that are not observed in reality. Meanwhile, in the ebb-tidal delta, while gravel and even cobbles are observed in places, 1 mm grain size is not unrealistic for the sediment lobes, or for the beach sediment on Denn Spit.

Interestingly, the model predicts a divergence in flux around the location of Teignmouth Lighthouse when 1 mm grain size is used, which is not predicted using the coarser 3 mm sediment within the ebb-tidal delta. The predicted north to south net flux under the 1 mm scenario represents the expected transport direction, given the spit extends towards the south. Net fluxes along Denn spit are of a similar order of magnitude (~4,000 m³/year) but are reversed in direction under the 1 mm scenario compared to when 3 mm grain size is used within the ebb-tidal delta. Real sediment fluxes within the ebb-tidal delta are likely to sit within the range of predictions of these two simulations - the values along Denn Spit are expected to be more realistic with 1 mm sediment (due to the drift direction), while values through the inlet channel and within the estuary are considered more realistic with 3 mm sediment when compared to observed bed level changes.

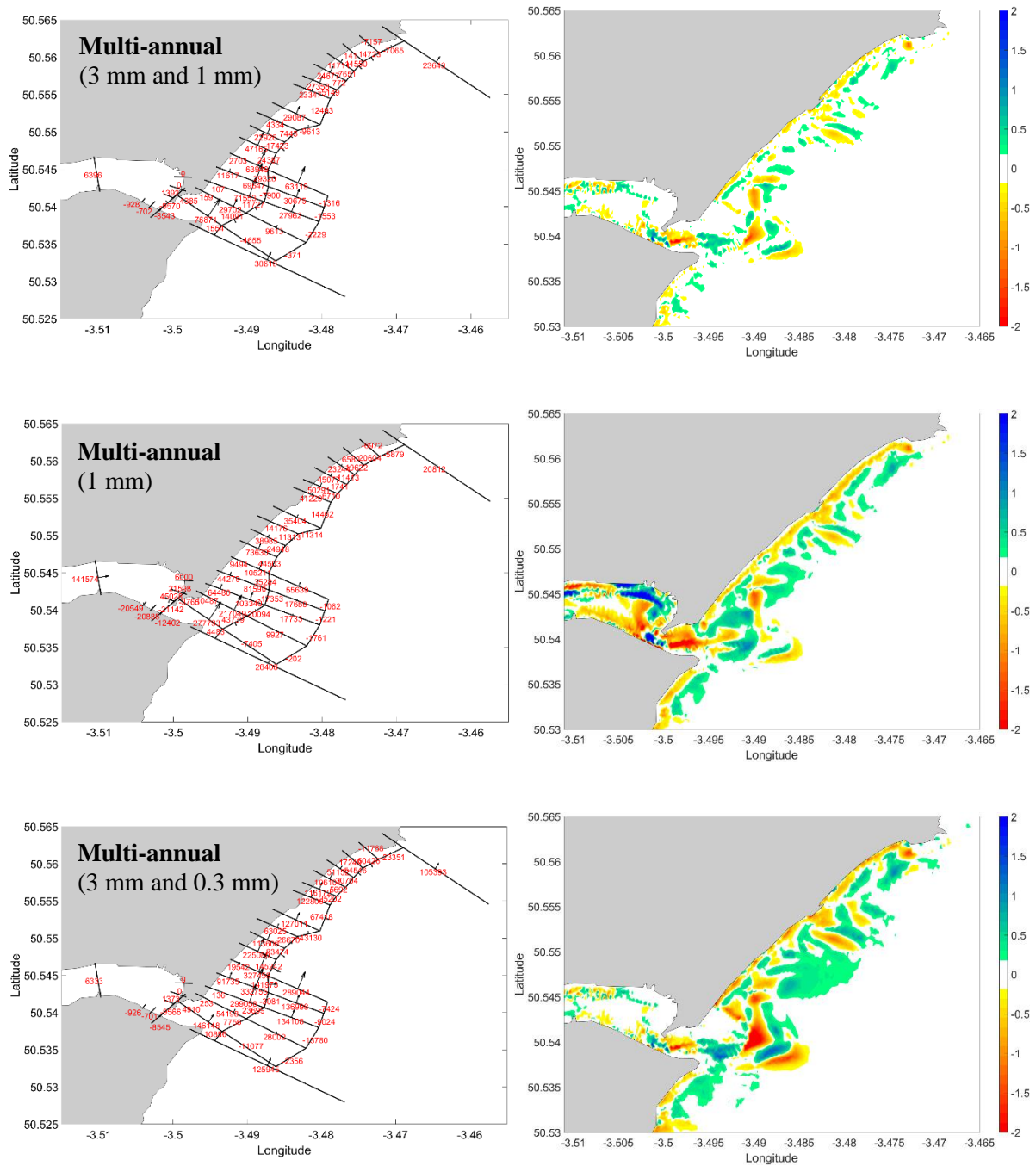

Figure 5-4. Net sediment transport fluxes (left panels; $m^3/year$) and bed level change (right panels; m) predicted by the Delft3D-FM model for an 21-month simulation under varying wave and tide conditions (Section C.3). Predictions are provided for 3 mm/1 mm (upper panels), 1 mm (middle panels), and 3mm/0.3 mm (lower panels) D_{50} sediment sizes applied in the model (Section C.4). Alongshore net fluxes are predicted at the locations of SWCMP interim profiles (See Figure 4-1. and Figure 4-2.) and bounding headlands, while cross-shore fluxes are predicted at the DoC contour (-5.4 mODN) for the coastal frontage, plus the 10 m depth contour for the ebb-tidal delta. Positive fluxes are northward and/or eastward.

6 Influence of existing navigational dredging

6.1 Modelling approach

Dredging is conducted routinely at Teignmouth to maintain a navigational channel through the estuary mouth. The dredging routine includes drag (plough) dredging on a daily-weekly basis to remove surficial sediments from the estuary channel immediately inside and outside the estuary mouth, as well as grab dredging on a less frequent basis to remove sediment that has accumulated at the head of the inlet channel in the ebb-shoal delta. The grab dredging is associated with a licence for the removal of 45,000 tonnes of sediment per year, with a licenced disposal site adjacent to Sprey Point. This is presumed to have the intention of nourishing the shoreline at that location using the dredge material.

The effects of the dredging regime were studied by simulating scenarios with and without grab dredging and disposal implemented in the Delft3D-FM model. The model was run over a multi-annual scenario (Section 5.3), and the changes in erosion/deposition patterns, as well as differences in the predicted fluxes, provide insight into how the dredging currently affects sediment transport pathways at Teignmouth. As there is uncertainty around the exact quantity of grab dredging that occurs each year, two grab dredging scenarios were simulated in the model:

- **45,000 tonnes per year**; the maximum licenced dredge quantity allowed each year.
- **15,000 tonnes per year**; a lower estimate, based on quantities stated in a previous sediment recharge study conducted for Teignmouth (ABPmer, 2012b).

In each case, the model removes the volume gradually throughout the simulation, which is a simplification of the sporadic removal that occurs in reality. The full volume removed from the ebb-tidal delta is deposited gradually at the disposal site in the nearshore area adjacent to Sprey Point. Polygons of the estimated areas affected by the dredging activity, based on information from a previous study (ABPmer, 2012b), were used to define the grab and disposal locations (Figure 6-1).

Compared to the grab dredging, the effects of the plough dredging are difficult to quantify, as the sediment concentration suspended by the ploughing will depend on the hydrodynamic conditions occurring at the time, and the sedimentation that has occurred prior to the dredging. However, it can be assumed to have a relatively minor effect on the net sediment fluxes, as the plough dredging simply promotes sediment suspension during the ebbing tide, while natural currents are left to move the sediment seaward from the estuary mouth. A similar quantity is presumed to return to the estuary on following incoming tides, hence the requirement for regular ploughing to maintain the desired depths. Therefore, for the purposes of the present study the **plough dredging activity was not included in the modelling**.

51 To refer to the work within this report, please cite as:
Coastal Marine Applied Research, 2025 Teignmouth Beach Management Plan: Coastal Processes
Baseline Assessment. Report 2005_d1v3. University of Plymouth Enterprise Limited, 175 pp.

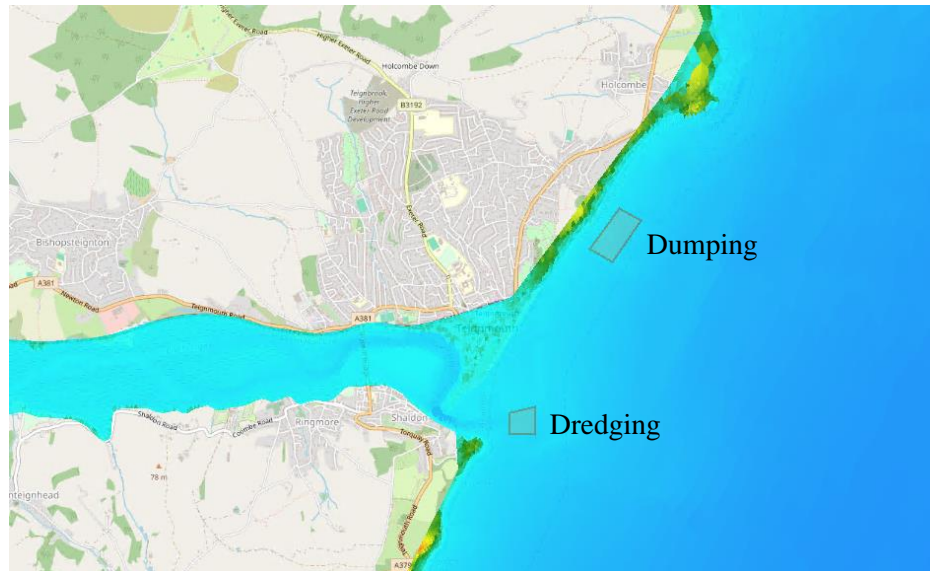

Figure 6-1. Model domain with approximated dredging and dumping areas utilized in the simulations.

6.2 Lower estimated dredge quantity

Under the lower estimated dredge quantity, the south to north net fluxes along the Seafront Beach are, in most places, not predicted to change more than 10%. However, larger impacts are predicted to occur just south of Sprey Point and just south of Holcombe Headland, where reductions in the northward flux of 42% and 62% are predicted, respectively. Although these percentages are large, the absolute change in predicted flux at these locations is <1,000 m³/year, as these represent localised areas of low net flux with or without dredging. Maximum absolute changes in flux are predicted in the ebb-shoal delta in the vicinity of the grab site, where fluxes are predicted to change by 1,300–2,600 m³/year (3-11%). With the lower estimated dredge quantity, predicted patterns of sediment erosion and deposition are largely similar to those under the no dredging scenario, albeit with ~0.5 m lower and higher bed levels at the dredge grab and disposal sites, respectively.

Inside the estuary and in the area of observed beach lowering between Teignmouth Lighthouse and Teignmouth Pier, the predicted changes to the net fluxes are negligible under the lower estimated dredge scenario. Negligible changes in net flux (≤1%) are also predicted at the bounding headlands to the north (Holcombe Headland) and south (Ness Point), indicating that no changes in sediment exchange with the wider coastline are predicted with the lower estimated dredge quantity implemented.

6.3 Maximum licenced dredge quantity

More significant bed level changes are predicted under the maximum licenced dredge scenario over the 21-month simulation, with ~1 m lower and higher bed levels at the dredge grab and disposal sites, respectively. Bed levels are noticeably altered along most of the exposed frontage and, interestingly, intertidal beach levels are predicted to be more stable under this scenario. The cross-shore cut and fill

(beach deflation) that is predicted in the no-dredging simulation is absent from the predictions under the maximum licenced dredging, suggesting that the dredge disposal at Sprey Point provides some beach protection value. However, the predicted bed levels from this scenario do not seem entirely realistic compared to the observed bed changes over this period, as the predicted bed lowering in the ebb-tidal delta, and bed level increases offshore of Sprey Point, exceed those observed in reality (Section C.6). It is therefore possible that the maximum licenced dredge quantity is an overestimate of the dredging that occurs in reality. However, the simulation is useful to demonstrate the potential effects if the full licenced quantity was dredged and provides an upper estimate of the dredging effects.

Under this more extreme scenario, the northward net flux is predicted to reduce to some degree along the entire frontage. Between Teignmouth Lighthouse and Teignmouth Pier, the net flux along the shore is predicted to be reduced almost completely (~100%), while approaching Sprey Point it is affected far less (-3% to -14%). Immediately north of Sprey Point, the northward net flux is reduced by -40% to -50% under the maximum licenced dredge scenario. The predicted reductions in alongshore flux are possibly due to a reduced supply of sediment from the south, as the inlet bar no longer provides a source of sediment, and due to enhanced wave refraction and dissipation over the dredge disposal site, which would act to reduce alongshore transport.

Possibly the most important predicted effect of the maximum licenced dredge scenario is that the model indicates a significant increase in sediment bypassing to the north around Holcombe Headland under the maximum dredging scenario, where net fluxes are predicted to increase from 24,000 m³/year to 35,000 m³/year (+47%). This is presumably due to the increased supply of sediment offshore of Sprey Point, where wave and tidal currents can mobilise the sediment (even below the theoretical DoC) and transport it further north towards the wider coastline. Meanwhile at Ness Point to the south, the net feed of sediment into the Teignmouth frontage is also predicted to be simultaneously reduced, from 31,000 m³/year to 25,000 m³/year (-19%).

The maximum dredging scenario is therefore predicted to shift the sediment budget at Teignmouth from a positive budget with the wider coastline when no dredging occurs, to a negative budget under the maximum dredging scenario. The predictions suggest that over the long term, sediment will be lost from the frontage at Teignmouth at a rate of approximately 10,000 m³/year under the full licenced dredging scenario, while without dredging approximately +7,000 m³/year should be gained through net import from the south (assuming 3 mm and 1mm sediment inside and outside the ebb-tidal delta, respectively).

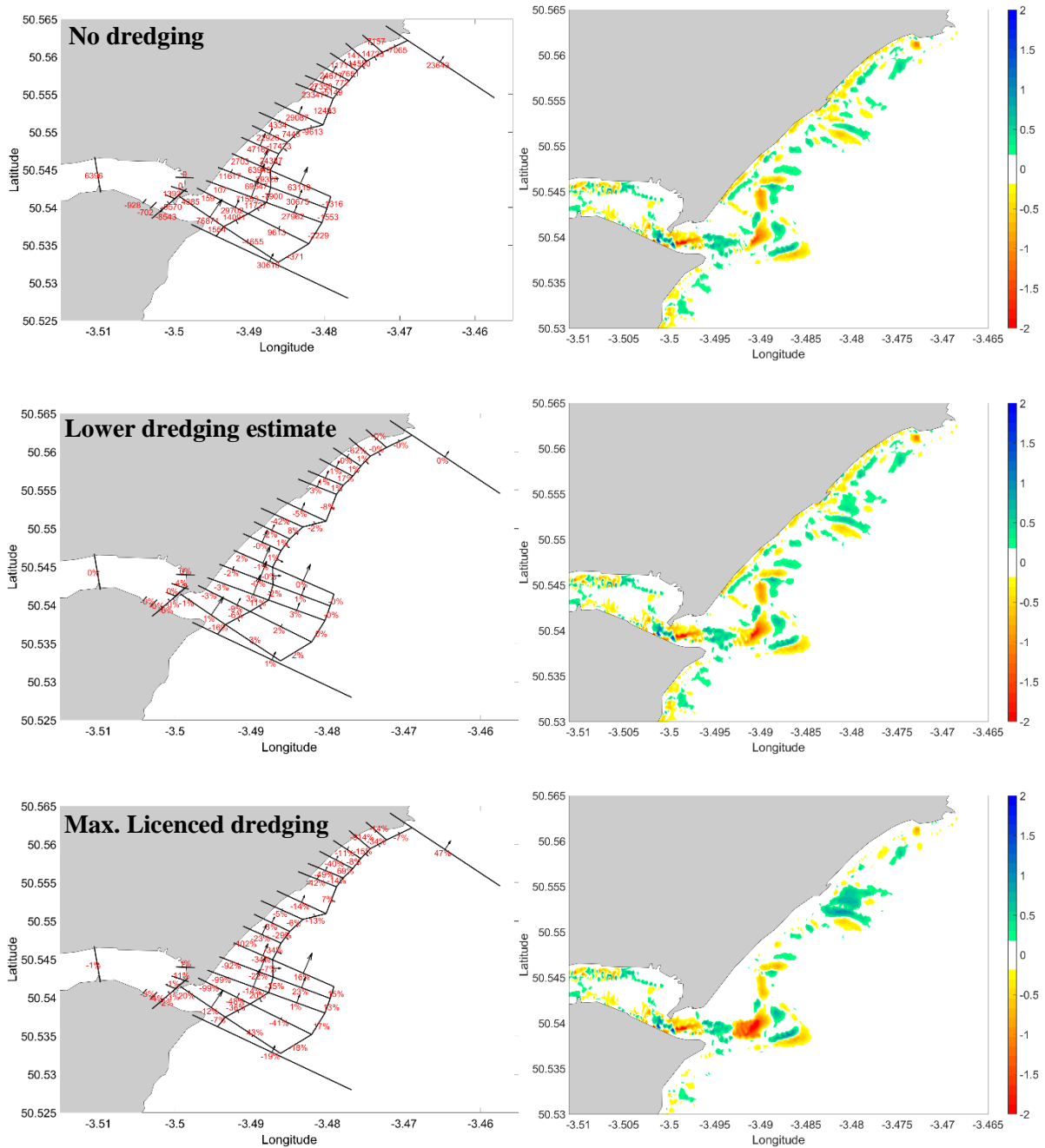

Figure 6-2. Change in net sediment transport flux due to dredging (left panels; %) and bed level change (right panels; m) predicted by the Delft3D-FM model for a 21-month simulation with varied waves and tides (Section C.3). Results are from simulations with no dredging (upper panels), the lower estimated dredge quantity (middle panels), and the maximum licenced dredge quantity (lower panels). Alongshore net fluxes are predicted at the locations of SWCMP interim profiles (See Figure 4-1. and Figure 4-2.) and bounding headlands, while cross-shore fluxes are predicted at the DoC contour (-5.4 mODN) for the coastal frontage, plus the 10 m depth contour for the ebb-tidal delta. Positive fluxes are northward and/or eastward.

7 Potential causes for observed beach lowering

Substantial beach lowering has occurred between Teignmouth Pier and Denn Spit during the 15-year period studied in this report. Of greatest concern is that the beach adjacent to Teignmouth Lighthouse (SWCMP profiles 6b00204-6b00212, Figure 4-1.) has lowered by ~3 m vertically and has lost up to 100 m³/m of intertidal sediment since 2007 (Figure 4-9) at an estimated rate of -5.88 m³/m/year (Appendix B). There are various potential causes for this observed beach lowering, as discussed in the following sections.

7.1 Ebb-tidal delta circulation

The Outer Pole (Figure 3-4 and Figure 3-5) is known to sporadically inject large volumes of sediment back onto the intertidal beach approximately at the location of the observed beach lowering (for example in 2001, Figure 3-6). The sandbank circulation takes on average 40 months (Robinson, 1975), so it would be expected that at least 4 cycles have occurred since the start of the 15-year SWCMP monitoring record. Close inspection of intertidal beach volumes at the worst affected area of beach lowering (SWCMP profiles 6b00204-6b00212) indicate that peaks in sediment volume have indeed occurred at approximately 2-4 year intervals (Figure 4-8). This is assumed to be caused by welding of the Inner Pole/Horseshoe Bank to the shore at this location and represents a significant increase in sediment volume when it occurs (50-100 m³/m). However, these peaks in volume are short-lived, typically reducing again in the following years. The statistically significant negative trend over the 15-year monitoring record suggests that the sandbar circulation alone is not sufficient to maintain beach levels over the long term.

7.2 Alongshore transport gradient

Chronic erosion at a single alongshore location can be symptomatic of a gradient in alongshore sediment transport. In other words, if the littoral drift supply entering a segment of coast is less than the littoral drift supply exiting that segment of coast, then a reduction in beach volume is expected to occur (Figure 7-1).

From the modelling in Section 5.3, a positive gradient in the net south to north sediment flux is predicted between Teignmouth Lighthouse and Teignmouth Pier where the observed beach lowering has occurred. The predicted fluxes in this location depend on the grain size applied in the model (Section 5.4), but indicate that 31–91 m³/m/year could be lost from this area (when 3 mm and 1 mm grain sizes are applied inside the ebb-tidal delta, respectively), and at most 247 m³/m/year (when 0.3 mm grain sizes are applied outside the ebb-tidal delta). These rates are a lot higher than the observed losses, however. This is potentially because they don't account for the existing dredging regime, which, when included in the model results in transport gradients that better match the observed sediment losses (Section 7.5). These predictions also don't account for the Ness Pole circulation sporadically offsetting

55 To refer to the work within this report, please cite as:
Coastal Marine Applied Research, 2025 Teignmouth Beach Management Plan: Coastal Processes Baseline Assessment. Report 2005_d1v3. University of Plymouth Enterprise Limited, 175 pp.

losses during beach welding phases, as the full circulation of the sandbars is not captured by the model. The timber groyne field also probably has some influence on the transport rates along the beach, despite the poor state of most of the groynes. While it is acknowledged that these structures do affect flows and sediment transport to some degree (which is evidenced by slightly different shoreline positions visible either side of many of the groynes), a means to accurately define their efficacy at blocking sediment transport does not exist. Furthermore, structures with partial permeability to sediment transport cannot be implemented in Delft3D. Therefore, they are not included in the model. Due to the poor state of most of the timber groynes, it is estimated that they would alter the predicted fluxes by no more than 20% in their current state (i.e. 80% of sediment transport may continue to occur around or through the groynes). On this assumption, they would act to reduce the magnitude of the losses from this area by a similar percentage (for example, $\sim 25 \text{ m}^3/\text{m}/\text{year}$ under the assumption of 3 mm grain size in the ebb-tidal delta).

Whether or not the circulation of the nearshore bars, the dredging regime, or the timber groyne field significantly alter sediment fluxes in the area of observed beach lowering, the modelling clearly suggests that a gradient in the net south to north flux at the shoreline between Teignmouth Lighthouse and Teignmouth Pier is a likely cause of the observed beach lowering at that location.

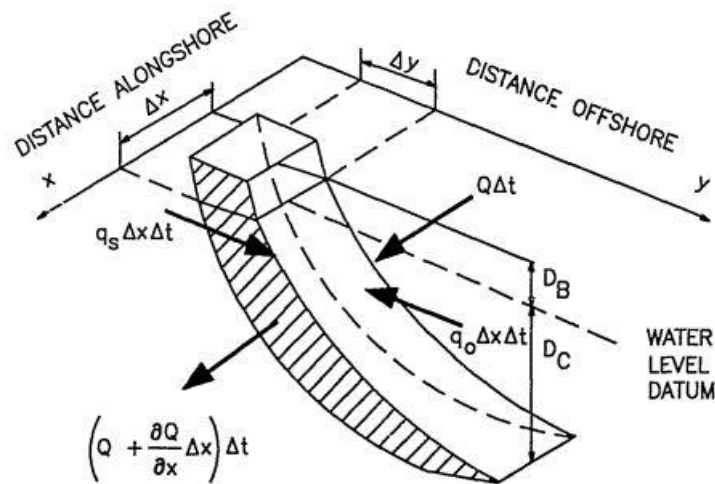

Figure 7-1. Schematic description of shoreline change due to littoral drift, from Hanson and Kraus (1989). Q represents the alongshore transport into and out of the coastal segment, while q_s and q_o represent gains and losses of profile volume. D_B is the height of the berm or beach and D_C is the depth of closure.

7.3 Alongshore transport divergence

Where a divergence in net drift direction occurs (e.g. littoral drift is driven in opposing directions), even greater erosion would be expected. From the modelling undertaken for this study, it has been

demonstrated that flow divergences are likely to occur under certain conditions between Teignmouth Lighthouse and Teignmouth Pier. For example, during flooding and high tide stages, flows are predicted to diverge at this location, particularly when spring tides are combined with southerly storm waves (for example, Figure 2-11). An example of diverging sediment transport occurring at this location can even be seen from aerial imagery, visible as suspended sediment plumes moving in opposite directions (Figure 7-2). This is further corroborated by storm event modelling in XBeach conducted by ABPmer (2012b), which demonstrates such flow divergences during shore normal and southerly wave approaches.

While such a divergence is not predicted to occur at ebbing or low tide stages, or under waves arriving from the east, it is clearly possible that flow divergence can occur at the location where chronic beach lowering has occurred, particularly under the dominant southerly wave approach. The predicted annual sediment fluxes (Section 5.3 and 5.4) do not consistently show a flux divergence in this location. However, when 1 mm grain size is applied throughout the model, which is a reasonable grain size for the intertidal beach, a divergence in littoral transport is predicted to occur approximately at the location of Teignmouth Lighthouse. It is also notable that the flow divergence is predicted to occur at high tide levels when the greatest wave action is expected to occur at the shore. It is therefore considered a strong likelihood that divergences in flow direction and net sediment flux could be contributing to the observed beach lowering between Teignmouth Lighthouse and Teignmouth Pier.

It is also worth noting that a divergence in net sediment flux is not predicted to occur at Sprey Point under any of the simulations, which was previously believed to be the most likely place for a divergence to occur (New Forest District Council, 2017). The shoreline there has also not experienced chronic erosion, which would be the expected result of such a transport divergence.

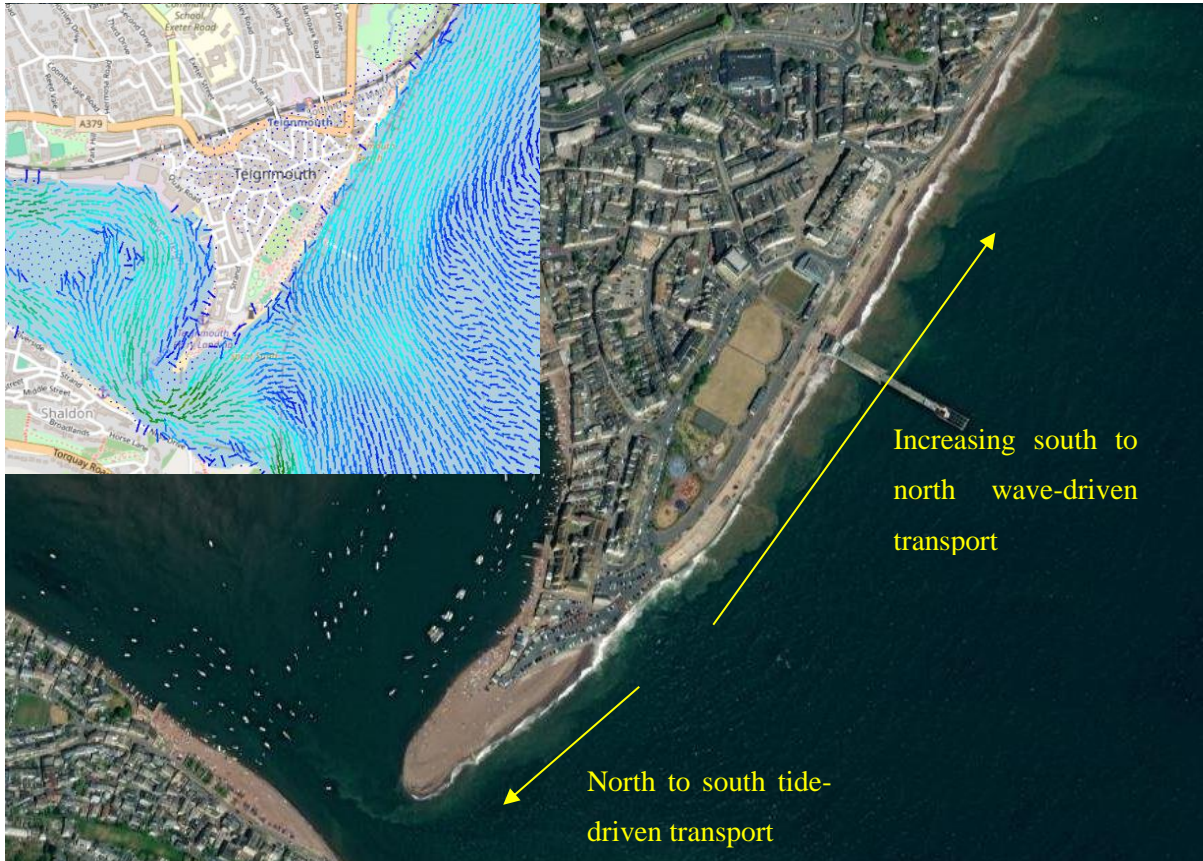

Figure 7-2. Demonstration of suspended sediment being transported in opposing directions from the area of chronic beach lowering, during a flooding-high tide with southerly wave approach. Image courtesy of SWCMP. Inset panel shows modelled flow patterns under equivalent conditions (see Figure 2-11 for description of colours).

7.4 Balance of easterly vs westerly wave conditions

It has been demonstrated that under southerly wave conditions sediment is moved away from the area of observed beach lowering through increasing northward sediment flux as you move north from the lighthouse, and by a possible divergence to southward flux between the lighthouse and Denn Spit (Sections 7.2 and 7.3). Under southerly waves, the beach lowering at the lighthouse is therefore exacerbated, although the frontage as a whole is predicted to gradually gain sediment due to headland bypassing bringing more material from the south around Ness Point than is lost to the north around Holcombe Headland (Section 5.2). Conversely, under easterly wave conditions, sediment is moved quite efficiently back from the northern end of the Seafront Beach towards the area of observed beach lowering (Section 5.2). Under easterly waves, the beach lowering at the lighthouse is therefore naturally re-nourished, although the frontage as a whole is expected to lose sediment during easterly waves due to headland bypassing exporting more material to the south around Ness Point than is gained from the north around Holcombe Headland.

The dominant wave approach is from the south, with >70% of the total wave power arriving from that directional sector (Section 2.3). The removal of sediment from the beach between Teignmouth

Lighthouse and Teignmouth Pier during waves from the south, and the dominance of waves arriving from that direction, are therefore likely to be root causes for the observed beach lowering.

Furthermore, analysis of long-term wind records at nearby Start Bay by Scott et al. (2016) showed that easterly wave conditions on this coastline have declined significantly since the 1950's. Easterlies contributed approximately 30% of the east/south balance of storm waves ($H_s > 2.5$ m) during the 1950s to 1980s, and then dropped to less than 10% after 1990 (Figure 7-3). This has been linked to shifts in the distribution of atmospheric pressure and resulting storm tracks across the Atlantic Ocean, with easterly storm conditions only developing during periods of negative North Atlantic Oscillation (NAO), which have declined in the last 30 years (Castelle, Dodet, Masselink, & Scott, 2017). As a result, there has been a 75% reduction in the 10-year averaged activity of easterly storms with $H_s > 2.5$ m arriving at this coast since 1990 (Scott et al., 2016). In contrast, southerly storm activity has stayed relatively constant over that period (Figure 7-3). This suggests that conditions required to naturally re-nourish the area of observed beach lowering at the southern end of the Seafront Beach have become increasingly rare in recent decades, although it is not possible to say whether this decline in easterly waves will continue into the future.

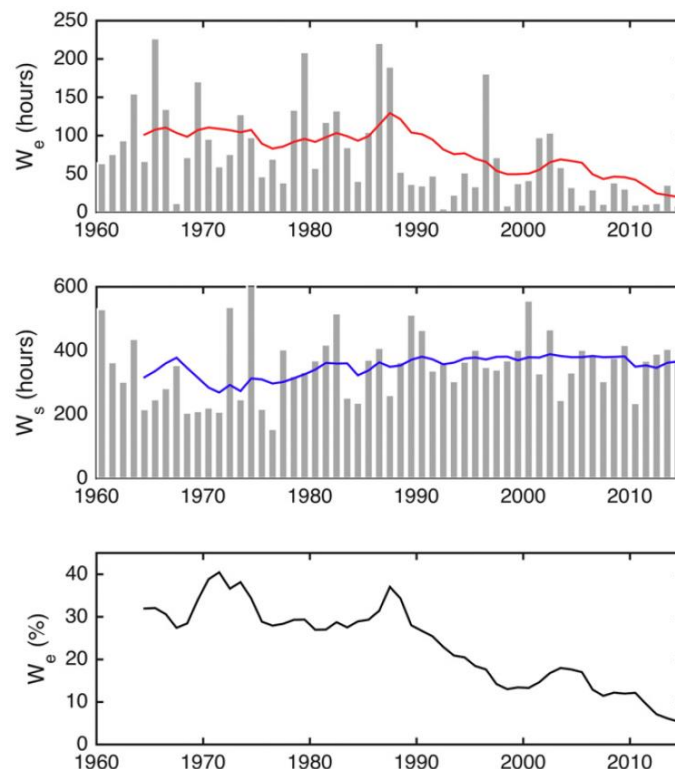

Figure 7-3. Long term contribution of east and south storms at nearby Start bay from Scott et al. (2016). Upper panels show histograms of hourly frequency of easterly (W_e) and southerly (W_s) wave events with $H_s > 2.5$ m in grey with the red and blue lines indicating the 10-year moving average (backwards-looking) for easterly and southerly events, respectively. Wave heights were calculated from local wind records using the SMB method (US Army Corps Of Engineers, 1984). The lower panel shows the percentage contribution of 10-year average W_e to the W_s/W_e balance.

7.5 Dredging activities

The existing grab dredging regime removes sediment from the ebb-tidal delta and places it at Sprey Point. This could be seen as a potential cause of the beach lowering observed between Teignmouth Lighthouse and Teignmouth Pier, as it could be argued that this would create a sink near the proximity of beach lowering and a source further downdrift. However, when grab dredging is included in the model, the predicted transport flux gradient at the location of observed beach lowering actually decreases (Figure 6-2). With dredging implemented in the model, the predicted losses through transport gradients at the shore between Teignmouth Lighthouse and Teignmouth Pier are reduced to somewhere between $-2.6 \text{ m}^3/\text{m}/\text{year}$ (maximum licenced dredging regime) and $-30 \text{ m}^3/\text{m}/\text{year}$ (lower estimated dredge quantity). This range of predicted losses is lower than those predicted without dredging implemented in the model ($31 \text{ m}^3/\text{m}/\text{year}$ for the same sediment size) and are on the same order of magnitude as the observed trend in beach volume, which is up to $-5.88 \text{ m}^3/\text{m}/\text{year}$.

The changes in littoral drift gradients suggest that the dredging can potentially be seen as having a mitigating effect on the observed beach lowering. However, of a greater concern is the predicted increase in sediment exchange with the wider coastline under the maximum licenced dredging scenario (Section 6.3), which indicates that net sediment transport to the north around Holcombe Headland could be enhanced (+47%), while net sediment import from the south could be reduced (-19%). This suggests that over the long term, as much as $10,000 \text{ m}^3/\text{year}$ of sediment could be lost from Teignmouth's overall sediment budget (assuming 3 mm and 1mm sediment inside and outside the ebb-tidal delta, respectively), which would be expected to exacerbate the beach lowering effect over the long term, as well as gradually contributing to a reducing sediment budget at Teignmouth.

The maximum licenced grab dredging quantity and existing grab and disposal locations, are therefore predicted to change the net sediment budget at Teignmouth from a positive sediment budget ($+7,000 \text{ m}^3/\text{year}$) to a negative budget ($-10,000 \text{ m}^3/\text{year}$).

8 Future coastal evolution

8.1 Modelling future coastal squeeze

To make projections of future beach evolution, the *ShoreTrans* (McCarroll et al., 2021) model was used. ShoreTrans is a profile evolution model designed to make ‘Bruun Rule’ type predictions, but with consideration of site-specific factors such as alongshore trends in sediment supply, presence of underlying bed rock, and coastal squeeze due to seawalls. A description of the ShoreTrans model is provided in Appendix D.1. We apply ShoreTrans here using a monte-carlo approach (Appendix D.2), whereby an ensemble of 1000 model predictions are made for each location, each with the input parameters (rate of SLR, sediment supply trend, DoC, erosion width; Table D-1) perturbed around their expected value in order to capture the uncertainty in the input variables. The result of the monte-carlo modelling is a probability distribution of future beach profile shapes, from which the expected (50th percentile) profile can be drawn, as well as upper and lower confidence bounds (5th and 95th percentiles) on that prediction.

The following sections describe the results of the ShoreTrans modelling for Teignmouth’s Seafront Beach, Point Car Park to Teignmouth Spit, Teignmouth Back Beach, and Shaldon Beach. Results figures for each modelled profile are provided in Section D.3. A description of the model inputs, as well as the assumptions and limitations of the modelling are provided in Appendix D.2. Adjustments made to define the active beach face on both the exposed Seafront Beach and the sheltered estuary beaches are described in Section D.2.3.

It should be noted that the predictions here ignore the fact that estuary flow and sediment dynamics are likely to change as sea level rises. For example, tidal prism and flow volumes could increase as sea level rises, and the change in estuary flow could have a significant effect on the morphology of the inner and outer estuary beaches. Modelling future estuary dynamics is beyond the scope of the present study and carries high levels of uncertainty. Therefore, the possible effects of changing estuary dynamics on sedimentation have not been assessed in the present study, although observed trends in sediment volume are considered below.

It is also expected that as sea levels rise nearshore water depth will increase, potentially allowing larger waves to reach the shore at Teignmouth. In addition, there is also potential for the wave climate in the southwest region as a whole to either become more or less energetic in future. Modelling under UKCP18 indicates that future changes in wave are likely to vary around the UK coast, with some parts of the UK projected to have larger waves in future, while other parts are projected to have smaller waves in future. However, future projections of wave climate are considered too uncertain at present to make confident predictions. As such, potential increases in nearshore wave heights have not been explored in the present study.

61 To refer to the work within this report, please cite as:
Coastal Marine Applied Research, 2025 Teignmouth Beach Management Plan: Coastal Processes
Baseline Assessment. Report 2005_d1v3. University of Plymouth Enterprise Limited, 175 pp.

8.1.1 Teignmouth Seafront Beach

Over medium (months-years) to long (years-centuries) time scales, the response of Teignmouth's Seafront Beach is expected to be primarily governed by alongshore gradients in sediment transport rate, rising sea level, and coastal squeeze. This will also be constrained and influenced by the presence of underlying bed rock, where present, which will control the amount of sediment available for profile adjustment and may dictate the lower bounds of beach lowering.

Ignoring existing sediment transport fluxes, rising sea level and coastal squeeze are predicted to universally lower beach levels along Teignmouth's Seafront Beach. By 2120, beach elevations at the toe of the railway seawall are predicted to be 1-2 m below ODN elevation, while further south, toe elevations along Teignmouth's Seafront Beach are predicted to be as low as 3.5 m below ODN elevation by 2120, if existing sediment supply trends are ignored. In this scenario, parts of the Seafront Beach are predicted to be submerged throughout an average tide as early as 2040, while other parts are not predicted to be submerged until 2070-2100. As sediment supply trends are ignored in this scenario, the different degrees of beach lowering predicted along the frontage can be attributed to both the presence of exposed bed rock in front of the railway seawall, which limits the depth of beach lowering, and a slightly shallower foreshore slope in the southern half of the frontage (approximately 0.01) compared to the northern half of the frontage (approximately 0.02), which increases the horizontal retreat predicted.

When existing sediment supply trends are factored in, the predicted evolution of the beach differs substantially along the frontage, with accelerated lowering predicted in some places and decreased lowering or even progradation of the beach predicted in other places. In the northern half of the beach fronting the railway line (profiles 6b00153 - 6b00191), an increasing sediment volume trend has been observed over the last 15 years, with annual sediment gains of on average +3 m³/m/year (range +1 to +9 m³/m/year) at each SWCMP profile. Projecting these trends into the future, ShoreTrans predicts the northern half of the beach will experience relatively little beach lowering under SLR (on the order of 0.5-1 m lower than present day) and is even likely to prograde in places (for example, Figure 8-1). This would maintain a usable beach during low tide levels at most places in front of the trainline. The exception would be profiles immediately north of Sprey Point (profiles 6b00169 and 6b00172), which have experienced only modest gains in sediment over the last 15 years (~1 m³/m/year) and are predicted to be submerged at low tide by 2060-2090.

Along the southern half of Teignmouth's seafront beach (profiles 6b00198 - 6b00212) the profiles have exhibited a decreasing sediment volume trend over the last 15 years, with annual sediment losses of on average -4 m³/m/year (range -9 to -0.4 m³/m/year) at each SWCMP profile. As a result, these profiles are predicted to experience accelerated beach lowering in the future. Profile 6b00198 (the 'pivot point'

of the south to north shoreline rotation) has exhibited little trend in volume over the monitoring record and is projected to lower to around -3.5 mODN at the seawall toe by 2120 and could be submerged by 2060. Conversely, profiles from the pier to the estuary (6b00204, 6b00209, and 6b00212) have experienced the greatest sediment losses over the last 15 years, and are predicted to be lowered to between -2 to -5 m ODN (i.e. as low as the theoretical depth of closure) by 2120 (for example, Figure 8-2). The beach there is either already submerged at low tide (profile 6b00212) or is likely to be submerged by 2030 (profile 6b00209) to 2050 (profile 6b00204).

The uncertainty in the projections along Teignmouth’s Seafront Beach increase over time. The lower (5th percentile) confidence bound gives an indication of the worst-case projections. These indicate that beach levels immediately in front of the seawall could drop below MLW level along the majority of the beach by 2120, even where sediment gains have occurred in the past (for example, Figure 8-1). Therefore, a worst-case scenario projection of future beach levels is that a subaerial beach is not present along most of Teignmouth’s seafront by 2120, even in places where existing positive sediment supply trends have occurred.

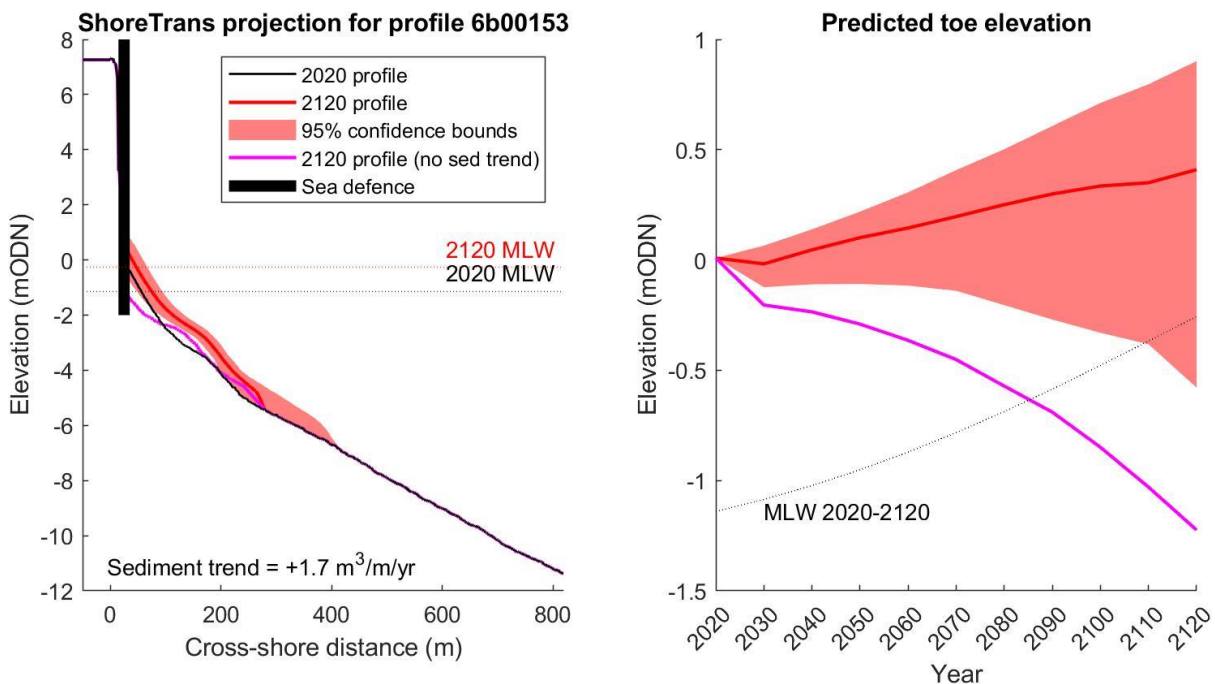

Figure 8-1. ShoreTrans results for profile 6b00153 on Teignmouth’s Seafront Beach (see Figure 4-1 for location). Left: predicted cross-sectional profile evolution between 2020 and 2120. Right: predicted beach elevation at the toe of the seawall over time. Results are shown with (red) and without (magenta) inclusion of existing sediment supply trends. Mean Low Water (MLW) elevation is shown for reference. The sea defence cross-shore position is indicated, but toe depth is unknown.

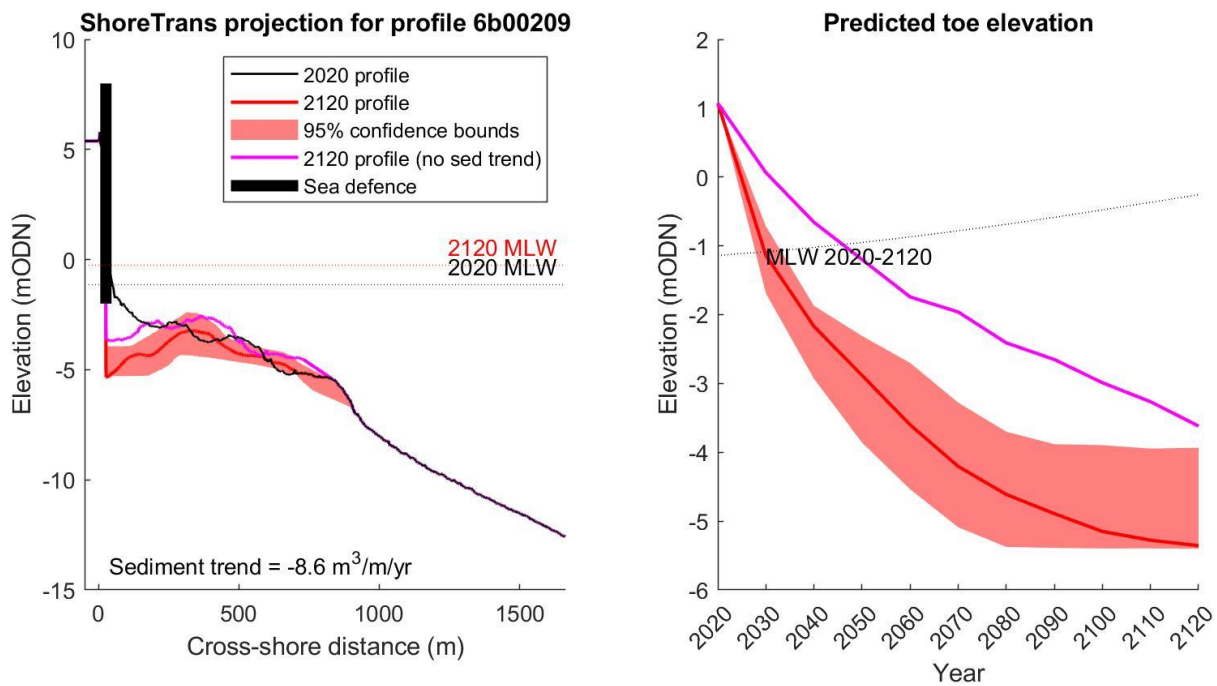

Figure 8-2. ShoreTrans results for profile 6b00209 on Teignmouth’s Seafront Beach (see Figure 4-1 for location). Left: predicted cross-sectional profile evolution between 2020 and 2120. Right: predicted beach elevation at the toe of the seawall over time. Results are shown with (red) and without (magenta) inclusion of existing sediment supply trends. Mean Low Water (MLW) elevation is shown for reference. The sea defence cross-shore position is indicated, but toe depth is unknown.

8.1.2 Point car park to Denn Spit

Unlike other areas of the Seafront Beach, the beach between Point Car Park and Teignmouth Spit is considerably more sheltered from wave action. This location is sheltered by both the Ness headland and the ebb tidal delta. Because of this sheltering, the depth of closure is assumed to be less than that of the exposed Seafront. The rate of retreat is dictated by the slope of the active profile, which for this area is treated in line with profiles inside the estuary (i.e. is taken between the beach crest and MLW; Section D.2.3).

Profile 6b00216 adjacent to Lower Point car park exhibits a near linear profile over the active profile zone (see Section D.2.3), which means the predicted Bruun Rule translation directly follows the existing slope, resulting in little change in profile shape with future SLR. Furthermore, due to the lack of energetic waves reaching this location, storm erosion demand and subsequent beach lowering at the seawall is not expected to be a significant factor in the future. Assuming simple Bruun Rule translation of the profile, and ignoring existing sediment supply trends, little profile change is predicted over the next 100 years at the beach at Lower Point car park in response to SLR (Figure D-17), but the toe elevation at the seawall may vary by up to 0.5 m from present day levels due to slight reshaping of the profile. However, the beach at Lower Point car park (represented by Profile 6b00216) has an increasing sediment volume trend of +4 m³/m/year. When this is factored in, ShoreTrans predicts that the beach

will prograde seawards and beach levels may increase from ~3 mODN to >3.5 mODN by 2120, assuming the existing sediment supply trends continue into the future.

Teignmouth Spit is the only area of Teignmouth’s frontage that doesn’t feature a seawall. It is modelled here as a simple barrier, where the crest elevation is assumed to maintain present-day freeboard as sea levels rise through natural overwashing processes, and the barrier is allowed to rollback with SLR. If existing sediment trends are ignored, and the barrier crest raises in line with SLR, ShoreTrans predicts that the spit may roll back ~20 m towards the estuary by 2120. However, profile 6b00216 immediately adjacent to the sand spit has seen sediment volume increase by +4 m³/m/year over the monitoring record. Applying this sediment trend to the spit, seaward barrier growth could easily outpace landward migration by 2120, as well as the spit potentially increasing in crest level (Figure D-18).

Future evolution of the spit will depend on various factors, including estuary dynamics, the rate of SLR, alongshore sediment supply, and the degree of exposure to waves. It should be noted that barrier dynamics are still poorly understood, and it is likely that changes in estuary flow and sediment dynamics (which have not been modelled in this study) will have a significant effect on the shape and size of Teignmouth spit into the future. This aside, the ShoreTrans predictions indicate that a usable subaerial beach will be maintained at Teignmouth Spit until at least 2120.

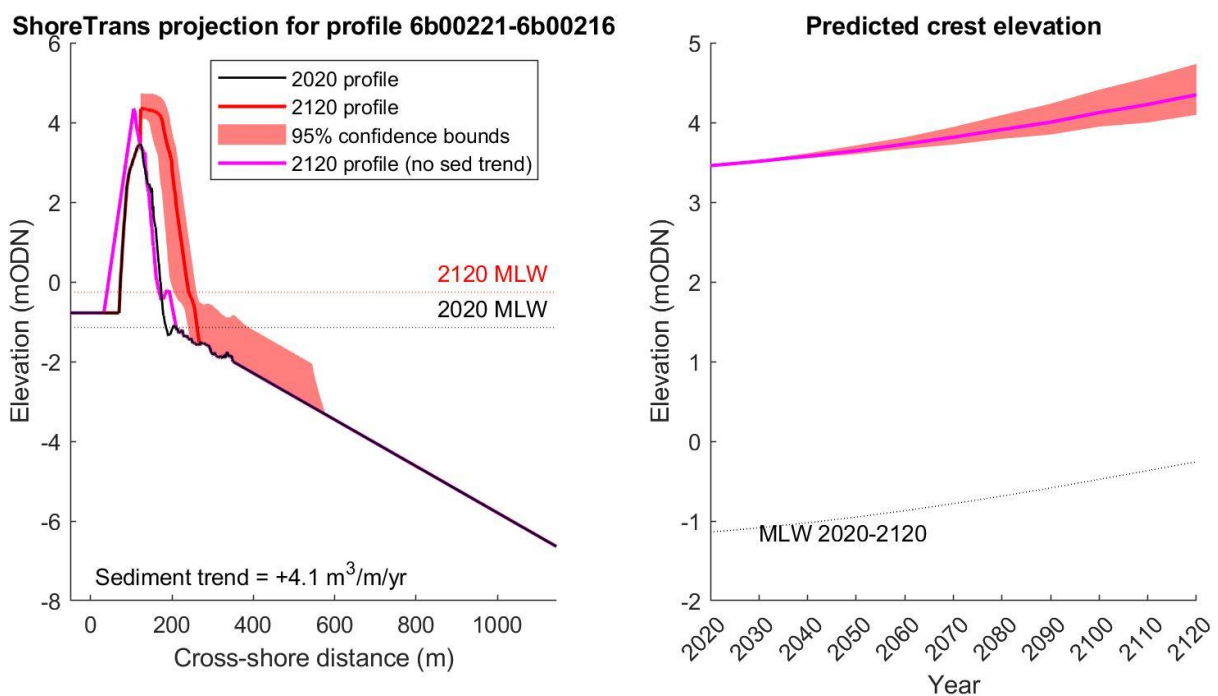

Figure 8-3. ShoreTrans results for Teignmouth Sand Spit (approximately between profiles 6b00221-6b00216; Figure 4-1 and Figure 4-2). Left: predicted cross-sectional profile evolution between 2020 and 2120. Right: predicted beach

elevation at the barrier crest over time. Results are shown with (red) and without (magenta) inclusion of existing sediment supply trends. Mean Low Water (MLW) elevation is shown for reference.

8.1.3 Teignmouth Back Beach

Beach evolution along Teignmouth Back Beach is primarily influenced by tides, low energy fetch-limited waves, and estuarine sediment supply. Possible effects of changing estuary dynamics on sedimentation have not been assessed in the present study, although observed trends in sediment volume are considered below.

Profiles on the Back Beach exhibit a near linear profile over the active profile zone (see Section D.2.3), which means the predicted Bruun Rule translation directly follows the existing slope, resulting in little change in profile shape with future SLR. Furthermore, due to the lack of energetic waves reaching the Back Beach, storm erosion demand and subsequent beach lowering at the seawall is not expected to be a significant factor in the future. Assuming simple Bruun Rule translation of the profile, and ignoring existing sediment supply trends, little profile change is predicted over the next 100 years at Teignmouth Back Beach in response to SLR (Figure D-20 and Figure D-19). However, the toe elevation at the seawall may vary by up to 1 m from present day levels on Teignmouth Back Beach due to slight reshaping of the profile (for example, Figure D-19).

However, profile 6b00228 between Fish Quay and Morgans Quay has experienced an increasing sediment supply trend over the last 15 years (+0.43 m³/m/year) and if this trend continues, ShoreTrans predicts an increase in beach levels of up to 0.5 m by 2120 from present day levels. Conversely, profile 6b00224 has seen a decreasing sediment supply trend (-0.24 m³/m/year) and could see a lowering of beach levels of around 0.5 m by 2120 from present day levels (Figure 8-4). Regardless of this, beach levels on Teignmouth's Back Beach are predicted to stay well above MLW over the next century, whether existing sediment supply trends are considered or not, with toe elevations predicted to stay within +/- 1 m of present-day levels (~ 3 mODN) under the assumptions of ShoreTrans.

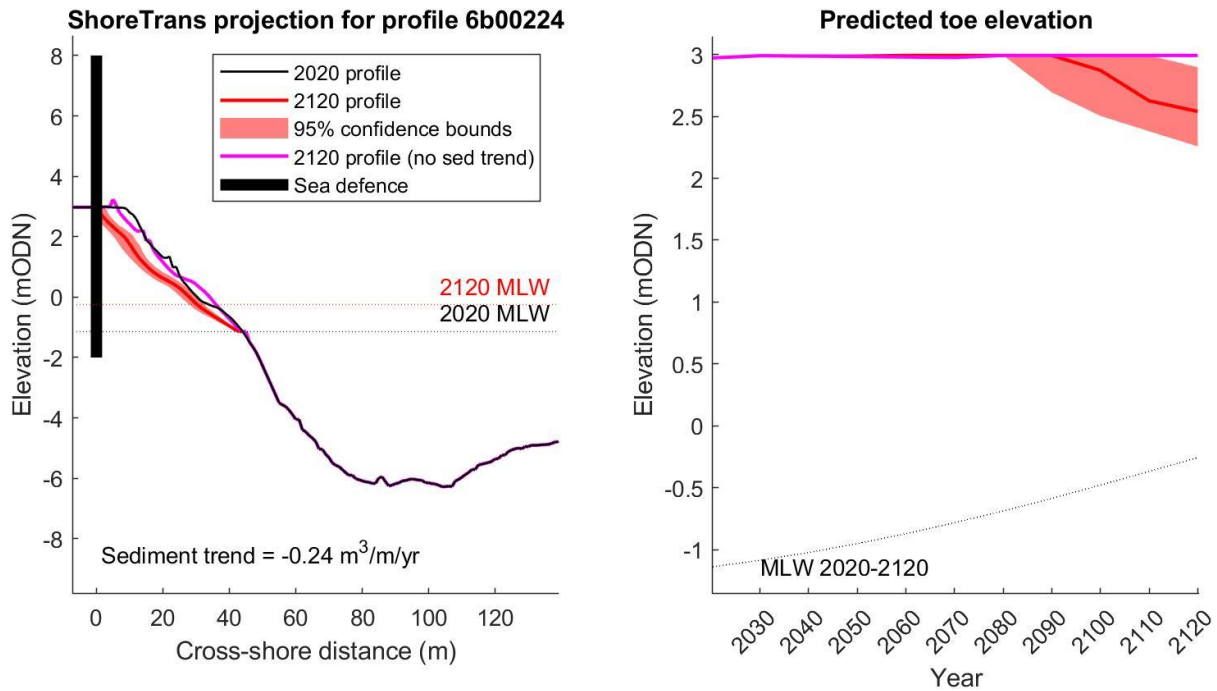

Figure 8-4. ShoreTrans results for profile 6b00224 on Teignmouth’s Back Beach (see Figure 4-2 for location). Left: predicted cross-sectional profile evolution between 2020 and 2120. Right: predicted beach elevation at the toe of the seawall over time. Results are shown with (red) and without (magenta) inclusion of existing sediment supply trends. Mean Low Water (MLW) elevation is shown for reference. The sea defence cross-shore position is indicated, but toe depth is unknown.

8.1.4 Shaldon Beach

Shaldon Beach sits adjacent to the estuary mouth and therefore sits partially inside and outside the estuary. As described in Section 8.1.2, previous modelling has demonstrated that the ebb shoal delta provides a high degree of shelter from storm waves to the areas in its lee. Furthermore, a lack of wave generated bedforms measured under such conditions has led previous studies to conclude that Shaldon Beach is not exposed to levels of wave energy sufficient to mobilise bed sediments (ABPmer, 2012b). Shaldon Beach is, however, in proximity to the fastest estuary flows occurring at Teignmouth, and its morphological evolution is likely to be strongly influenced by estuary dynamics in the future. The possible effects of changing estuary dynamics on sedimentation have not been assessed in the present study, although observed trends in sediment volume are considered below.

Here it is assumed that the morphology of Shaldon Beach is primarily influenced by tides and low-energy fetch-limited waves. The beach exhibits a near linear profile over the active profile zone (see Section D.2.3), which means the predicted Bruun Rule translation with future SLR directly follows the existing slope, resulting in little change in profile shape. Furthermore, due to the lack of energetic waves reaching Shaldon Beach, storm erosion demand and subsequent beach lowering at the seawall is not expected to be a significant factor in the future. Assuming simple Bruun Rule translation of the profile,

and ignoring existing sediment supply trends, the toe elevation at the seawall is predicted to change by <0.5 m with SLR to the year 2120. The exception to this is the eastern extent of Shaldon Beach (profile 6b00258), which has a more convex profile shape. Subsequently, the beach elevation at the seawall toe may drop by up to 1 m from present day levels due to reshaping of the profile as sea levels rise (**Figure D-23**).

Profiles 6b00254 and 6b00256 on the western side of Shaldon Beach have experienced an increasing sediment supply trend since 2011 (+0.5-1 m³/m/year) and if this trend continues, ShoreTrans predicts an increase in beach levels of up to 0.5 m by 2120 from present day levels (for example, Figure 8-5). Conversely, profile 6b00258 has seen a decreasing sediment supply trend since 2011 (-0.7 m³/m/year). This is predicted to exacerbate beach lowering at this location and could potentially lower the beach to the theoretical DoC by 2070 (Figure 8-6).

As such, beach levels at the western end of Shaldon Beach are predicted to stay well above MLW over the next century, whether existing sediment supply trends are considered or not, with toe elevations predicted to stay within +/- 1 m of present-day levels (3-3.5 mODN) under the assumptions of ShoreTrans. Conversely, beach levels at the eastern end of Shaldon Beach may drop below MLW by 2055-2080 if existing sediment supply trends continue.

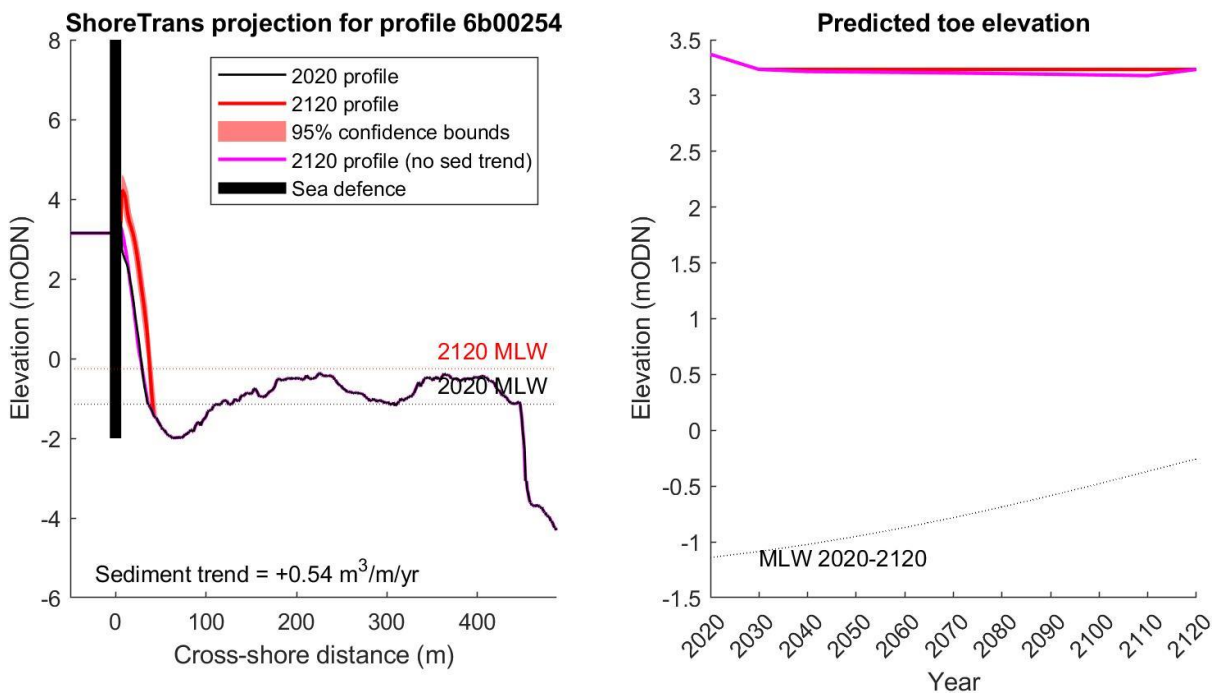

Figure 8-5. ShoreTrans results for profile 6b00254 on Shaldon Beach (see Figure 4-2 for location). Left: predicted cross-sectional profile evolution between 2020 and 2120. Right: predicted beach elevation at the toe of the seawall over time. Results are shown with (red) and without (magenta) inclusion of existing sediment supply trends. Mean

Low Water (MLW) elevation is shown for reference. The sea defence cross-shore position is indicated, but toe depth is unknown.

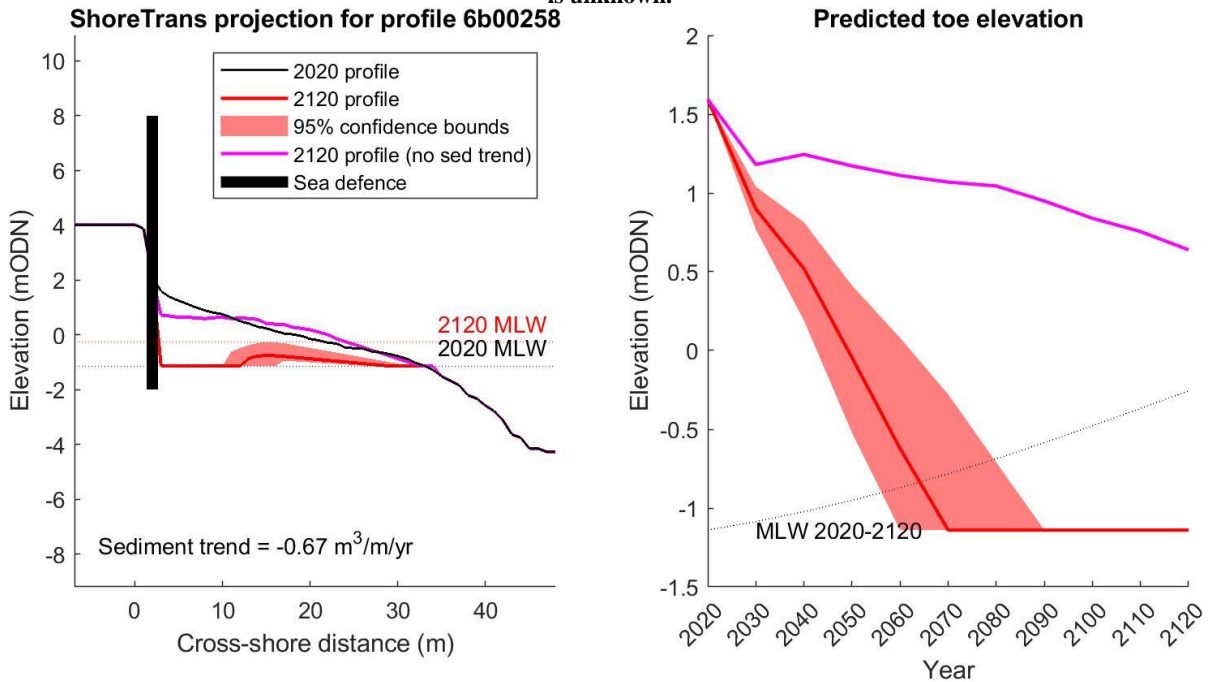

Figure 8-6. ShoreTrans results for profile 6b00258 on Shaldon Beach (see Figure 4-2 for location). **Left:** predicted cross-sectional profile evolution between 2020 and 2120. **Right:** predicted beach elevation at the toe of the seawall over time. Results are shown with (red) and without (magenta) inclusion of existing sediment supply trends. Mean Low Water (MLW) elevation is shown for reference. The sea defence cross-shore position is indicated, but toe depth is unknown.

8.2 Other considerations for future beach evolution

The ShoreTrans analysis in Section 8.1 assumes the projected profiles represent an equilibrium shape, and storm-recovery cycles in future would therefore cause temporary variation in beach level around this shape. Therefore, following periods of storm erosion, the beach levels may be temporarily lower than those projected here.

Possible increases in wave height into the future have not been considered. While potential changes in future storminess are expected to occur, current projections of future wave heights are uncertain and vary spatially around the UK. Environment Agency guidance is to account for a possible 10% increase in future wave height. However, this is not expected to alter the equilibrium beach profile to any significant degree, and therefore would not alter the ShoreTrans projections significantly.

Using 10 years of time varying waves to force an alongshore transport model, Stokes et al. (2019) predicted that net littoral drift rates north of Teignmouth Pier would reduce from around $45,000 \text{ m}^3/\text{year}$ at the year 2018 to $26,000 \text{ m}^3/\text{year}$ by 2115, under the UKCP18 RCP4.5 (95th percentile) SLR scenario, even with wave heights increased by 10% to account for potential future increases in storminess. This predicted reduction is caused by the shoreline migrating landwards, resulting in Sprey Point causing a

greater obstacle to littoral drift, especially under modest wave conditions. Therefore, it is possible that current sediment volume trends may change over the next 100 years, altering the degree of predicted beach lowering or progradation along the frontage.

Another consideration is the possibility of future changes in the contribution of easterly waves vs southerly waves, as easterly waves have diminishing in prevalence over the last 30 years (Section 7.4). How this balance will vary into the future is presently unknown, and as such the ShoreTrans analysis assumes that the balance of southerly and easterly waves will remain similar to present day over the next 100 years. More specifically, it assumes that observed trends in sediment volume at each studied profile will continue into the future, which is partly driven by the balance of southerly and easterly waves. Although beyond the scope of the present study, it is recommended that future modelling studies should investigate the sensitivity of future beach evolution to changes in the balance between southerly and easterly waves. Future increases in storm surge were also not considered, as they are not expected to significantly alter the dominant morphodynamic processes.

9 Hydro-morphodynamic Modelling for Engineering Options

Hydro-morphodynamic modelling using Delft3D-FM was conducted to evaluate various engineering options aimed at mitigating beach lowering. For this purpose, two Delft3D-FM modules, D-WAVE and D-FLOW, were coupled to simulate complex coastal processes. The D-WAVE module was employed to model wave propagation across the beach, while the D-FLOW module simulated hydrodynamic flow driven by the combined influences of river discharge, tides, and waves, as well as sediment transport processes and the associated changes in bed morphology. A detailed description of the numerical implementation of the D-WAVE and D-FLOW modules can be found in Deltares (2023a, 2023b), respectively. The model domain and initial setup used for this study were based on the hydro-morphodynamic simulations previously described in Appendix C, with adjustments made specifically to incorporate coastal protection structures into the simulations, thus allowing for an effective evaluation of their impacts.

9.1 Engineering scenarios

Two engineering scenarios were defined to evaluate coastal protection strategies, and their potential impacts on the hydro-morphodynamic conditions of the area were evaluated. These scenarios are as follows:

1. Reintroduction of a Timber Groyne Field along Teignmouth Seafront

In this scenario, the existing timber groynes along Teignmouth Seafront Beach frontage were reinstated at their original locations and dimensions. These groynes were represented in the model as fully non-permeable structures. The main objective was to determine whether reusing these groynes could effectively mitigate ongoing beach lowering.

2. Reintroduction of Timber Groynes with a Relocated Disposal Site

This scenario also involved reinstating the timber groynes with the same locations and dimensions as Scenario 1, but it introduced a modification by relocating the sediment disposal site. Instead of using the current disposal site at Sprey Points, dredged sediment was placed in the nearshore area south of the Pier, near Teignmouth Beach. Given the prevailing northward sediment transport patterns, the intention was to assess if the additional sediment from this offshore disposal site could be effectively transported toward the beach, thereby counteracting beach lowering.

The location of the modelled groyne field and the relocated disposal site within Scenario 2 are illustrated in Figure 9-1. For both scenarios, two groyne lengths, based on provided construction drawings, were incorporated into the simulations: long groynes of 67 m and short groynes of 36 m.

71 To refer to the work within this report, please cite as:
Coastal Marine Applied Research, 2025 Teignmouth Beach Management Plan: Coastal Processes Baseline Assessment. Report 2005_d1v3. University of Plymouth Enterprise Limited, 175 pp.

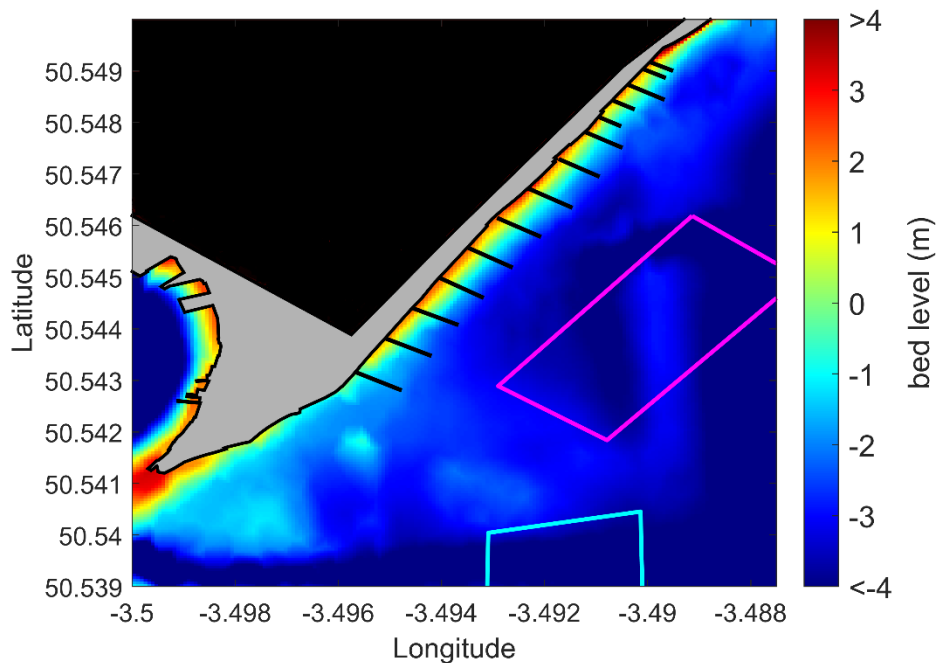

Figure 9-1. Initial bed along Teignmouth Beach overlaid by Groynes (black lines), dredging site (cyan box) and disposal site (magenta box) for Engineering Scenario 2.

9.2 Model grid

The model domain comprises three grids (illustrated in Figure C-2 of Appendix C). For wave simulations using the D-WAVE module, the two rectangular grids from the previous model configuration were retained. However, for the D-FLOW module, an additional refinement was introduced along Teignmouth Beach, achieving a finer mesh resolution of 5 meters. This enhanced resolution was essential to accurately capture the detailed hydro-morphodynamic responses of the beach due to the presence of the groynes.

9.3 Boundary conditions and model setups

The forcing conditions were based on the Multi-Annual Scenario, incorporating time-series data of wave height, wave period, wave direction, tidal variations, and river discharge rates from 14 May 2018 to 12 February 2020 as described in Section 5.3 and Section C.3. A morphological acceleration factor (MorFac) of 5 was applied, reducing the simulated time from 639 days to 50 days, thereby achieving a 92% reduction in computational time (see detailed description in Section C.5). To optimize computational efficiency, a wave forcing reduction method was applied, whereby waves with a significant height (H_s) smaller than 0.5 m were excluded from the simulations. The application of MorFac is described in Ranasinghe et al. (2011); Reyns et al. (2014).

The sediment size scenario followed the primary run (3 mm/1 mm run) as described in Section C.4, applying a D_{50} of 3 mm in the estuary and ebb-tidal delta and a D_{50} of 1 mm on the exposed frontage. This setup was based on the successful capture of flow velocities and observed morphodynamic patterns in previous non-groyne simulations (Appendix C), particularly those incorporating dredging activities.

A lower-estimate dredging-dumping scenario was defined, assuming 15,000 tonnes (24,323 m³) of sediment dredged per year (see Section 6.1 and 6.2). This estimate was derived from previous sediment recharge studies conducted for Teignmouth (ABPmer, 2012a). The model removes the volume gradually throughout the simulation, which is a simplification of the sporadic removal that occurs in real situation.

9.4 Hydrodynamics

Bed-level changes at Teignmouth Beach are strongly influenced by the combined effects of river flow, tidal currents, and wave-induced currents, each playing a crucial role in determining the overall hydrodynamic conditions along the shoreline. With the reintroduction of the groyne field, these combined currents interact directly with the groyne structures, altering local flow patterns. Figure 9-2 presents velocity distributions and flow patterns during various tidal stages—(a) ebb tide, (b) flood tide, (c) low tide, and (d) high tide—under spring tide conditions, clearly illustrating how the groyne structures affect local hydrodynamics. The presence of non-permeable groynes disrupts alongshore currents, leading to the formation of localized circulatory flows, or vortices, between groynes. These vortices increase the relative importance of cross-shore currents compared to alongshore currents, marking a distinct shift from the multi-annual scenario without groynes (Figure 9-3). Such circulatory patterns are particularly pronounced during ebb (a) and flood (b) tides when combined tidal and wave-induced currents are strongest. Additionally, Figure 9-4 shows the time series of water levels and wave heights associated with the conditions depicted in Figure 9-2 and Figure 9-3, providing essential context for interpreting the observed velocity distributions and hydrodynamic patterns.

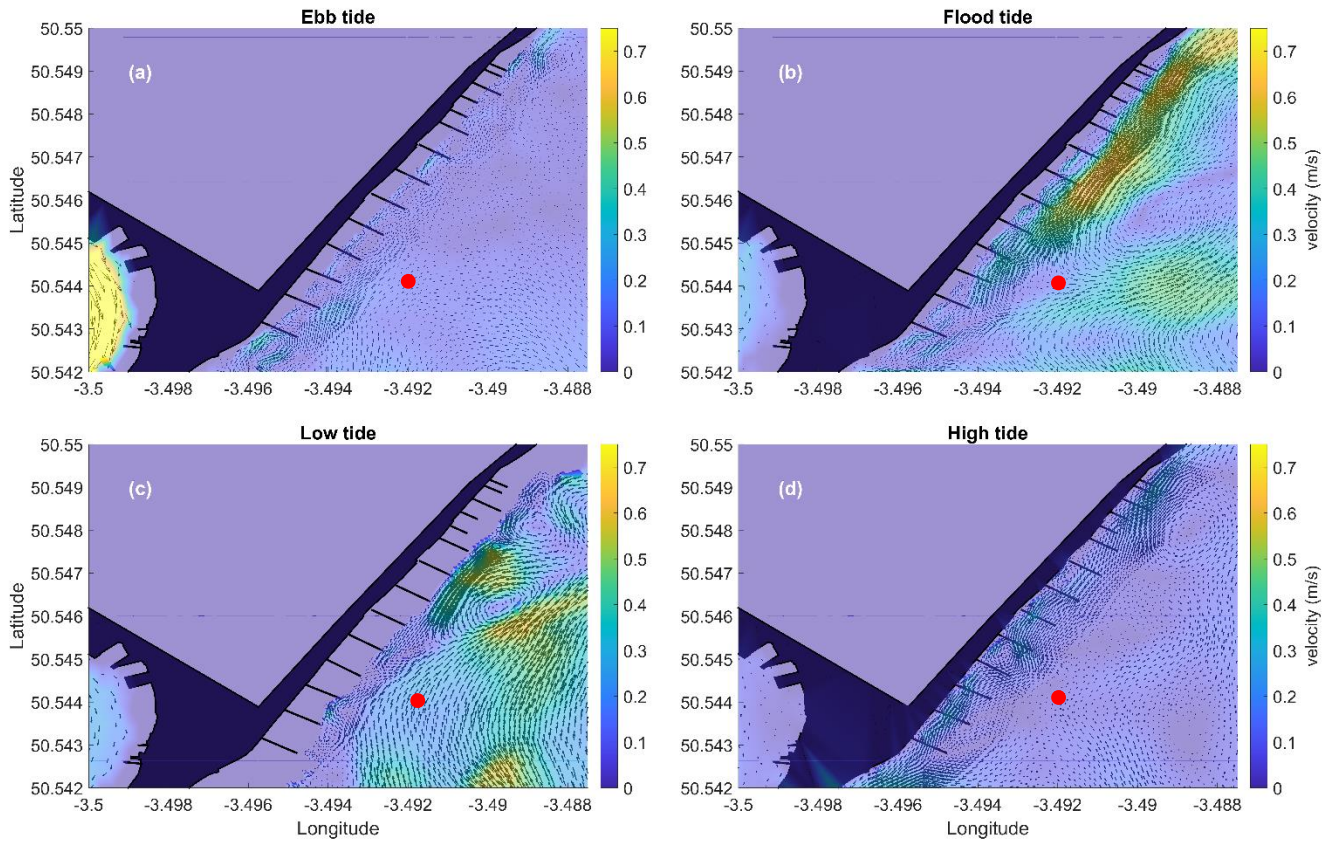

Figure 9-2. Flow velocity magnitude (colour scale, m/s) and direction (vector arrows) during spring tides under Engineering Scenario 1 at different tidal phases: (a) ebb tide, (b) flood tide, (c) low tide, and (d) high tide. Red markers indicate the location of the time series in Figure 9-4.

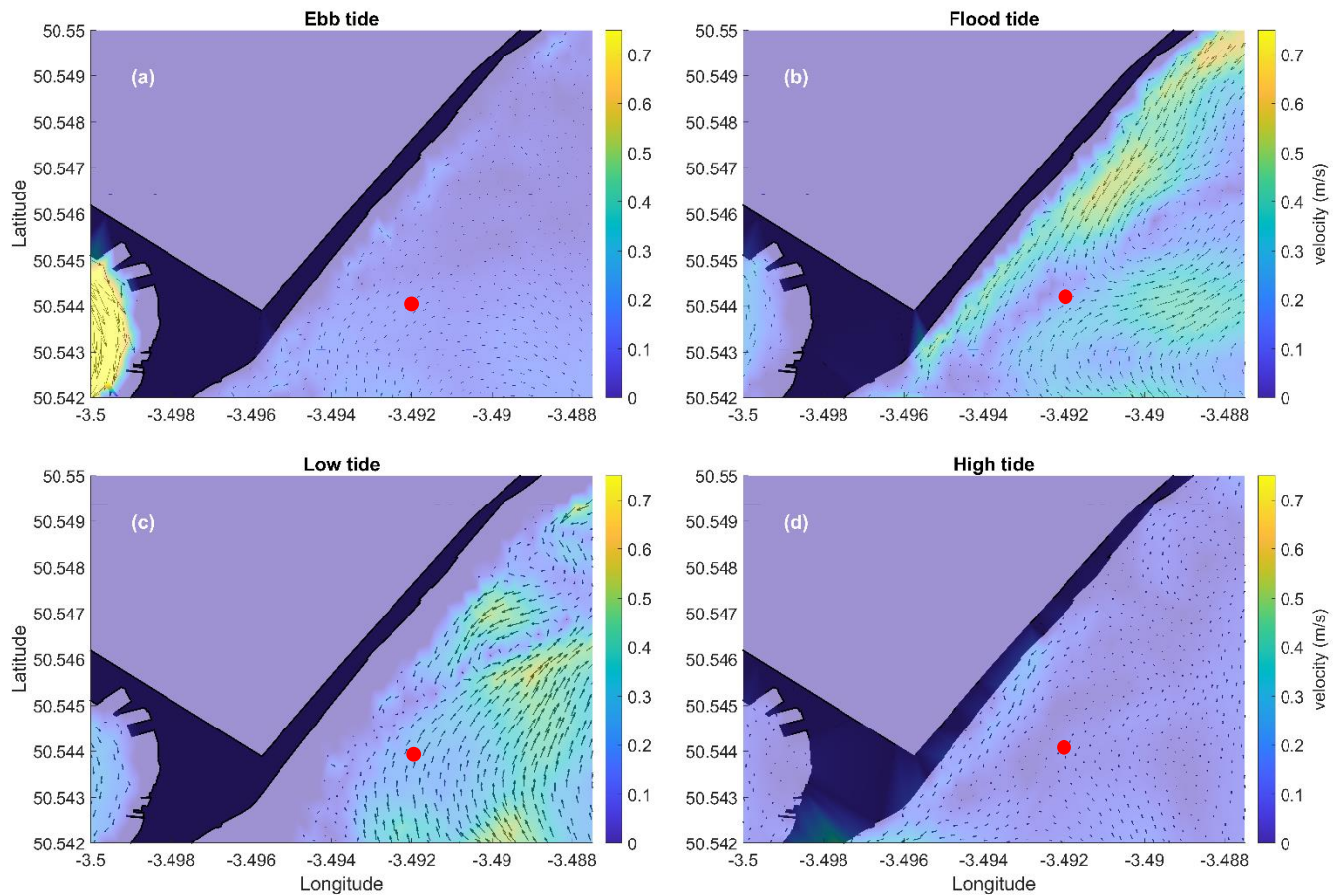

Figure 9-3. Flow velocity magnitude (colour scale, m/s) and direction (vector arrows) during spring tides under the Multi-annual Scenario without groynes at different tidal phases: (a) ebb tide, (b) flood tide, (c) low tide, and (d) high tide. Red markers indicate the location of the time series in Figure 9-4. See Appendix C for scenario settings.

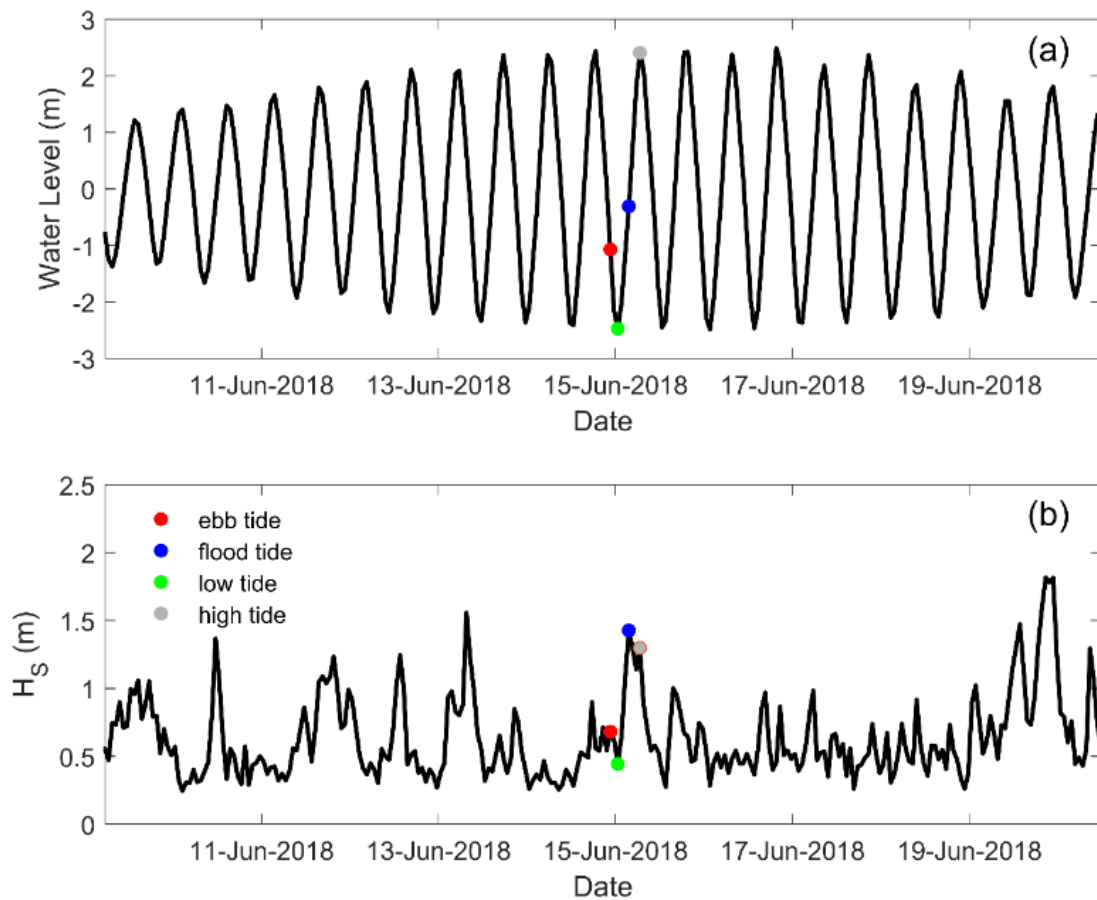

Figure 9-4. Time series of (a) water level (m) and (b) significant wave height (H_s , m) from 10 June to 19 June 2018. Coloured markers indicate specific tidal phases: ebb tide (red), flood tide (blue), low tide (green), and high tide (gray), corresponding to the observed times in Figure 9-2 and Figure 9-3.

9.5 Implications of Engineering Options for Bed Level Dynamics

Figure 9-5c–f illustrates the spatial extent of sediment redistribution resulting from groyne-induced changes in hydrodynamics. In both engineering scenarios, groynes reduce alongshore sediment transport, leading to sediment accumulation at their seaward ends. However, circulatory flows that enhance cross-shore currents cause erosion near the seawall at the landward ends of the groynes (Figure 9-5c, Figure 9-5d). The comparative analysis shown in Figure 9-5e, and Figure 9-5f emphasize this impact by highlighting bed level changes relative to the multi-annual scenario without groynes. Enhanced sediment accretion at groyne tips is accompanied by increased beach lowering for about 18% along the seawall (Table 9-1). These observations indicate that intensified flow confinement and circulatory patterns amplify erosion in these areas. Conversely, the comparatively limited beach lowering observed between shorter groynes suggests that adjusting groyne dimensions or permeability could help maintain greater alongshore transport, thus mitigating unintended erosion impacts.

Model results indicate small contribution of sediment transport from the relocated disposal area to the beach (Table 9-1). As demonstrated in Figure 9-5f, the dredged sediment placed offshore (marked in magenta) largely remains confined within the disposal area, with limited redistribution towards the shoreline. This limited transport results from weak wave forcing conditions during the simulation period, which are insufficient to effectively mobilize and deliver sediment to the shoreline. Although disposed sediment does not naturally migrate to the beach, it may provide a valuable resource for targeted beach nourishment, particularly in severely eroded locations. The disposal site's proximity to the beach provides logistical advantages, making sediment nourishment operations more accessible and cost-effective. Direct placement of dredged material along the seawall could thus effectively enhance coastal resilience by replenishing eroded sediment and reducing further beach lowering.

The volume of dredged sediment available is sufficient to support beach nourishment efforts in areas experiencing erosion. Table 9-1 provides sediment volume loss along Teignmouth Beach (within the area outlined by the blue polygon in Figure 9-6) over the simulation period, indicating that approximately 70% of dredged sediment can feasibly be utilized for beach nourishment. Nonetheless, careful consideration of sediment type and suitability is essential to ensure compatibility with public beach nourishment standards. Consequently, requirements for sediment extraction licences should be assessed in detail.

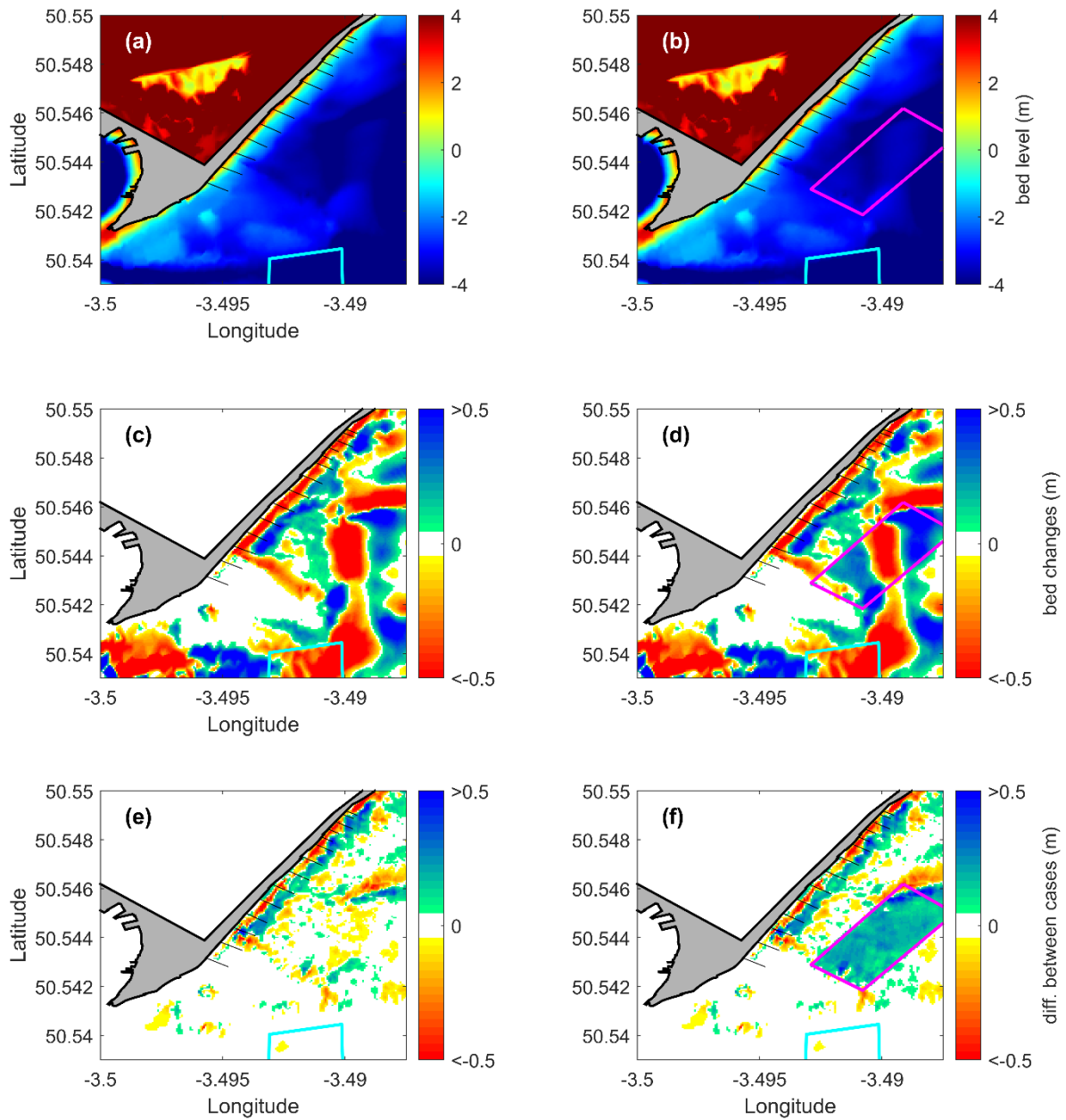

Figure 9-5. Spatial distribution of final bed levels (panels a, b), bed-level changes relative to initial conditions (panels c, d), and comparative analysis of bed-level differences between each Engineering Scenario and the baseline scenario without groynes (panels e, f). Positive values indicate increased sediment accretion, while negative values denote enhanced erosion. The left panels (a, c, e) represent Engineering Scenario 1 (groyne field reinstatement only), and the right panels (b, d, f) correspond to Engineering Scenario 2 (groyne reinstatement combined with relocated sediment disposal site). The magenta polygon outlines the relocated disposal area, and the cyan polygon indicates the existing dredging area.

Table 9-1. Calculated sediment volume loss along Teignmouth Beach for the baseline scenario without groynes and each engineering scenario, highlighting total erosion volume.

Scenario	Erosion Volume (m ³)
Baseline	14258
Scenario 1	16960
Scenario 2	16822

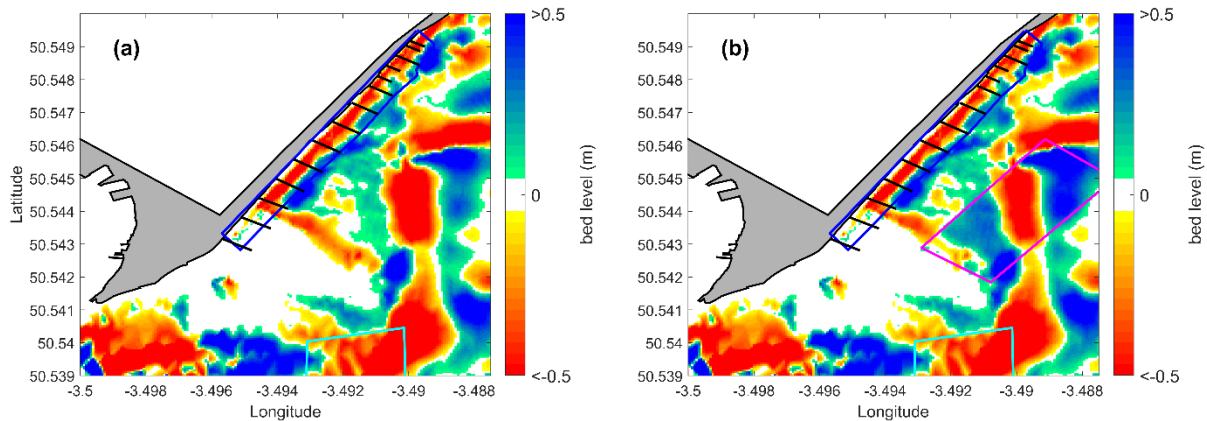

Figure 9-6. Spatial distribution of bed-level changes relative to initial conditions for (a) Engineering Scenario 1 (groyne field reinstatement only) and (b) Engineering Scenario 2 (groyne reinstatement with relocated sediment disposal site). Also shown are polygons outlining the area used to calculate sediment volume loss along Teignmouth Beach as shown in Table 9-1 (blue polygon), the proposed relocated disposal site (magenta polygon), and the existing dredging site (cyan polygon).

10 Denn Spit Dynamics

Following the first draft of this report Teignmouth District Council and the Environment Agency, who are undertaking further engineering works in Teignmouth, identified a wider interest in the role of the breakwater which extends across Denn Spit. To support this interest a small XBeach modelling study was commissioned and undertaken alongside the BMP Engineering Options phase of the study.

The Denn Spit report is a standalone piece of modelling and is included as a supplementary report in Appendix E. By way of a summary the report presents the XBeach modelling results of four scenarios: Southerly and Easterly storms, Storm Ciarán and an Extreme Storm event, each with and without the point breakwater in place.

Across all scenarios, the following points summarise the results:

- The point breakwater provides protection against erosion, at the location of the wall, particularly during easterly storm conditions.
- The effect of the point breakwater varies spatially and is dependent on storm direction, with easterly storms showing more uniform protection across the spit, while southerly storms exhibit more complex patterns of differential erosion and accretion.
- Under an extreme event significant rollback of the point is observed, although this is limited with the breakwater in place.

It is important to emphasise that these results are based on short-duration storm impact runs, which present several important limitations:

- Sustained high-energy winter conditions or consecutive storms would likely amplify the erosion extent and depth significantly beyond what is shown in these single-event simulations.
- The cumulative effect of multiple storm events would introduce complex morphological feedback mechanisms not captured in these isolated simulations.
- These simulations do not account for the potential impacts of sea level rise, which would further exacerbate erosion patterns.
- For scenarios with the breakwater in place, the model does not consider potential structural integrity issues that could arise when the front of the structure is subjected to erosion during storms.

These limitations suggest that while the point breakwater demonstrates protective benefits in these simulations, the real-world effectiveness under prolonged or more severe conditions may differ from these findings.

11 Conclusions

11.1 Summary of existing coastal processes

Teignmouth's coastline is strongly influenced by the combined effects of both tidal and estuarine currents, and storm waves arriving from both southerly and easterly approaches. These hydrodynamic processes drive the complex circulation of the ebb-tidal delta sandbars, as well as influencing littoral drift patterns along the beach frontage and exchanges of sediment with the wider coastline to the south and north of the bounding headlands.

Storm waves arriving from the south or east direction drive opposing littoral drift directions on Teignmouth beach. However, easterly waves occur less frequently and have shorter periods and lower heights than waves arriving from the south. Based on 13.5 years of wave buoy data, easterly waves contribute only $\sim 1/3^{\text{rd}}$ of the total wave power, while southerly waves contribute $\sim 2/3^{\text{rd}}$. Littoral drift on Teignmouth Seafront beach therefore has a net south to north drift direction, driven by the dominant southerly wave approach.

Under southerly storm-threshold waves, the Delft3D modelling predicts net south to north sediment fluxes of up to 1,000 m³/day with erosion on the southern end of Teignmouth Seafront Beach and deposition at the northern end. Meanwhile, easterly storm-threshold waves transport sediment efficiently back towards the southern end of the frontage due to the shoreline being drift aligned to the dominant southerly wave approach, with Net fluxes of up to 3,000 m³/day.

During a typical year, 24,000 – 31,000 m³/year of sediment is predicted to bypass around the bounding headlands at the north and south of Teignmouth, respectively, when storm wave action and tidal flows mobilise sediment well beyond the theoretical Depth of Closure. Ignoring the existing dredging activities, the model predicts a modest net import of sediment from the wider coastline into the Teignmouth frontage of 7,000 m³/year, under typical conditions. This supports the notion that Teignmouth is not a closed sediment cell. The net positive sediment budget is likely to be negatively affected by the existing dredging activities however (addressed below) and may in future be affected by any changes in the balance of easterly and southerly storm waves.

The fluxes predicted in this study are sensitive to the sediment size used in the model, with higher and lower fluxes predicted when finer and coarser sediment is simulated. Exact fluxes are challenging to determine, given the spatial variability in sediment size at Teignmouth (varying by an order of magnitude). However, the comparison of predicted fluxes between different model simulations provides useful insights, for example in providing proportional changes in flux with and without the existing dredging regime, or between waves arriving from opposing directions. The proportional effects

reported, and order of magnitude of the fluxes (within the range of simulated sediment classes) are considered reliable for the purposes of the BMP.

A key concern addressed in this report is the observed beach lowering between Teignmouth Lighthouse and Teignmouth Pier, where the beach has lowered by ~3 m vertically and has lost up to 100 m³/m of intertidal sediment since 2007, at an estimated rate of -5.88 m³/m/year. While injections of sediment from shore welding of the ebb-tidal sandbars may act to temporarily mitigate these losses every 2-4 years, the statistically significant negative trend in beach volume over the last 17 years suggests that the sandbar circulation alone cannot be relied upon to maintain beach levels there. Likely contributing factors to this observed beach lowering have been identified in this report, including:

- A strong increase in the net south to north flux along the shoreline between Teignmouth Lighthouse and Teignmouth Pier.
- A likely divergence in alongshore transport direction between Denn Spit and Teignmouth Lighthouse from net northward (north of Teignmouth Lighthouse) to net southwards (south of Teignmouth Lighthouse).
- A 75% reduction in energetic wave conditions arriving from the east since the 1990s (linked to changes in NAO), which act to partially re-nourish the area of observed beach lowering at the southern end of the Seafront Beach. The degree to which this re-nourishment occurs is dictated by the frequency and magnitude of easterly storm waves, which are becoming increasingly rare.
- A predicted enhancement of sediment export to the wider coastline to the north of Holcombe Headland caused by the existing sediment grab/disposal regime. The maximum licenced grab dredging quantity and existing grab and disposal locations are predicted to change the net sediment budget at Teignmouth from a positive sediment budget (+7,000 m³/year) to a negative budget (-10,000 m³/year).

11.2 Evaluation of engineering options

Engineering options evaluated for mitigating beach lowering at Teignmouth Seafront included reinstating timber groynes and relocating the offshore sediment disposal site closer to the shoreline. Results indicated that reinstated timber groynes successfully trapped sediment at their seaward ends. However, they also intensified local circulatory currents, leading to increased erosion at the landward ends of the groynes, near the seawall. Thus, groynes demonstrated mixed impacts, both positively trapping sediment and negatively enhancing localized erosion.

The scenario involving relocation of the dredged sediment disposal site from Sprey Points to a nearshore location south of Teignmouth Pier showed limited natural sediment transport back to the shoreline due to relatively mild wave conditions during the period analysed. Nevertheless, the relocated disposal site

offers practical advantages as a source for direct beach nourishment interventions at erosion-sensitive locations.

Overall, the scenarios evaluated helped reduce sediment losses compared to conditions without intervention, yet did not entirely prevent ongoing beach lowering. These outcomes suggest a combined approach, potentially adjusting groyne dimensions or permeability and strategically using sediment from the relocated disposal site, may offer more effective coastal management.

11.3 Future evolution of Teignmouth's beaches

Over medium (months-years) to long (years-centuries) time scales, the evolution of Teignmouth's Seafront Beach is expected to depend, in part, on the net sediment balance. This is driven by inputs versus losses to alongshore and offshore regions. Alongshore losses depend on the occurrence of southerly versus easterly storms, with southerly storms, which tend to be stronger and more frequent, driving more material to the north than is returned southward under easterly storms. Additionally, the frequency of easterly storms has decreased over time, although it is presently unclear whether this trend will continue in future. Future beach behaviour will therefore depend on the occurrence and magnitude of southerly and easterly storms.

Even without changes in storminess, sea level rise is expected to lead to the progressive submergence of beaches, resulting a decrease in their width. This will be exacerbated by any existing beach lowering trends caused by alongshore sediment supply. Future beach evolution will be constrained by the presence of seawalls along the entire frontage, which are expected to exacerbate beach lowering, as well as other management activities such as the replacement or removal of the existing groyne field, and on the quantity and location of dredging activities. The future response may also depend upon sediment sources from cliffs outside the study frontage as well as possible changes to the dynamics of the Teign estuary.

Assuming the beach will naturally attempt to migrate upwards and landward as sea level rises (as per the Bruun Rule) and that existing beach volume trends continue over the coming decades, the following projections have been made:

- The northern half of the Seafront Beach may experience relatively modest beach lowering (0.5–1 m lower than present day) by 2120 and may prograde in places if existing positive trends in beach volume continue. This is expected to maintain a usable intertidal beach at most places in front of the trainline over the next century.
- The southern half of the Seafront Beach is expected to experience accelerated beach lowering in future from coastal squeeze, exacerbated by existing negative trends in beach volume. Beach levels at the seawall between Teignmouth Lighthouse and Teignmouth Pier may lower to -2 to

-5 m ODN by 2120, and the beach there may be submerged throughout the tide by 2030 to 2050. Conversely, the positive sediment trend at Denn Spit indicates that seaward barrier growth could outpace landward migration, as well as the spit potentially increasing in crest level as sea levels rise.

- Worst-case (5th percentile) projection of future beach levels indicates that Teignmouth's Seafront Beach may be submerged in most places throughout the tide by 2120, even where existing positive sediment supply trends have occurred.

Inside the estuary, the evolution of Teignmouth Back Beach and Shaldon Beach is expected to be governed by tides, low energy fetch-limited waves, and estuarine sediment supply. Assuming existing sediment trends continue in future, the following future projections have been made for the estuary beaches:

- Beach levels on Teignmouth Back Beach are expected to stay within +/- 1 m of present-day levels (~ 3 mODN), maintaining a usable intertidal beach over the next century.
- On Shaldon Beach, beach levels are predicted to stay within +/- 1 m of present-day levels at the western end (3-3.5 mODN), maintaining a usable intertidal beach over the next century, while beach level at the eastern end may drop below MLW by 2055-2080, meaning the intertidal beach there may become submerged.

It should be noted that possible changes in wave climate have not been accounted for in any of the future projections, as there is still uncertainty about whether the regional wave climate will become more or less energetic in future. Furthermore, it is not yet possible to reliably forecast whether the balance of easterly and southerly waves will alter in future, which may be equally or even more important than changes in storm magnitude to the overall sediment budget. Possible effects of changing estuary dynamics in future have also not been assessed in the present study.

11.4 Changes to existing understanding

SCOPAC (New Forest District Council, 2017) provides an invaluable synthesis of existing studies on the hydro- and morpho-dynamic characteristics of Teignmouth. However, a few notable alterations to SCOPAC's description of the coastal processes at Teignmouth can be concluded from the present study:

- Early analysis of the local wave climate had concluded that '*maximum energy waves approached from the east*' and that '*prevailing wave direction*' at Teignmouth was east-south-east. However, from an up-to-date analysis of 13.5 years of SWCMP wave buoy data at Dawlish it is clear that Atlantic waves arriving from the south feature larger storm wave heights, longer wave periods, and currently contribute ~2/3rd of the total alongshore oriented wave power.

Therefore, southerly waves originating from the Atlantic Ocean dominate the wave climate at Teignmouth, driving net northward littoral sediment fluxes along most of the Seafront Beach.

- SCOPAC (New Forest District Council, 2017) cites a 1970 study (Hydraulics Research Station, 1970) that concluded that waves from the south have little capacity for littoral transport south of Sprey Point, as they claim they are refracted towards shore normal by the ebb-shoal delta. SCOPAC therefore concludes that net transport south of Sprey Point is towards the south west. The modelling conducted for the present study, for the first time, includes estimates of annual net fluxes that account for both wave and estuary driven flow. This shows that the net transport direction is south to north along almost the entire Seafront Beach, albeit with a lower flux rate in the lee of the ebb-tidal delta and a higher rate further north. The previously believed flux divergence at Sprey Point (New Forest District Council, 2017) therefore does not exist. The present study provides some evidence that the divergence in flux direction actually occurs adjacent to Teignmouth Lighthouse, which is strongly corroborated by the fact that chronic beach erosion has occurred in that location over the last 15 years.
- It was previously thought that there was ‘*no evidence of any by-passing of Holcombe headland*’. However, the present modelling study suggests that significant volumes of sediment are able to bypass both Holcombe headland to the north and Ness Head headland to the south through the combined action of waves, tides, and estuary flow. This study therefore concludes that Teignmouth should not be considered a closed sediment cell (New Forest District Council, 2017), as significant exchanges of sediment are predicted with the wider coastline to the north and south when storm wave action and tidally induced flows mobilise sediment well beyond the theoretical DoC.

11.5 Recommendations for further work

A detailed model of the Teignmouth coastal system has been developed for this study, which will be used to investigate potential beach management options under the present BMP. Given the findings of the present study, it is anticipated that useful beach management options to simulate in the next modelling phase of this project might include:

- Implementation and refinement of a replenished groyne field, including variations in groyne configuration and permeability
- Revision of the current grab dredging regime, with particular focus on optimal dredge disposal site locations to enhance sediment retention and mitigate beach lowering
- Assessment of various beach nourishment methods utilizing sediment from nearshore disposal sites.

A number of potentially important aspects were either outside the scope of the present study or carry too many uncertainties to investigate at the present time. Therefore, it is recommended that future investigations may seek to answer the following questions:

- How will estuary dynamics change in future, and how will this alter the sediment budget?
- How will any future changes in nearshore wave climate – either from increased/decreased storminess or from increased depth at the coast due to SLR – affect sediment fluxes and coastal squeeze?
- How will Denn spit evolve in future, given possible changes in the frequency and magnitude of barrier overwashing, and potential changes in sediment flux on the estuary and seafront sides?
- How will the ebb- and flood-tidal deltas evolve in the future, give that changes in tidal prism and estuary flows may occur?
- What is the sediment depth above bed rock along the frontage?
- Where and when will beach lowering reach bed rock in future?
- How do variations in groyne configuration and permeability specifically affect sediment transport patterns and localized erosion?
- What are the long-term sustainability and performance outcomes of using relocated disposal sites as beach nourishment resources, considering sediment compatibility and logistical factors?

References

- ABPmer. (2002). *Teignmouth Quay Development Environmental Statement*. Retrieved from ABP Marine Environmental Research Ltd,:
- ABPmer. (2006). *Conceptual Understanding and Trial Dredge Assessment*. Retrieved from
- ABPmer. (2012a). *Teignmouth Recharge Scheme: Conceptual Understanding and Modelling Report*. Retrieved from
- ABPmer. (2012b). *Teignmouth Recharge Scheme: Conceptual Understanding and Modelling Report*. Retrieved from
- Aird, N. P. (2009). *Morphodynamics of ebb tidal delta sandbanks in a meso to macro tidal environment; Teignmouth, UK*. University of Plymouth,
- Ashton, A. D., Walkden, M. J., & Dickson, M. E. (2011). Equilibrium responses of cliffed coasts to changes in the rate of sea level rise. *MARINE GEOLOGY*, 284(1-4), 217-229.
- Atkinson, A. L., Baldock, T. E., Birrien, F., Callaghan, D. P., Nielsen, P., Beuzen, T., . . . Ranasinghe, R. (2018). Laboratory investigation of the Bruun Rule and beach response to sea level rise. *COASTAL ENGINEERING*, 136, 183-202.
- Bernardes, M. E. C. (2005). *Medium-term (months to years) morphodynamic modelling of a complex estuarine system*. University of Plymouth,
- Beuzen, T., Turner, I. L., Blenkinsopp, C. E., Atkinson, A., Flocard, F., & Baldock, T. E. (2018). Physical model study of beach profile evolution by sea level rise in the presence of seawalls. *COASTAL ENGINEERING*, 136, 172-182.
- Birkemeier, W. A. (1985). Field data on seaward limit of profile change. *Journal of Waterway, Port, Coastal, and Ocean Engineering*, 111(3), 598-602.
- Bruun, P. (1954). *Coast erosion and the development of beach profiles* (Vol. 44): US Beach Erosion Board.
- Bruun, P. (1962). Sea-level rise as a cause of shore erosion. *Journal of the Waterways and Harbors Division*, 88, 117-132.
- Bruun, P. (1988). The Bruun rule of erosion by sea-level rise: a discussion on large-scale two-and three-dimensional usages. *JOURNAL OF COASTAL RESEARCH*, 627-648.
- Caires, S. (2011). Extreme value analysis: wave data. *Joint WMO/IOC Technical Commission for Oceanography and Marine Meteorology (JCOMM) Technical Report(57)*, 33 pp.
- Capobianco, M., Larson, M., Nicholls, R. J., & Kraus, N. C. (1997). *Depth of closure: A contribution to the reconciliation of theory, practice, and evidence*. Paper presented at the Coastal Dynamics' 97.
- Castelle, B., Dodet, G., Masselink, G., & Scott, T. (2017). A new climate index controlling winter wave activity along the Atlantic coast of Europe: The West Europe Pressure Anomaly. *GEOPHYSICAL RESEARCH LETTERS*, 44, 1384-1392.
- Cooper, J. A. G., & Pilkey, O. H. (2004). Sea-level rise and shoreline retreat: time to abandon the Bruun Rule. *GLOBAL AND PLANETARY CHANGE*, 43, 157-171.
- Dean, R. G. (1986). Coastal armoring: effects, principles and mitigation. In *Coastal Engineering 1986* (pp. 1843-1857).
- Dean, R. G., & Houston, J. R. (2016). Determining shoreline response to sea level rise. *COASTAL ENGINEERING*, 114, 1-8.
- Deltares. (2014). *Delft3D-Flow user's manual: simulation of multi-dimensional hydrodynamic flows and transport phenomena, including sediments*. Retrieved from Deltares, Delft, The Netherlands.:
- Deltares. (2023a). *D-Flow Flexible Mesh User Manual*. The Netherlands: Deltares.
- Deltares. (2023b). *Delft3D-WAVE User Manual*. The Netherlands: Deltares.

- Dhoop, T., & Mason, T. (2018). Spatial Characteristics and Duration of Extreme Wave Events around the English Coastline. *Journal of Marine Science and Engineering*, 6(1), 14. Retrieved from <https://www.mdpi.com/2077-1312/6/1/14>
- Dorland, G. M. (1940). *Equilibrium sand slopes in front of sea walls*: University of California, Berkeley.
- Duvivier, P. (1998). *Management Plan for Lyme Bay and South Devon Coastline*, London.
- Fruergaard, M., Møller, I., Johannessen, P. N., Nielsen, L. H., Andersen, T. J., Nielsen, L., . . . Pejrup, M. (2015). Stratigraphy, evolution, and controls of a Holocene transgressive–regressive barrier island under changing sea level: Danish North Sea coast. *JOURNAL OF SEDIMENTARY RESEARCH*, 85(7), 820-844.
- Fruergaard, M., Sander, L., Goslin, J., & Andersen, T. J. (2021). Temporary late Holocene barrier-chain deterioration due to insufficient sediment availability, Wadden Sea, Denmark. *GEOLOGY*, 49(2), 162-167.
- Hallermeier, R. J. (1980). A profile zonation for seasonal sand beaches from wave climate. *COASTAL ENGINEERING*, 4, 253-277.
- Hamm, L., Mazas, F., Garcia, N., & Bailly, B. (2010). Assessment of extreme wave heights: an attempt to reconcile theory and practice. *European Journal of Environmental and Civil Engineering*, 14(2), 127-148.
- Hanson, H., & Kraus, N. C. (1989). *GENESIS: Generalized Model for Simulating Shoreline Change. Report 1. Technical Reference*.
- Hoekstra, P., Bell, P., van Santen, P., & Roode, N. (2001). *Intertidal Bedforms and Bedload Transport on Spratt Sand, Teignmouth (UK)*. Paper presented at the Coastal Dynamics' 01.
- Hoekstra, P., Bell, P., van Santen, P., Roode, N., Levoy, F., & Whitehouse, R. (2004). Bedform migration and bedload transport on an intertidal shoal. *CONTINENTAL SHELF RESEARCH*, 24(11), 1249-1269.
- Hydraulics Research Station. (1970). *Teignmouth Harbour Model Study to Investigate Improvements to the Harbour Entrance, and their influence on the neighbouring Beaches*. Retrieved from
- Jonathan, P., & Ewans, K. (2013). Statistical modelling of extreme ocean environments for marine design: a review. *OCEAN ENGINEERING*, 62, 91-109.
- Kinsela, M. A., Daley, M. J., & Cowell, P. J. (2016). Origins of Holocene coastal strandplains in Southeast Australia: Shoreface sand supply driven by disequilibrium morphology. *MARINE GEOLOGY*, 374, 14-30.
- Knaapen, M., & Joustra, R. (2012). Morphological acceleration factor: Usability, accuracy and run time reductions.
- Kraus, N. C., & McDougal, W. G. (1996). The effects of seawalls on the beach: Part I, an updated literature review. *JOURNAL OF COASTAL RESEARCH*, 691-701.
- Kriebel, D. L., Dally, W. R., & Dean, R. G. (1986). *Beach profile response following severe erosion events*: Coastal and Oceanographic Engineering Department, College of Engineering, University of Florida.
- Lesser, G. R., Roelvink, J. v., van Kester, J. T. M., & Stelling, G. (2004). Development and validation of a three-dimensional morphological model. *COASTAL ENGINEERING*, 51(8-9), 883-915.
- Luijendijk, A. P., de Schipper, M. A., & Ranasinghe, R. (2019). Morphodynamic acceleration techniques for multi-timescale predictions of complex sandy interventions. *Journal of marine science and engineering*, 7(3), 78.
- Luijendijk, A. P., Ranasinghe, R., de Schipper, M. A., Huisman, B. A., Swinkels, C. M., Walstra, D. J., & Stive, M. J. (2017). The initial morphological response of the Sand Engine: A process-based modelling study. *COASTAL ENGINEERING*, 119, 1-14.
- Masselink, G., Scott, T., Poate, T., Russell, P., Davidson, M., & Conley, D. (2016). The extreme 2013/2014 winter storms: hydrodynamic forcing and coastal response along the southwest coast of England. *Earth Surface Processes and Landforms*, 41, 378-391. doi:<https://doi.org/10.1002/esp.3836>

- McCarroll, R. J., Masselink, G., Valiente, N. G., Scott, T., Wiggins, M., Kirby, J.-A., & Davidson, M. (2021). A rules-based shoreface translation and sediment budgeting tool for estimating coastal change: ShoreTrans. *MARINE GEOLOGY*, 435, 106466.
- Miles, J. R., Russell, P. E., & Huntley, D. A. (2001). Field measurements of sediment dynamics in front of a seawall. *JOURNAL OF COASTAL RESEARCH*, 195-206.
- Morgan, J. A., Kumar, N., Horner-Devine, A. R., Ahrendt, S., Istanbuloglu, E., & Bandaragoda, C. (2020). The use of a morphological acceleration factor in the simulation of large-scale fluvial morphodynamics. *GEOMORPHOLOGY*, 356, 107088.
- New Forest District Council. (2017). *2012 update of Carter, D., Bray, M., & Hooke, J., 2004 SCOPAC Sediment Transport Study*, Bristol.
- Nicholls, R. J., Birkemeier, W. A., & Hallermeier, R. J. (1996). Application of the depth of closure concept. In *Coastal Engineering 1996* (pp. 3874-3887).
- Nunny, R. S. (1980). *A Study of Sediment Dynamics in a Shallow Estuary, River Teign, Devonshire*. (PhD Thesis). University of Exeter,
- Posford Duvivier. (1998). *Lyme Bay and South Devon Draft Shoreline Management Plan – Introduction; Volume I – Core Report, Volume II – Supporting Document*. Retrieved from
- Ranasinghe, R., Swinkels, C., Luijendijk, A., Roelvink, D., Bosboom, J., Stive, M., & Walstra, D. (2011). Morphodynamic upscaling with the MORFAC approach: Dependencies and sensitivities. *COASTAL ENGINEERING*, 58(8), 806-811.
- Ranasinghe, R., Swinkels, C., Luijendijk, A., Roelvink, D., Bosboom, J., Stive, M., & Walstra, D. (2011). Morphodynamic upscaling with the MORFAC approach: Dependencies and sensitivities. In (Vol. 58, pp. 806-811).
- Reyns, J., Dastgheib, A., Ranasinghe, R., Luijendijk, A., Walstra, D. J., & Roelvink, D. (2014). Morphodynamic upscaling with the MORFAC approach in tidal conditions: The critical MORFAC. In (Vol. 2014-Janua).
- Robinson, A. H. W. (1975). Cyclical Changes in Shoreline Development at the Entrance to Teignmouth Harbour, Devon, England. In J. Hails & A. Carr (Eds.), *Nearshore Sediment Dynamics and Sedimentation* (pp. 181-200). Chichester: John Wiley.
- Roelvink, J. (2006). Coastal morphodynamic evolution techniques. *COASTAL ENGINEERING*, 53(2-3), 277-287.
- Schwartz, M. L. (1967). The Bruun theory of sea-level rise as a cause of shore erosion. *The journal of Geology*, 75(1), 76-92.
- SCOPAC. (2004). *SCOPAC: Coastal Sediment Transport Study, Hope's Nose to Holcombe Point*. Retrieved from
- Scott, T., Masselink, G., O'Hare, T., Saulter, A., Poate, T., Russell, P., . . . Conley, D. (2016). The extreme 2013/2014 winter storms: Beach recovery along the southwest coast of England. *MARINE GEOLOGY*, 382, 224-241.
- Shore Protection Manual. (1984). Coastal Engineering Research Center. *US Army Corps of Engineers*.
- Siegle, E., Huntley, D. A., & Davidson, M. A. (2002). Modelling water surface topography at a complex inlet system—Teignmouth, UK. *JOURNAL OF COASTAL RESEARCH*(36), 675-685.
- Siegle, E., Huntley, D. A., & Davidson, M. A. (2007). Coupling video imaging and numerical modelling for the study of inlet morphodynamics. *MARINE GEOLOGY*, 236(3-4), 143-163.
- Silvester, R. (1977, 1977). *The role of wave reflection in coastal processes*.
- Soulsby, R. L., & Damgaard, J. S. (2005). *Bedload sediment transport in coastal waters*.
- Sprat, T. (1856). *An Investigation of the Movement of Teignmouth Bar*. Retrieved from London: privately published:
- Stevens, H. (2010). *Eshorance: an online methodology for estimating the response of estuarine shores from sea level rise*. Paper presented at the NSW Coastal Conference, 2010.

- Stokes, C., Poate, T., Masselink, G., & Davidson, M. (2019). *Parson's Tunnel to Teignmouth Coastal Desk Study*. Retrieved from
- Sutherland, J. (2001). *Synthesis of Teignmouth Coastal Area Modelling, in: COAST 3D, Final Volume of Summary Papers, Report TR 121, HR Wallingford, D5.1 to D5.5*. Retrieved from
- Sutherland, J., Walstra, D., Chesher, T., Van Rijn, L., & Southgate, H. (2004). Evaluation of coastal area modelling systems at an estuary mouth. *COASTAL ENGINEERING*, 51(2), 119-142.
- Sutherland, J., Waters, C., & Whitehouse, R. (2001). Continuous monitoring of tides, waves and currents at Teignmouth, UK (1998–1999). *HR Wallingford Report TR*, 116.
- Tait, J. F., & Griggs, G. B. (1991). *Beach response to the presence of a seawall; comparison of field observations*. Retrieved from
- Thompson, C. (2019). *The value of long-term, integrated monitoring to provide the evidence base for coastal management*. Paper presented at the Flood and Coast Conference, Telford.
- Tonkin & Taylor. (2017). *Coastal Hazard Assessment for Christchurch and Banks Peninsula. Prepared for Christchurch City Council*. Retrieved from
- Valiente, N. G., Masselink, G., Scott, T., Conley, D., & McCarroll, R. J. (2019). Role of waves and tides on depth of closure and potential for headland bypassing. *MARINE GEOLOGY*, 407, 60-75.
- Van Geer, P. F. C., de Vries, J. S. M. v. T., Boers, M., den Bieman, J. P., & McCall, R. T. (2014). Modelling Scour in Front of Dune Revetments in a Surf-Beat Model. *Coastal Engineering Proceedings*, 1(34), 43.
- Van Lancker, V., Lanckneus, J., Hearn, S., Hoekstra, P., Levoy, F., Miles, J., . . . Whitehouse, R. (2004). Coastal and nearshore morphology, bedforms and sediment transport pathways at Teignmouth (UK). *CONTINENTAL SHELF RESEARCH*, 24(11), 1171-1202.
- Van Rijn, L. C. (1993). *Principles of sediment transport in rivers, estuaries and coastal seas* (Vol. 1006): Aqua publications Amsterdam.
- Water Technology. (2022). *Victoria's Resilient Coast Coastal Hazards Extended Guideline. Report prepared for DELWP as part of the Victoria's Resilient Coast (VRC) program*. Retrieved from
- Water Technology. (2023). *Technical Methodology Report, Port Phillip Bay Coastal Erosion Hazards. Department of Energy, Environment and Climate Action*. Retrieved from
- Whitehouse, R., & Sutherland, J. (2001). COAST3D data report-3D experiment, Teignmouth, UK- Volume 1.
- Wiggins, M., Scott, T., Masselink, G., Russell, P., & McCarroll, R. J. (2019). Coastal embayment rotation: Response to extreme events and climate control, using full embayment surveys. *GEOLOGY*, 327, 385-403.
- Zhang, K., Douglas, B. C., & Leatherman, S. P. (2004). Global warming and coastal erosion. *CLIMATIC CHANGE*, 64, 41-58.

Appendix A Effects of seawalls on beaches

Apart from Denn Spit, the entire coastal frontage in Teignmouth is backed by engineered seawalls and consideration of the effects of such structures on present and future beach response is therefore important. The effects of a seawall on the surrounding beach morphology are shown in the scientific and engineering literature to be site-specific and vary depending on the environmental forcing conditions, the structure type, the relative position of the seawall on the beach, and the local availability of sediment (Kraus & McDougal, 1996; Tait & Griggs, 1991). The potential types of beach response are illustrated in Figure A-1.

Berm located seaward of seawall

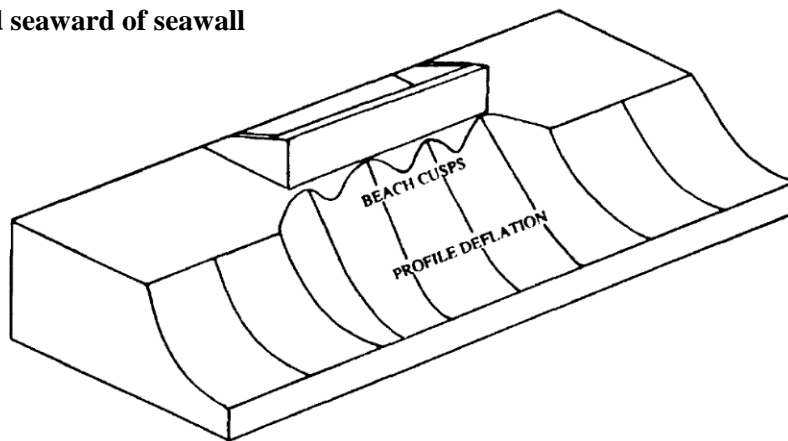

Berm located landward of seawall

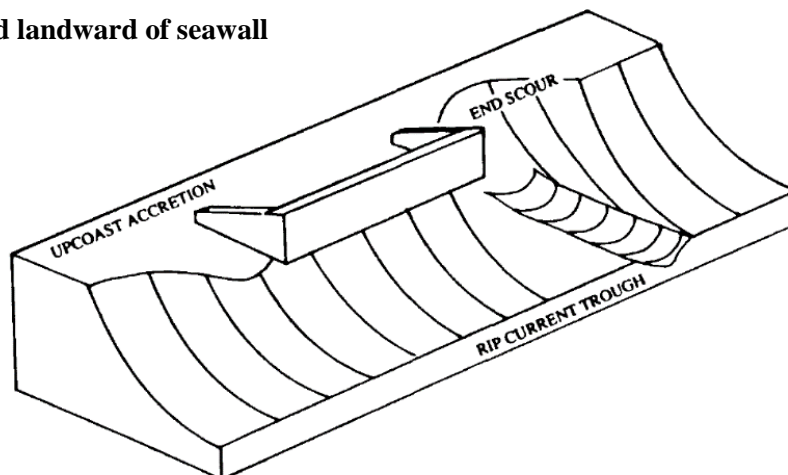

Figure A-1. Types of morphological response caused by the presence of a seawall, from Tait and Griggs (1991). Upper panel: response types with beach berm located seaward of the seawall. Lower panel: response types with beach berm located landward of the seawall.

It is thought that the presence of an engineered structure on a beach causes lowering of the beach profile in front of the structure by concentrating the wave dissipation processes over a shorter section of the

profile (Robert G. Dean, 1986; Kriebel, Dally, & Dean, 1986). The concept claims that the same total amount of sediment is stripped from the upper beach during a storm whether there is a seawall present or not (Figure A-2). Therefore, the sediment that would have been removed landward of the seawall, if the seawall were not present, is instead removed from the now truncated beach profile in front of the seawall (Robert G. Dean, 1986). Although this theory has not been extensively proven, it is well accepted that wave energy that is not dissipated on the beach must either dissipate at the wall through wave breaking and turbulence, or reflect from the wall (Van Geer, de Vries, Boers, den Bieman, & McCall, 2014).

A significant proportion of wave energy can be reflected back out to sea by the presence of a seawall or sloping revetment. The reflection of wave energy by the structure can cause sediment to be stirred, resulting in increased sediment suspension in front of the engineered structure, especially where a standing wave is generated (Dorland, 1940; Miles, Russell, & Huntley, 2001; Silvester, 1977). where suspended sediment is acted upon by a background current (tide or wave drive), sediment can be lost from the immediate area (Kraus & McDougal, 1996; Miles et al., 2001). For example, at a location where persistent shoreline recession is occurring due to an alongshore sediment transport gradient, wave reflection from a seawall can exacerbate erosion of the profile.

A field study was conducted in 2001 at the location of Sprey Point on Teignmouth beach, which measured the wave reflection and sediment flux, and compared them to the beach adjacent to Sprey Point, where the seawall was not influencing the hydrodynamics (Miles et al., 2001). This study found that reflection of the short waves was considerably higher at Sprey Point. Furthermore, they observed that the suspended sediment concentration in front of Sprey Point was up to three times larger than at the natural beach, the alongshore current was increased, and that onshore transport was inhibited (Miles et al., 2001).

Alongshore sediment transport, or littoral drift, occurs due to obliquely arriving waves driving an alongshore oriented current (i.e. parallel to the coast). The volume of sediment transported alongshore is known to be primarily a function of the sediment size, the wave energy, and the angle of wave incidence, with the greatest potential for alongshore transport occurring when waves are large and from a 45° angle to the shore (Shore Protection Manual, 1984). The blocking of alongshore sediment transport caused by a structure or headland results in a gradient in the alongshore sediment transport rate. Any headland, groyne, seawall or other obstacle to alongshore sediment transport is expected to cause sediment to accumulate up-drift of the obstacle, where the beach would widen, due to a decreasing transport gradient (Figure A-3). Conversely, sediment would be eroded down-drift of the structure, where the beach would narrow, due to an increasing transport gradient (Robert G. Dean, 1986; Shore Protection Manual, 1984).

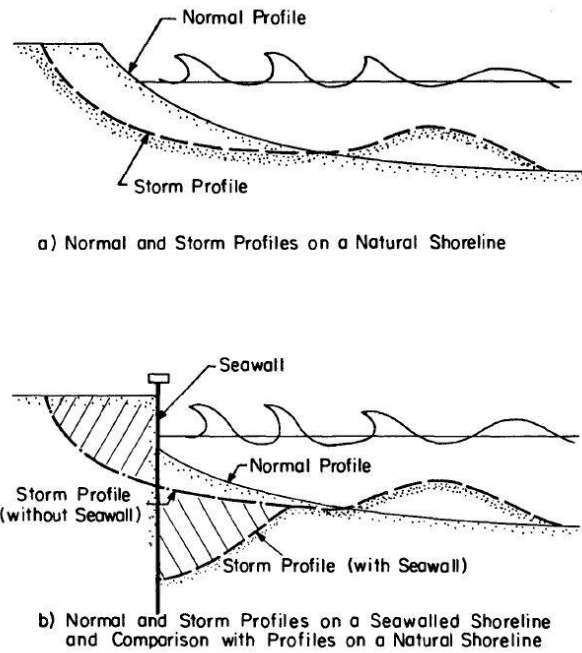

Figure A-2. Conceptual effect of a seawall on beach profile response to erosive wave conditions (from Robert G. Dean, 1986).

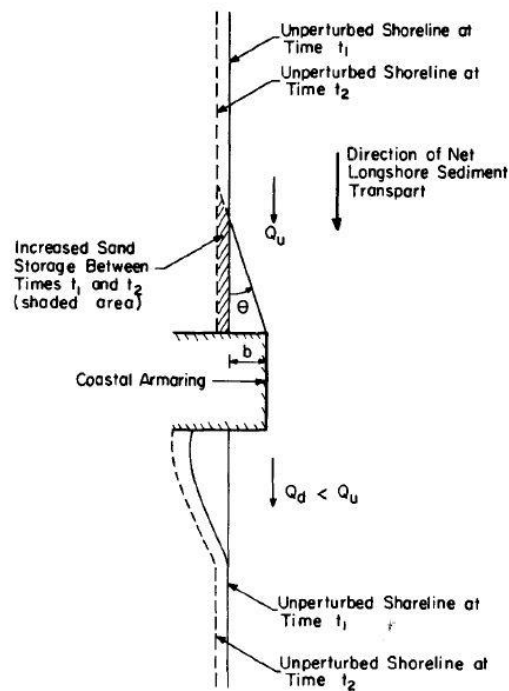

Figure A-3. Conceptual effect of a seawall on alongshore sediment transport and shoreline response (from Robert G. Dean, 1986).

The Bruun Rule (Bruun, 1954, 1962, 1988; Schwartz, 1967) is a concept that is widely used to predict the possible response of natural beaches to sea-level rise, and assumes that as water levels increase, wave conditions will remove material from the upper beach profile and redistribute it to the lower part of the beach, causing the equilibrium profile shape to translate upward and landward in response to sea-level rise (Figure A-4). The Bruun Rule assumes that the ratio of sea level rise to shoreline retreat is equal to the shoreface slope from an upper beach location (the berm or dune) to an offshore ‘depth of closure’ (DoC), representing the point at which cross-shore sediment transport reduces to zero. The geometric model is given by: $R = S \cdot L / (H_d + H_f)$ where, R is the predicted retreat distance, S is the rise in mean sea level, L is the width of the active profile, H_d is the depth of closure, and H_f is the foredune height. This concept has been debated widely in the scientific literature, with some arguing that it should be abandoned as it oversimplifies most real beaches (Cooper & Pilkey, 2004), while others have presented scaled model tests that provide evidence to support it (Atkinson et al., 2018; Schwartz, 1967).

Where a sea defence structure truncates a beach profile (i.e. exists within the surf-zone at least part of the time), as is the case with the seawalls at Teignmouth, the shoreline’s capacity to recede upwards and landward in response to sea-level rise is constrained. Scaled physical model tests have demonstrated that a natural beach profile translates upward and landward as expected in response to rising sea levels, maintaining equilibrium shape, but the presence of a sea defence structure increasingly changes the shape of the equilibrium profile as water levels rise (Atkinson et al., 2018; Beuzen et al., 2018).

(Atkinson et al., 2018; Beuzen et al., 2018). In agreement with the concept proposed by Robert G. Dean (1986) shown in Figure A-2, Beuzen et al. (2018) demonstrated that as sea-level increases, an increasing volume of erosion is denied by the presence of a sea defence structure, which is satisfied by the removal of sediment in front of the sea defence, unnaturally lowering the beach profile (Figure A-5).

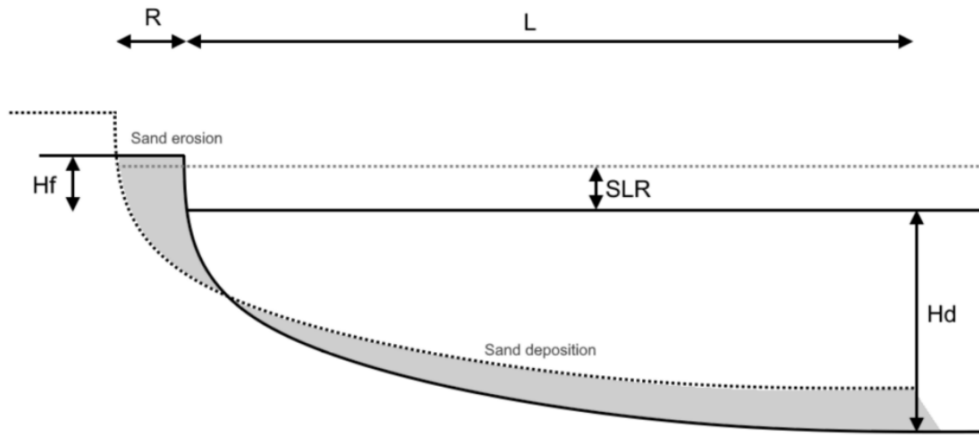

Figure A-4. Conceptual schematic of the Bruun Rule of beach profile translation under sea level rise (Water Technology, 2023). R is the predicted retreat distance, SLR is the rise in mean sea level, L is the width of the active profile, Hd is the depth of closure, and Hf is the foredune height.

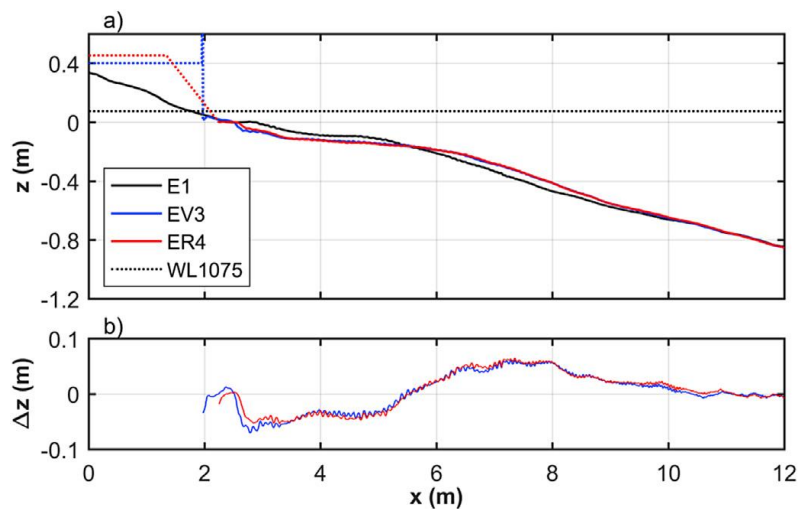

Figure A-5. Physical model results (scale 1:10) from Beuzen et al. (2018) showing beach profile response to rising sea levels. Upper panel: Natural equilibrium beach profile (solid black line, ‘E1’) compared to equilibrium profiles for beaches featuring a vertical impermeable seawall (dotted blue line, ‘EV3’), or a permeable rock revetment (dotted red line, ‘ER4’) subjected to erosive wave conditions and 75 cm of sea-level rise (prototype scale, ‘WL 1075’). Lower panel: Elevation difference between the natural beach profile and the two engineered beach profiles – the two structure types elicit an almost identical profile response.

Appendix B Statistical analysis of beach profile changes

Measured beach profile data were used to analyse the intertidal variations and volumetric changes over time for 15 profiles along Teignmouth’s Seafront Beach (Figure 4-1.), as well as 3 profiles on Teignmouth Back Beach and 3 profiles on Shaldon Beach (Figure 4-2.). The intertidal volume was calculated for each profile by computing the volume above Mean Low Water Springs (MLWS = -1.95 m ODN) and seaward of the top of the profile or seawall. Some surveys did not extend fully to MLWS depth, in which case the profile was linearly extrapolated to make comparable estimates of profile volume.

Table B-1, Table B-2, and Table B-3 show net volumetric changes at each SWCMP interim profile studied, as well as linear trends fitted to the volumetric timeseries. Most of the profiles exhibited a statistically significant linear trend (p-value <0.05). However, for three of the profiles the volume changes did not follow a linear pattern, and an average rate of change was computed instead using the volume change between the first and last surveyed profile, divided by the number of years of the timeseries. The profile measurements used to generate the volumes and trends are presented in Figure B-1 to Figure B-20.

Table B-1. Net volume changes and trends at each SWCMP interim profile along Teignmouth Seafront Beach. Trends highlighted in bold show the values used in the study, consisting of either a linear fit to the data (p-value <0.05) or the average measured change per year where the linear fit was not statistically significant.

PCO profile number	Trend, linear 2007-2023 m ³ /m/year (p-value)	Trend, average 2007-2023 m ³ /m/year	Net change 2007-2023 m ³ /m	Net change 2007-2013 m ³ /m	Net change 2013-2014 m ³ /m	Net change 2014-2023 m ³ /m
'6b00153'	1.71 (0.00)	1.14	18.38	1.72	20.04	-3.37
'6b00157'	2.64 (0.00)	2.53	40.93	-2.28	11.91	31.30
'6b00161'	1.74 (0.00)	2.96	47.88	-8.97	2.19	54.65
'6b00165'	2.16 (0.00)	3.26	52.72	6.11	-13.88	60.49
'6b00169'	1.02 (0.02)	2.02	32.63	19.08	-17.23	30.78
'6b00172'	1.13 (0.02)	2.22	35.97	23.48	-5.48	17.97
'6b00179'	7.25 (0.00)	3.75	60.59	-3.79	-5.50	69.88
'6b00183'	8.71 (0.00)	7.81	126.32	-9.48	16.93	118.87
'6b00187'	2.15 (0.00)	2.69	43.42	-0.01	2.91	40.53
'6b00191'	2.11 (0.00)	2.97	47.84	-1.36	-1.98	51.17
'6b00198'	-0.27 (0.29)	-0.46	-7.48	-17.14	13.17	-3.50
'6b00204'	-4.13 (0.00)	-2.91	-46.95	-34.05	2.62	-15.51
'6b00209'	-8.55 (0.00)	-6.05	-97.61	-20.86	36.20	-112.94
'6b00212'	-1.54 (0.37)	-3.90	-62.97	-42.12	5.09	-25.94
'6b00216'	4.14 (0.02)	0.99	16.05	-48.29	46.55	17.78

Table B-2. Net volume changes and trends at each SWCMP interim profile along Teignmouth Back Beach. Trends highlighted in bold show the values used in the study, consisting of either a linear fit to the data (p-value <0.05) or the average measured change per year where the linear fit was not statistically significant.

PCO profile number	Trend, linear 2007-2023 m ³ /m/year (p-value)	Trend, average 2007-2023 m ³ /m/year	Net change 2007-2023 m ³ /m	Net change 2007-2013 m ³ /m	Net change 2013-2014 m ³ /m	Net change 2014-2023 m ³ /m
'6b00228'	0.43 (0.00)	0.39	6.31	2.95	0.62	2.74
'6b00224'	-0.01 (0.94)	-0.24	-3.94	-15.72	15.29	-3.52
'6b00221'	2.44 (0.00)	2.44	39.36	5.42	31.44	2.50

Table B-3. Net volume changes and trends at each SWCMP interim profile along Shaldon Beach. Trends highlighted in bold show the values used in the study, consisting of either a linear fit to the data (p-value <0.05) or the average measured change per year where the linear fit was not statistically significant.

PCO profile number	Trend, linear 2007-2023 m ³ /m/year (p-value)	Trend, average 2007-2023 m ³ /m/year	Net change 2007-2023 m ³ /m	Net change 2007-2013 m ³ /m	Net change 2013-2014 m ³ /m	Net change 2014-2023 m ³ /m
'6b00258'	-0.67 (0.04)	-0.41	-4.74	-1.83	8.36	-11.27
'6b00256'	0.91 (0.00)	0.73	8.41	-2.67	3.53	7.55
'6b00254'	0.54 (0.00)	0.77	8.88	-2.93	4.88	6.93

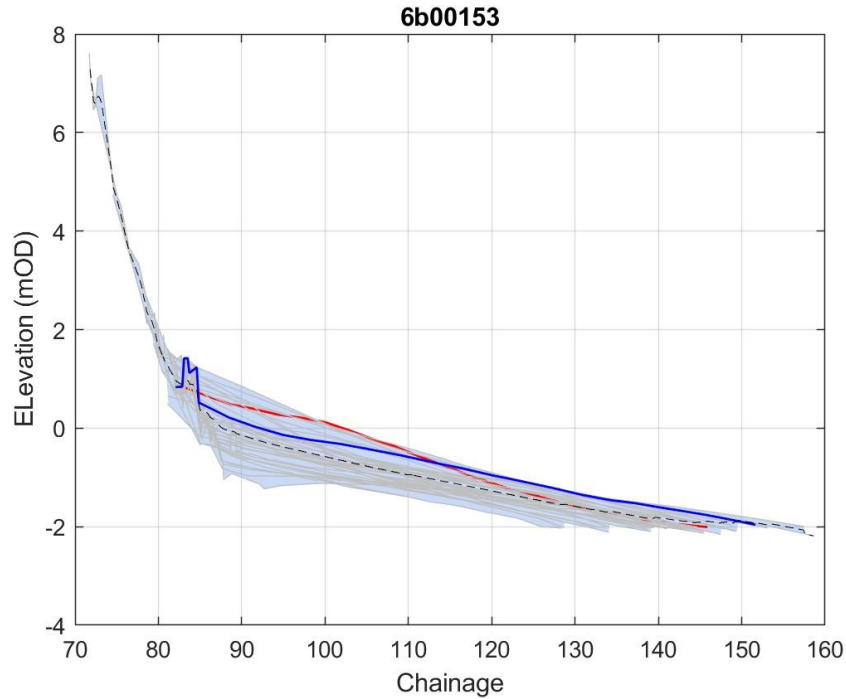

Figure B-1. Profile envelope (blue shading) for all data for the period 2007 – 2023 at SWCMP profile 6b00153. Individual profile observations are plotted in grey and the mean elevation is indicated by a dashed line. Blue line signifies the most recent profile from 2023 and a red line indicates the initial profile from 2007. The location of this profile is shown in Figure 4-1.

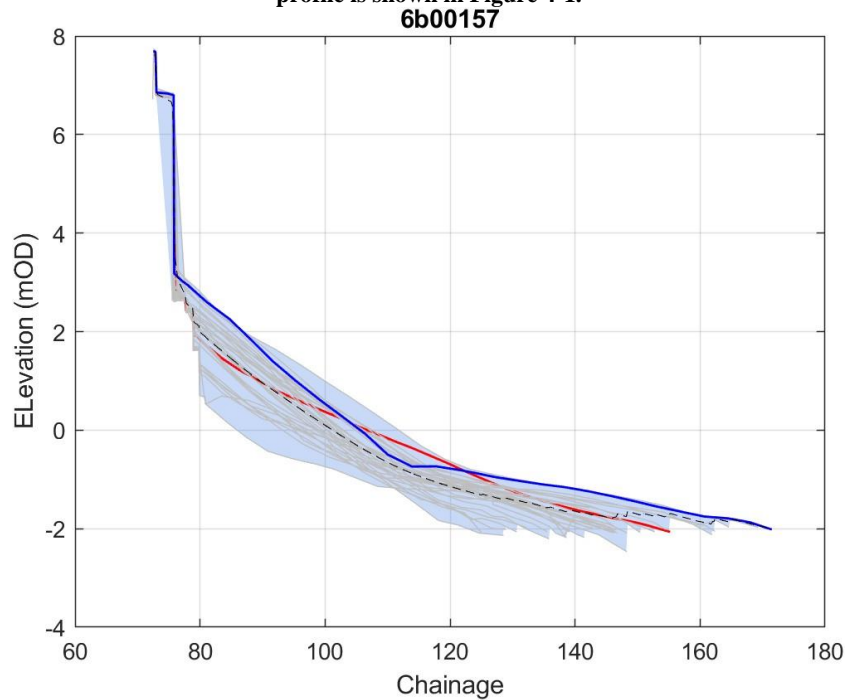

Figure B-2. Profile envelope (blue shading) for all data for the period 2007 – 2023 at SWCMP profile 6b00157. Individual profile observations are plotted in grey and the mean elevation is indicated by a dashed line. Blue line signifies the most recent profile from 2023 and a red line indicates the initial profile from 2007. The location of this profile is shown in Figure 4-1.

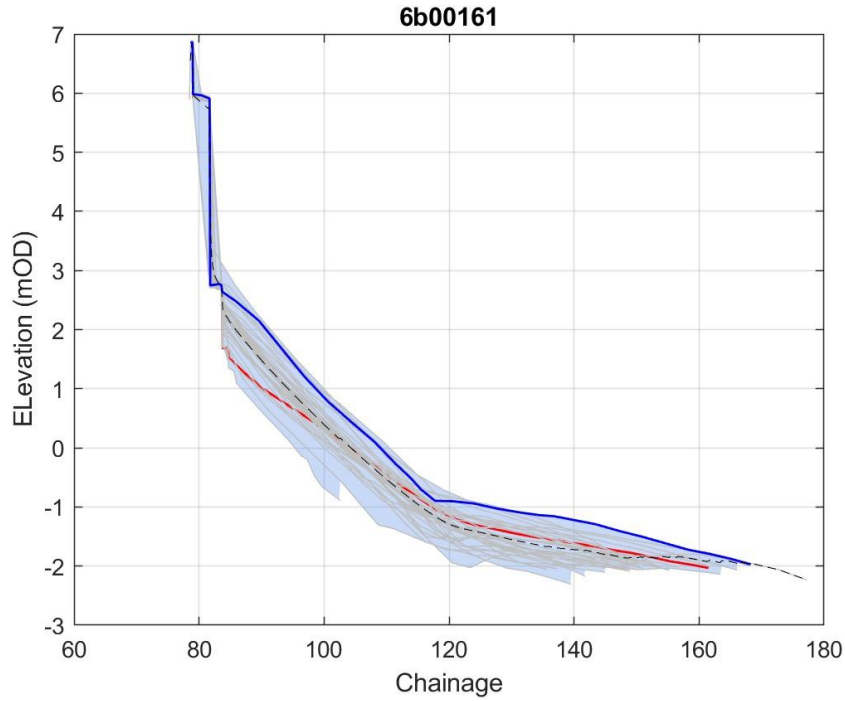

Figure B-3. Profile envelope (blue shading) for all data for the period 2007 – 2023 at SWCMP profile 6b00161. Individual profile observations are plotted in grey and the mean elevation is indicated by a dashed line. Blue line signifies the most recent profile from 2023 and a red line indicates the initial profile from 2007. The location of this profile is shown in Figure 4-1.

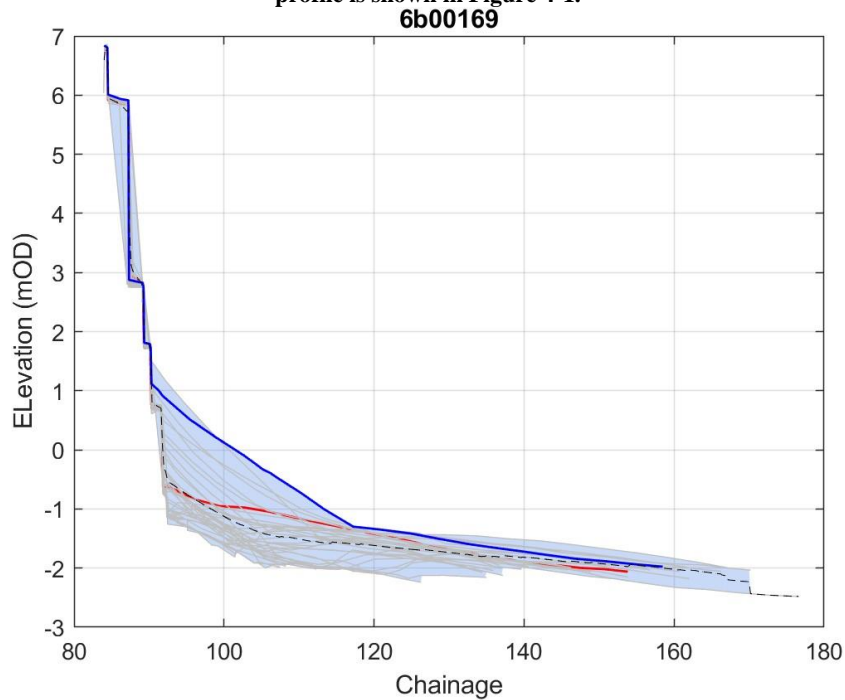

Figure B-4. Profile envelope (blue shading) for all data for the period 2007 – 2023 at SWCMP profile 6b00169. Individual profile observations are plotted in grey and the mean elevation is indicated by a dashed line. Blue line signifies the most recent profile from 2023 and a red line indicates the initial profile from 2007. The location of this profile is shown in Figure 4-1.

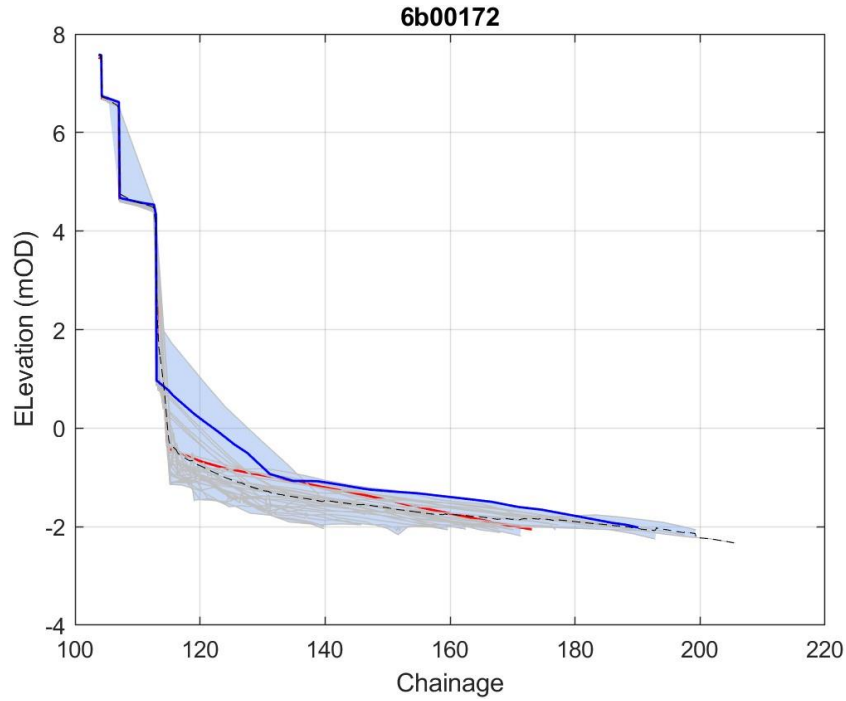

Figure B-5. Profile envelope (blue shading) for all data for the period 2007 – 2023 at SWCMP profile 6b00172. Individual profile observations are plotted in grey and the mean elevation is indicated by a dashed line. Blue line signifies the most recent profile from 2023 and a red line indicates the initial profile from 2007. The location of this profile is shown in Figure 4-1.

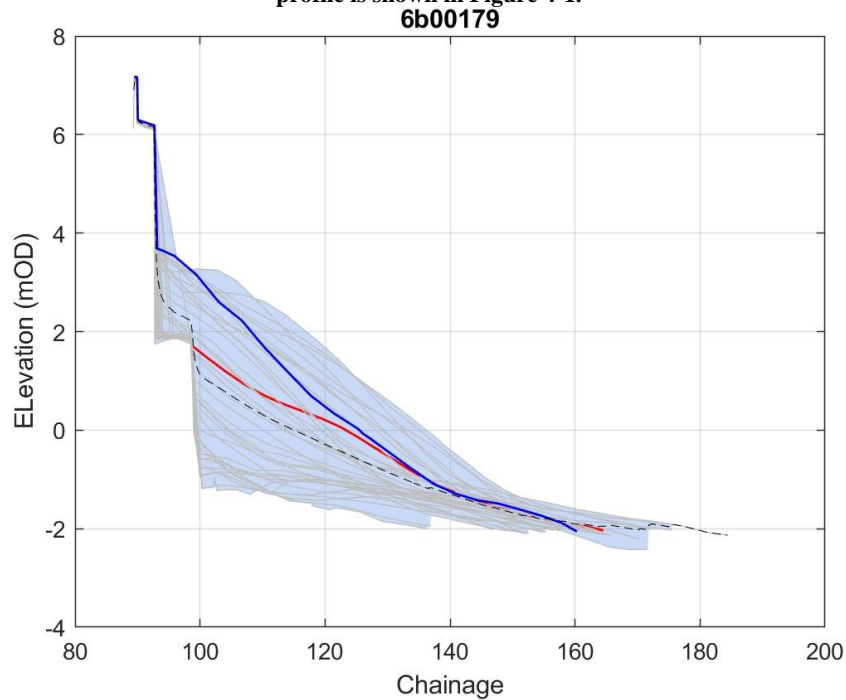

Figure B-6. Profile envelope (blue shading) for all data for the period 2007 – 2023 at SWCMP profile 6b00179. Individual profile observations are plotted in grey and the mean elevation is indicated by a dashed line. Blue line signifies the most recent profile from 2023 and a red line indicates the initial profile from 2007. The location of this profile is shown in Figure 4-1.

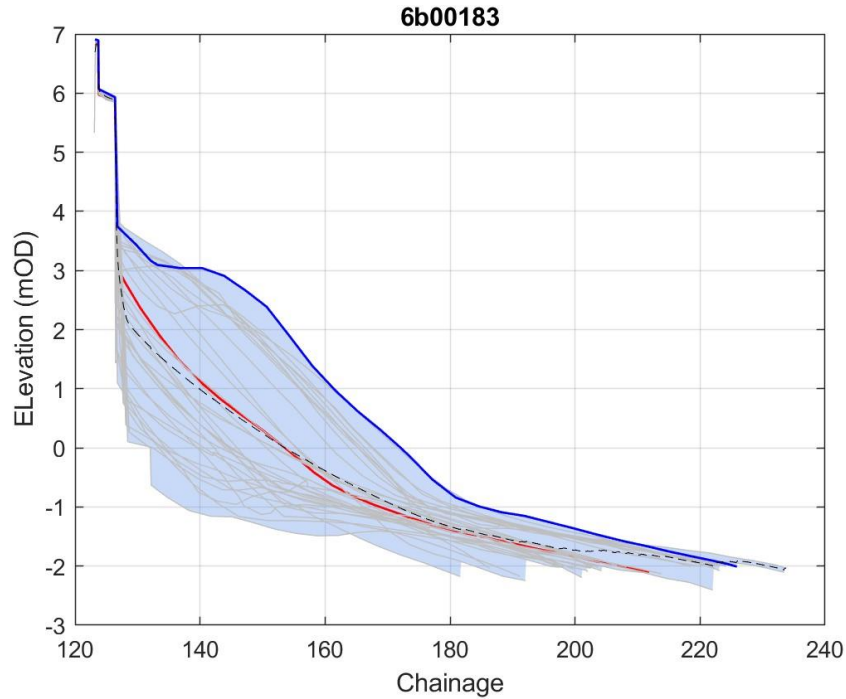

Figure B-7. Profile envelope (blue shading) for all data for the period 2007 – 2023 at SWCMP profile 6b00183. Individual profile observations are plotted in grey and the mean elevation is indicated by a dashed line. Blue line signifies the most recent profile from 2023 and a red line indicates the initial profile from 2007. The location of this profile is shown in Figure 4-1.

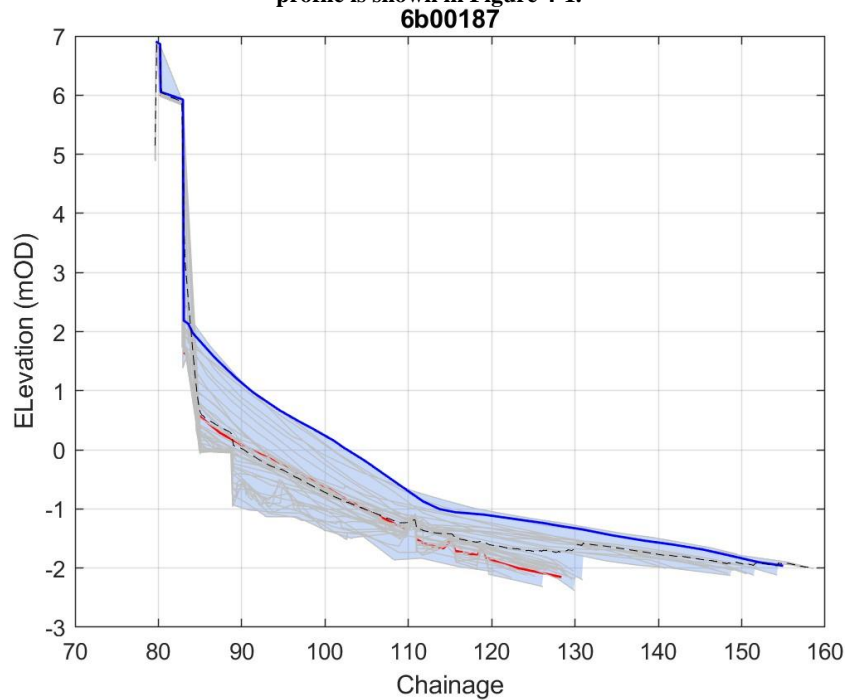

Figure B-8. Profile envelope (blue shading) for all data for the period 2007 – 2023 at SWCMP profile 6b00187. Individual profile observations are plotted in grey and the mean elevation is indicated by a dashed line. Blue line signifies the most recent profile from 2023 and a red line indicates the initial profile from 2007. The location of this profile is shown in Figure 4-1.

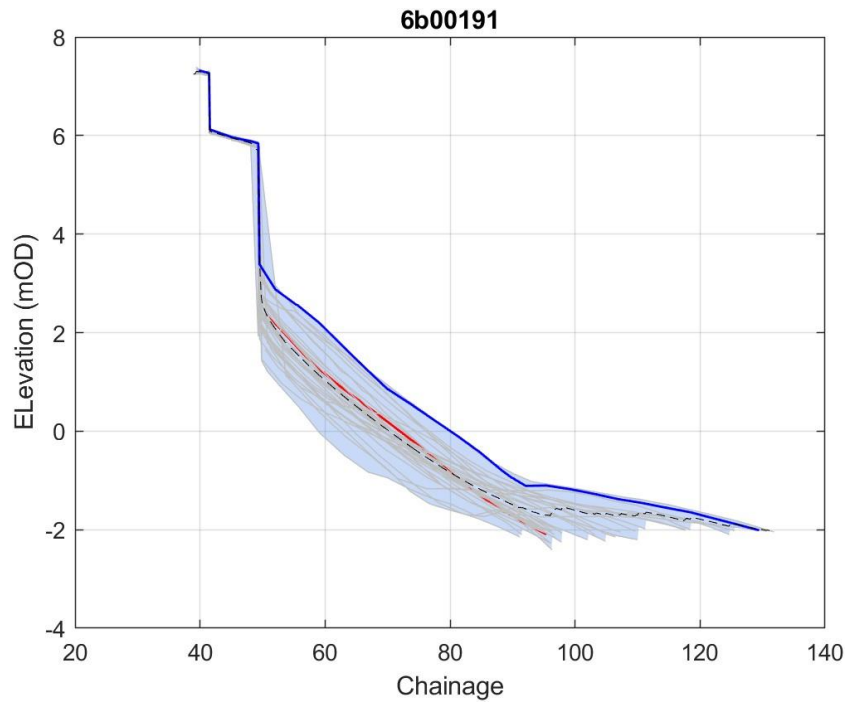

Figure B-9. Profile envelope (blue shading) for all data for the period 2007 – 2023 at SWCMP profile 6b00191. Individual profile observations are plotted in grey and the mean elevation is indicated by a dashed line. Blue line signifies the most recent profile from 2023 and a red line indicates the initial profile from 2007. The location of this profile is shown in Figure 4-1.

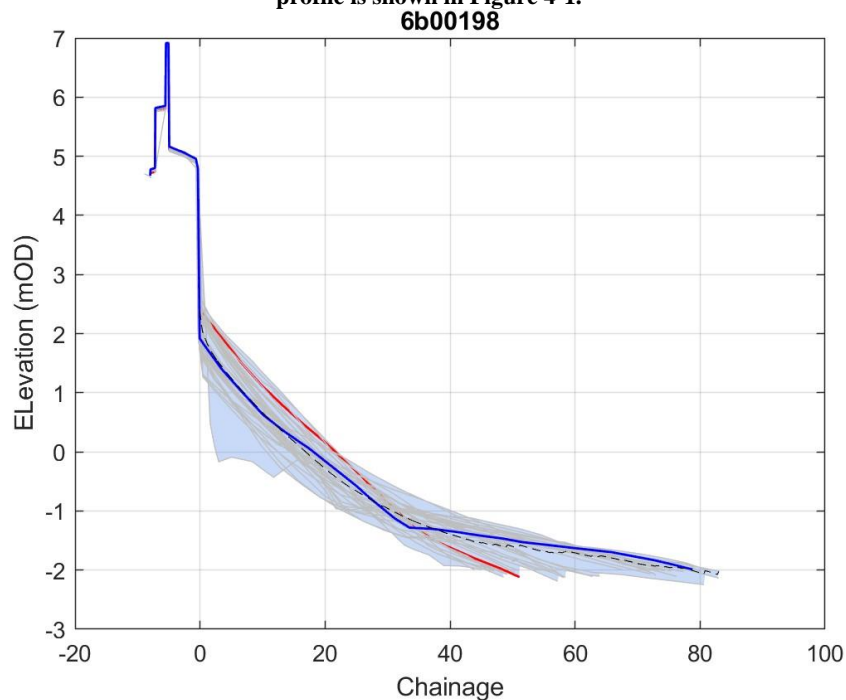

Figure B-10. Profile envelope (blue shading) for all data for the period 2007 – 2023 at SWCMP profile 6b00198. Individual profile observations are plotted in grey and the mean elevation is indicated by a dashed line. Blue line signifies the most recent profile from 2023 and a red line indicates the initial profile from 2007. The location of this profile is shown in Figure 4-1.

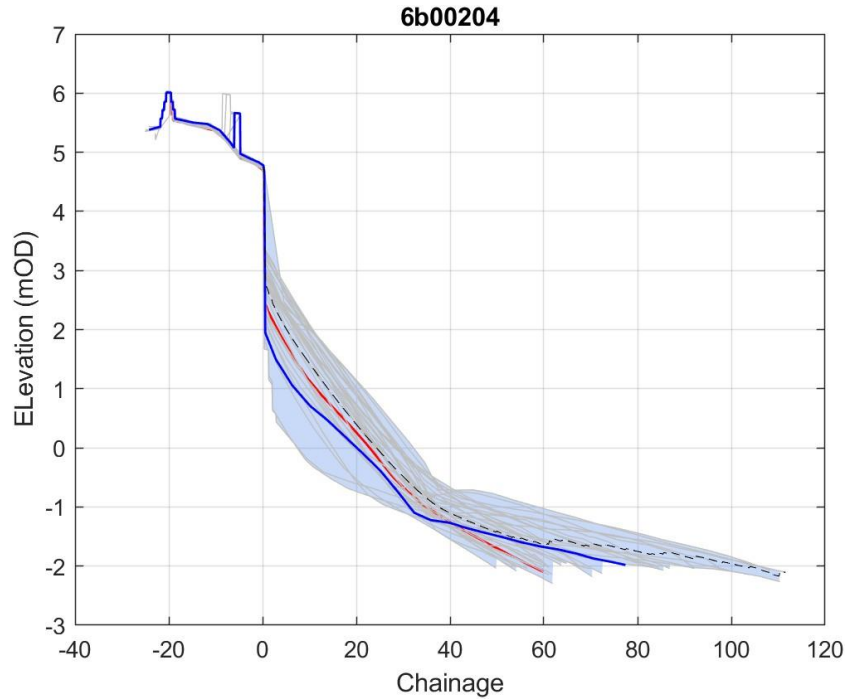

Figure B-11. Profile envelope (blue shading) for all data for the period 2007 – 2023 at SWCMP profile 6b00204. Individual profile observations are plotted in grey and the mean elevation is indicated by a dashed line. Blue line signifies the most recent profile from 2023 and a red line indicates the initial profile from 2007. The location of this profile is shown in Figure 4-1.

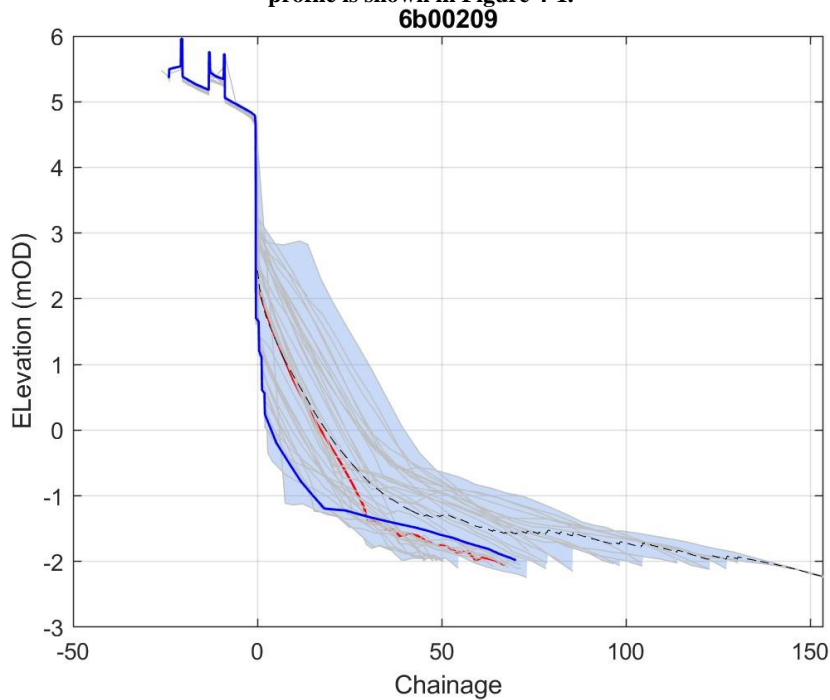

Figure B-12. Profile envelope (blue shading) for all data for the period 2007 – 2023 at SWCMP profile 6b00209. Individual profile observations are plotted in grey and the mean elevation is indicated by a dashed line. Blue line signifies the most recent profile from 2023 and a red line indicates the initial profile from 2007. The location of this profile is shown in Figure 4-1.

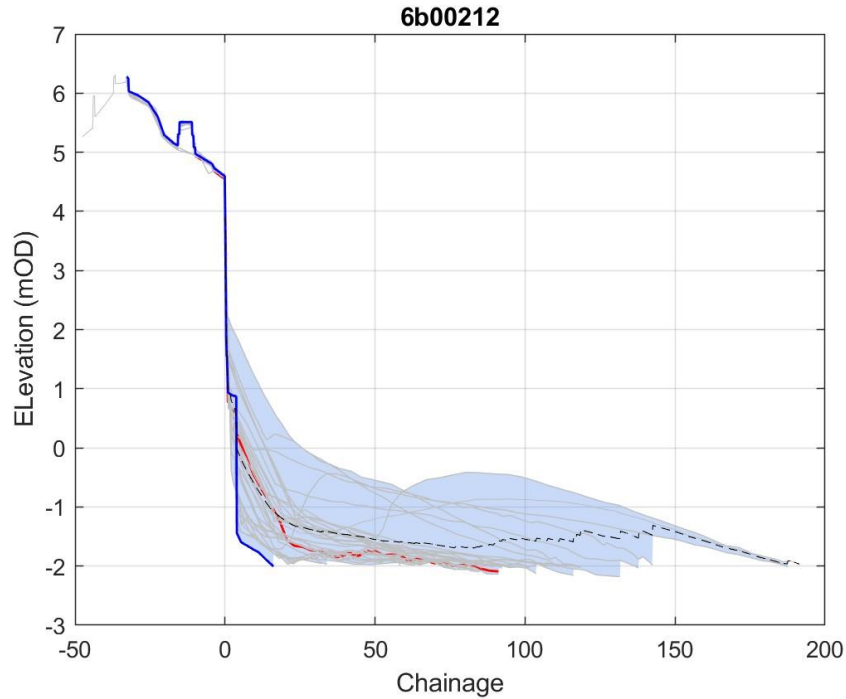

Figure B-13. Profile envelope (blue shading) for all data for the period 2007 – 2023 at SWCMP profile 6b00212. Individual profile observations are plotted in grey and the mean elevation is indicated by a dashed line. Blue line signifies the most recent profile from 2023 and a red line indicates the initial profile from 2007. The location of this profile is shown in Figure 4-1.

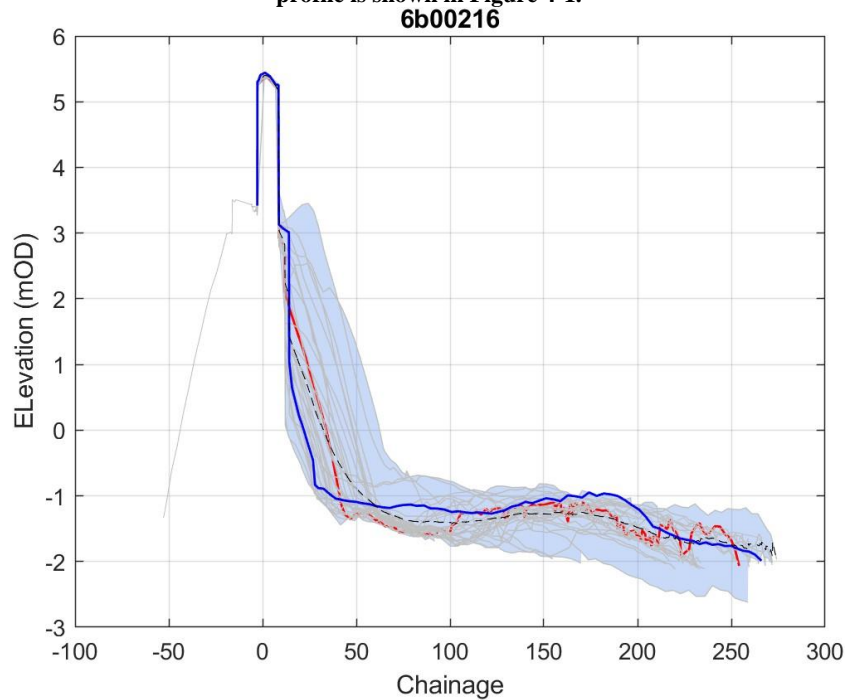

Figure B-14. Profile envelope (blue shading) for all data for the period 2007 – 2023 at SWCMP profile 6b00216. Individual profile observations are plotted in grey and the mean elevation is indicated by a dashed line. Blue line signifies the most recent profile from 2023 and a red line indicates the initial profile from 2007. The location of this profile is shown in Figure 4-1.

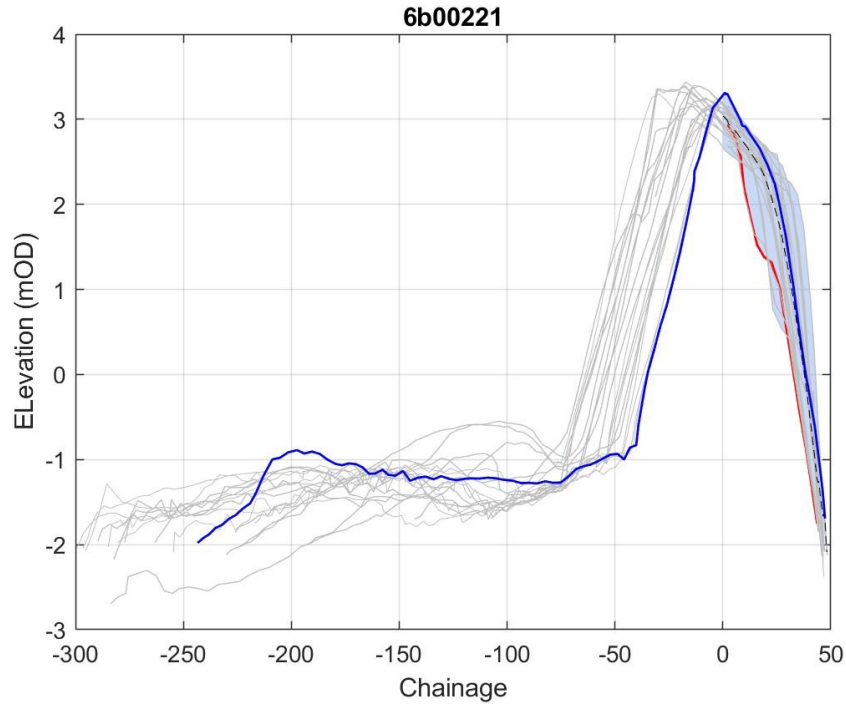

Figure B-15. Profile envelope (blue shading) for all data for the period 2007 – 2023 at SWCMP profile 6b00221. Individual profile observations are plotted in grey and the mean elevation is indicated by a dashed line. Blue line signifies the most recent profile from 2023 and a red line indicates the initial profile from 2007. The location of this profile is shown in Figure 4-2.

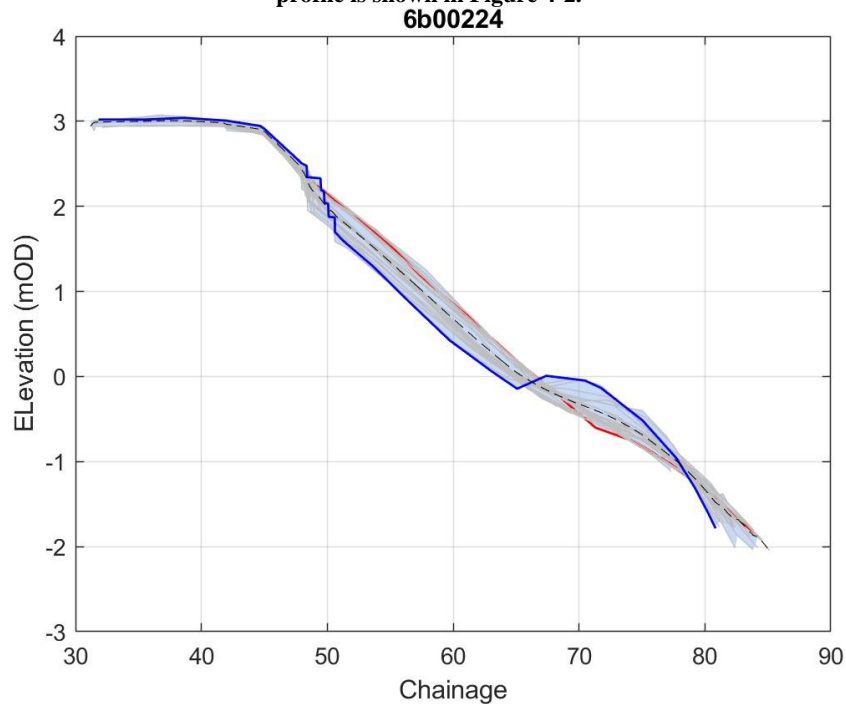

Figure B-16. Profile envelope (blue shading) for all data for the period 2007 – 2023 at SWCMP profile 6b00224. Individual profile observations are plotted in grey and the mean elevation is indicated by a dashed line. Blue line signifies the most recent profile from 2023 and a red line indicates the initial profile from 2007. The location of this profile is shown in Figure 4-2.

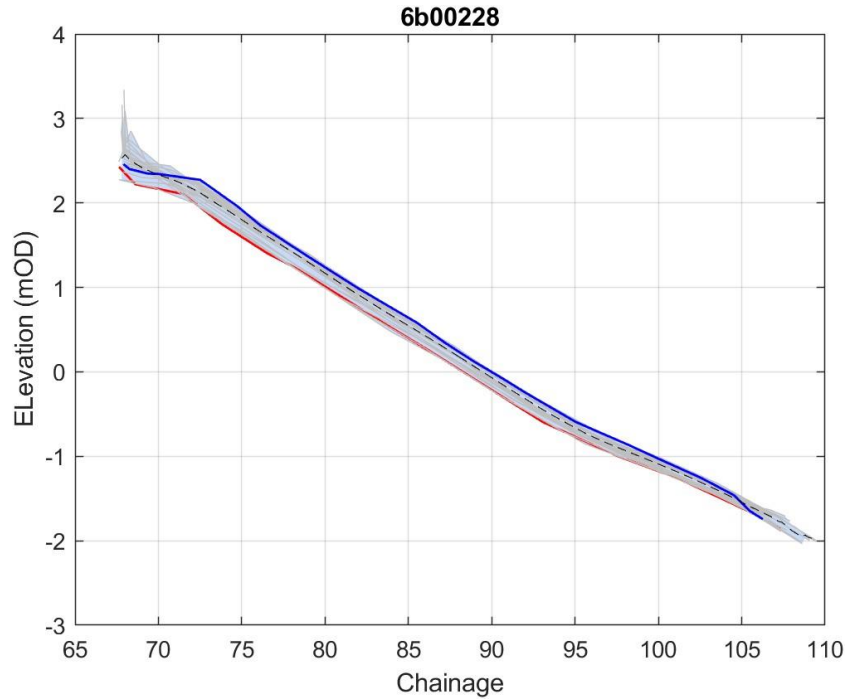

Figure B-17. Profile envelope (blue shading) for all data for the period 2007 – 2023 at SWCMP profile 6b00228. Individual profile observations are plotted in grey and the mean elevation is indicated by a dashed line. Blue line signifies the most recent profile from 2023 and a red line indicates the initial profile from 2007. The location of this profile is shown in Figure 4-2.

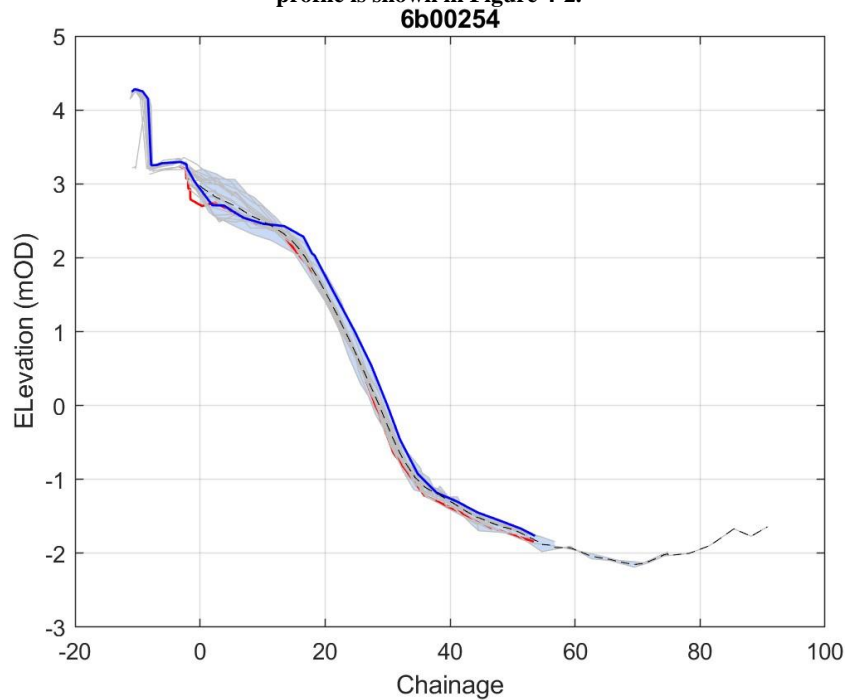

Figure B-18. Profile envelope (blue shading) for all data for the period 2007 – 2023 at SWCMP profile 6b00254. Individual profile observations are plotted in grey and the mean elevation is indicated by a dashed line. Blue line signifies the most recent profile from 2023 and a red line indicates the initial profile from 2007. The location of this profile is shown in Figure 4-2.

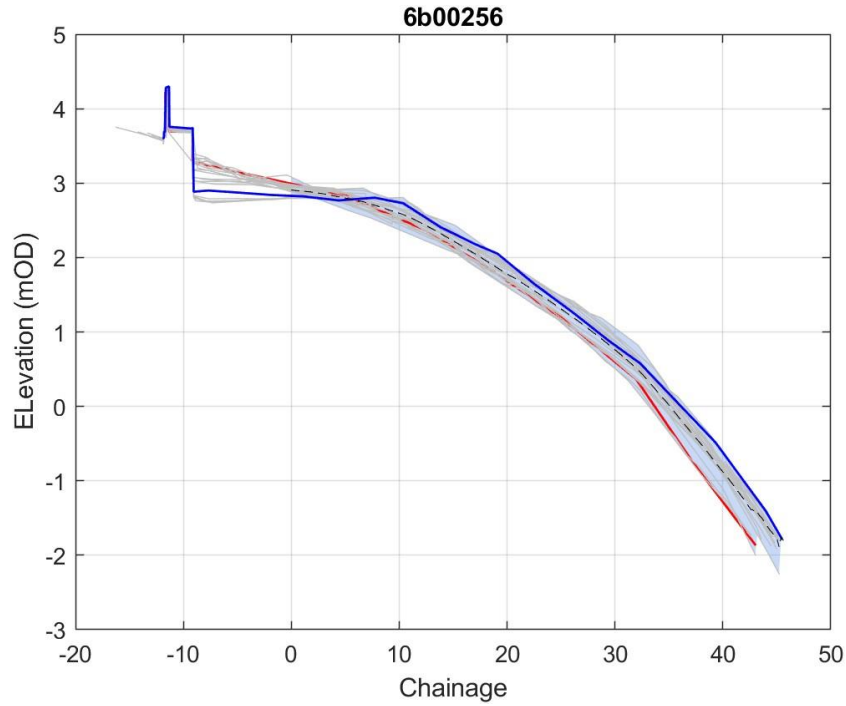

Figure B-19. Profile envelope (blue shading) for all data for the period 2007 – 2023 at SWCMP profile 6b00256. Individual profile observations are plotted in grey and the mean elevation is indicated by a dashed line. Blue line signifies the most recent profile from 2023 and a red line indicates the initial profile from 2007. The location of this profile is shown in Figure 4-2.

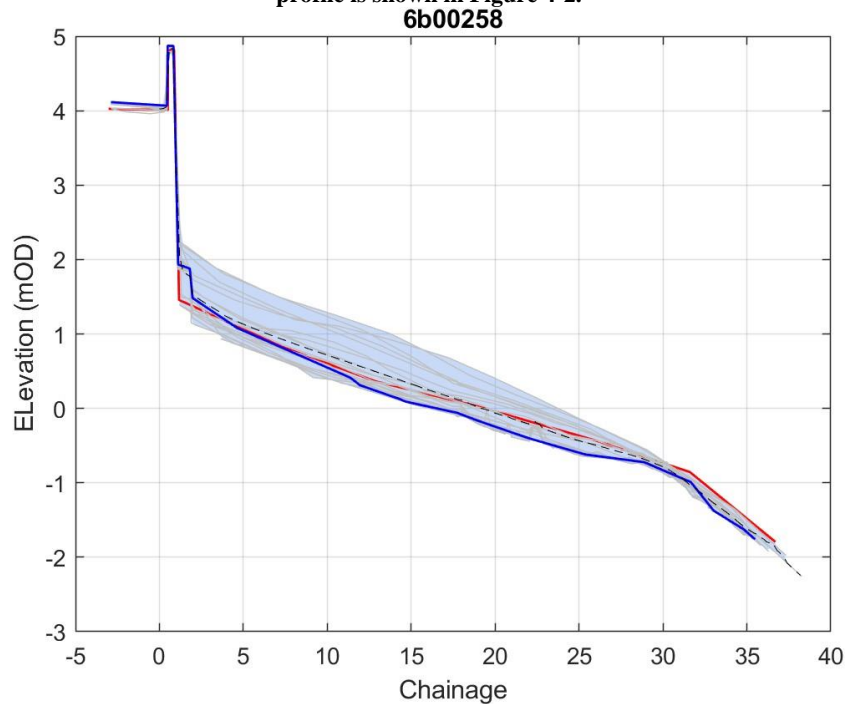

Figure B-20. Profile envelope (blue shading) for all data for the period 2007 – 2023 at SWCMP profile 6b00258. Individual profile observations are plotted in grey and the mean elevation is indicated by a dashed line. Blue line signifies the most recent profile from 2023 and a red line indicates the initial profile from 2007. The location of this profile is shown in Figure 4-2.

Appendix C Hydro-morphodynamic modelling using Delft3D-FM

The hydro-morphodynamic model used in this study was developed in Delft3D-FM which is a multi-dimensional hydrodynamic and transport simulation program for non-steady flows and horizontal transport of matter (Deltares, 2014). The Delft3D-FM model comprised of the modules D-WAVE for wave propagation modelling coupled with D-FLOW Flexible Mesh for hydrodynamic flows and D-MORPHOLOGY for sediment transport and morphological changes. The modules exchange information every 15 minutes of simulated time so that the waves, flows, and morphology all iteratively influence one another. This helps maintain a smooth and physically realistic morphological evolution (Luijendijk, de Schipper, & Ranasinghe, 2019). This integrated model was used to compute hydrodynamics, waves and sediment transport under the influence of tidal and wave-driven currents.

C.1 Model domain

The model domain was developed using bathymetric and topographic data from several sources which were merged to obtain a complete digital elevation model of the seabed and dry land areas (Figure C-1). The model domains were developed using the following data:

- Multibeam bathymetry data collected in 2020 for the SWCMP with a horizontal resolution of 0.5 m.
- Multibeam bathymetry data collected in 2018 for Network Rails' South West Rail Resilience Programme (SWRRP) with a horizontal resolution of 0.01 m.
- EMODnet single beam bathymetry data with ~115 m horizontal resolution (<https://emodnet.ec.europa.eu/en/bathymetry>).
- Topography data was obtained from SWCM LiDAR surveys from the year 2020 with a spatial resolution of 1m.

In addition, some engineered structures were implemented in the model, as detailed in Section C.8.

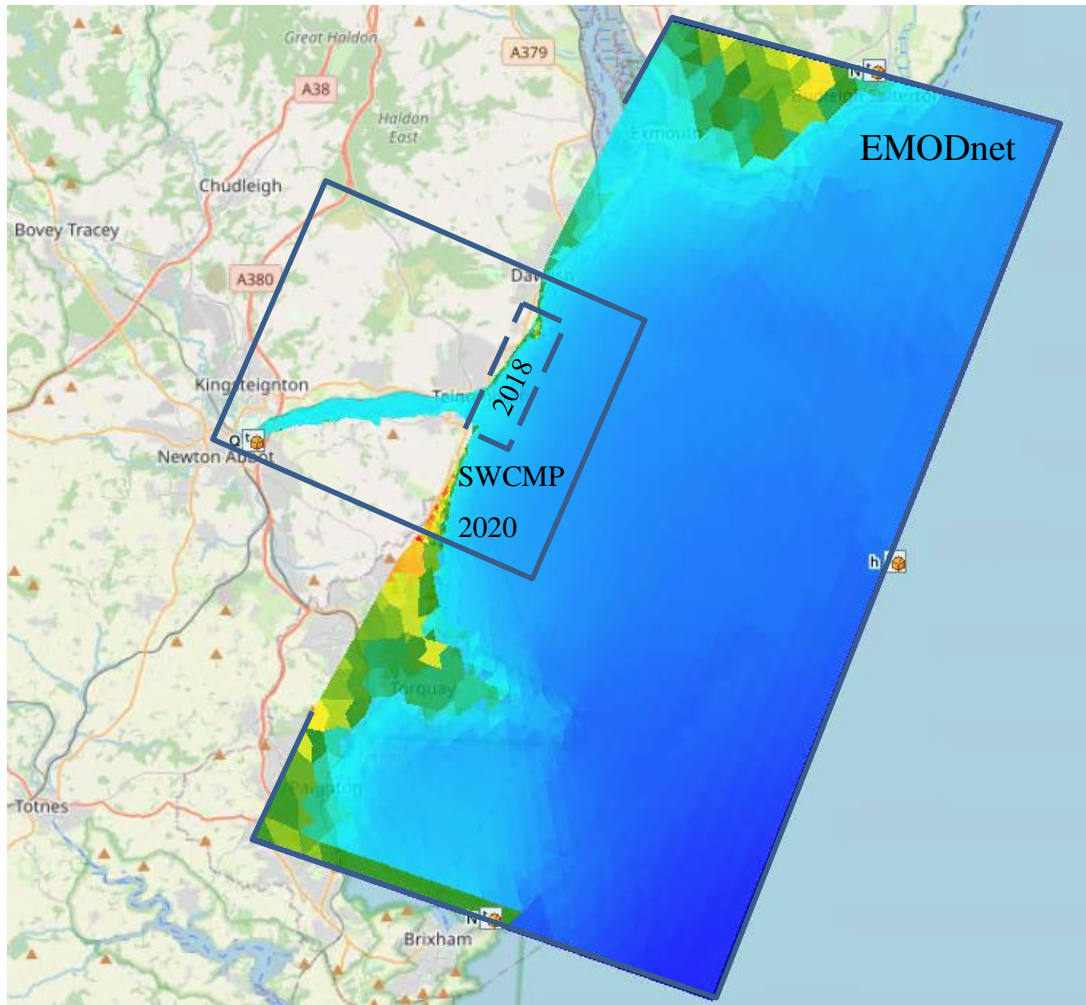

Figure C-1. Interpolated bathymetry of the model domain, consisting of EMODnet single beam bathymetry, SWCMP multibeam bathymetry (‘SWCMP 2020’), and a subset area of multibeam bathymetry (‘2018’) interchanged with the SWCMP 2020 data to simulate morphological change between 2018 and 2020. The SWCMP 2020 data also utilised LiDAR data collected in that year to provide topographic elevations at the shore and in the estuary.

C.2 Model Grid

The model domain consists of three grids as illustrated in Figure C-2. In the D-FLOW module, a flexible mesh was generated with resolutions ranging from 30 m in shallow areas to 700 m at the offshore boundary. The grid covers an area of 30 km along the coast and 12 km in the cross-shore direction. It was essential for the flow model to cover a sufficiently large area to ensure that there was no influence of the estuary on the model boundary, and to correctly generate and propagate tidal flows.

The wave module D-WAVE uses two rectangular grids, consisting of a coarse outer grid and a fine inner grid. The nested inner grid has a spatial resolution of 20 x 75 m and is centred around the area of interest to resolve detailed wave shoaling and refraction processes near the shore, while the coarse outer grid has a resolution of 45 x 170 m and is used to propagate waves from nearshore wave forcing nodes (Figure C-2) at approximately -14 mODN depth in to the inner grid.



Figure C-2. Model grid showing combined D-FLOW flexible mesh (orange) and two meshes from the D-WAVE module (grey). Upper left panel: overview of all the model grids, forcing boundaries (blue lines), and wave (red triangles) and tide (red circles) forcing nodes. Upper right panel: two grids used in the wave model. Lower panel:

detailed view of the D-FLOW flexible mesh grid in Teignmouth delta and beach with resolution of 30 m in the shallowest areas.

C.3 Forcing conditions

The model boundaries were forced with wave, tide, and riverine discharge in order to drive flows within the model. Wave forcing conditions were provided by Dawlish wave buoy as well as the CMEMS AMM15 wave model (1.5 km spatial resolution) and tides were extracted from the CMEMS AMM7 hydrodynamic model (7 km spatial resolution). Riverine discharge was obtained from the UK National River Flow Archive (<https://nrfa.ceh.ac.uk>).

Forcing conditions were determined depending on the scenario simulated:

- Multi-annual scenario – time-series of wave height, period, direction and tides from 14.05.2018 to 12.02.2020, as well as average river discharge rate
- Two storm-threshold wave scenarios – 3.5 days of temporally uniform storm waves from the south and east directions (Table C-1), combined with a mean spring tide time-series, and average river discharge rate
- Two tide only scenarios – 3.5 days of mean spring tide time-series and mean neap tide time-series, and average river discharge rate

Tides were imposed at the offshore boundary of the D-FLOW model, waves were applied at the offshore boundary of the outer wave model grid, and discharge was applied at the western extent of the Teign estuary (Figure C-2).

C.3.1 Waves

The outer wave grid was forced with either temporally varying wave heights, periods and directions for the multi-annual scenario (14.05.2018 to 12.02.2020) or with temporally static storm wave conditions applied over a 3.5-day time period, as described in Table C-1.

While the Dawlish wave buoy provides the most accurate wave data in the region, it represents only a single point in space. The AMM15 wave model operates at a spatial resolution of 1.5 km, providing spatially varying forcing data at various locations along the outer model boundary, which helps to describe gradients in wave height that happen along the coast due to Hope's Nose headland. However, at Teignmouth the AMM15 model does not capture the highest storm peaks accurately, as illustrated in Figure C-3 which demonstrates it underestimated storm wave heights by 0.5–2 m during the stormy winter of 2013-14.

To address this limitation, the wave buoy data was used as the primary source of wave model forcing. To capture along-coast gradients in wave height, adjustments were made to the wave buoy data along the forcing boundary, based on analysis of the AMM15 wave heights along the boundary. As the wave buoy is in close proximity to AMM15 forcing node 3 (Figure C-2), the average ratio in wave height between the CMEMS data obtained at node 3 and the other AMM15 nodes was calculated. The measured wave height from the buoy was then applied at all four nodes along the offshore boundary by multiplying the height by the computed adjustment factor for each location. This showed that wave height differs little between the wave buoy (node 3) and nodes 2 and 4, but that node 1 had significantly lower wave heights under southerly waves due to sheltering from Hope’s Nose headland, with an average ratio of 0.6 times the height at node 3. While this is a simplification of the real gradient in wave conditions along the boundary, it ensures that storm wave heights are not underrepresented while also capturing the increase in wave height from south to north that occurs under southerly approaching waves. Under easterly approaching waves, the wave height ratio of 0.6 at node 1 is not realistic but does not affect simulated conditions at the shore as easterly waves propagate from node 1 out of the lateral model boundary.

The total wave power and alongshore orientated southerly and easterly components of the wave power are shown in Figure 2-7. Dashed lines illustrate the 21-month period used in the multi-annual simulation. Analysis reveals that approximately 70% of the alongshore power came from the south, and only 30% from the east during the 21-month simulation period, which is consistent with the entire 13-year dataset (67% - 33%). Additionally, the annual total wave power over the 21-month simulation is 1.7901×10^8 , which is also comparable to the recorded annual mean power of 1.6046×10^8 over entire wave buoy record. This indicates that the two-year period simulated is highly representative of the longer-term wave record, and should provide computed sediment fluxes with the correct net direction and order of magnitude.

Table C-1. Summary of storm-threshold wave conditions from the south and east, each with a probability of occurrence of four times per year (1-in-0.25 years). Nodes 1 to 4 represent model forcing nodes spaced evenly along the seaward boundary of the large-scale wave grid, arranged from south to north.

Scenario	Node 1			Node 2			Node 3			Node 4		
	<i>Hs</i> (m)	<i>Tp</i> (s)	<i>Dm</i> (°)	<i>Hs</i> (m)	<i>Tp</i> (s)	<i>Dm</i> (°)	<i>Hs</i> (m)	<i>Tp</i> (s)	<i>Dm</i> (°)	<i>Hs</i> (m)	<i>Tp</i> (s)	<i>Dm</i> (°)
1-in-0.25 yr RP wave S	1.6	7.8	156	2.7	8.1	166	2.7	8.4	170	2.8	9.3	178
1-in-0.25 yr RP wave E	2.0	7.7	105	2.2	7.5	114	2.1	7.5	116	1.9	7.5	117

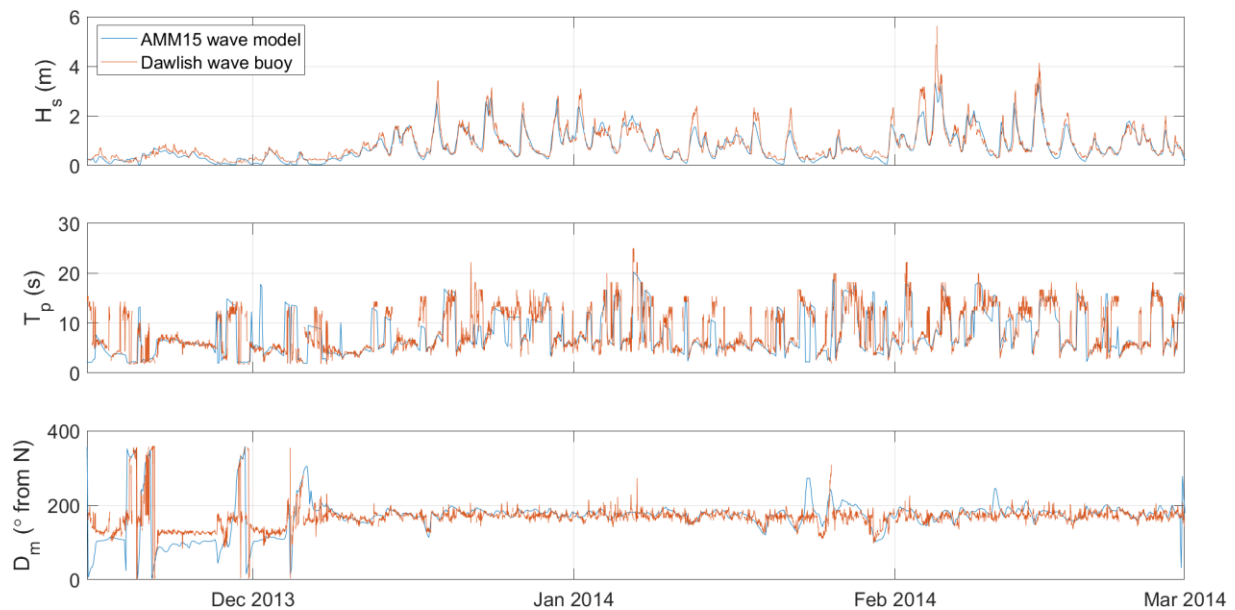

Figure C-3. Comparison of Dawlish waverider buoy data to AMM15 wave model hindcast predictions made at approximately the same location. The time period shown covers the extreme winter period of 2013-14.

C.3.2 Tides

Water level time series were obtained from the CMEMS AMM7 hydrodynamic model with a resolution of 7 km. For the multi-annual scenario, tide data spanned from May 2018 to February 2020 (Figure C-6). Additionally, the two storm scenarios with 3.5 days duration each used mean spring tides, illustrated in Figure C-4. Two separate scenarios were simulated with tides only, using mean spring tide and mean neap tide cycles (Figure C-4). The tide time-series were applied at the four nodes at the offshore boundary in the D-FLOW model (Figure C-2) to force variation in water level along the boundary and generate tidal flows within the model.

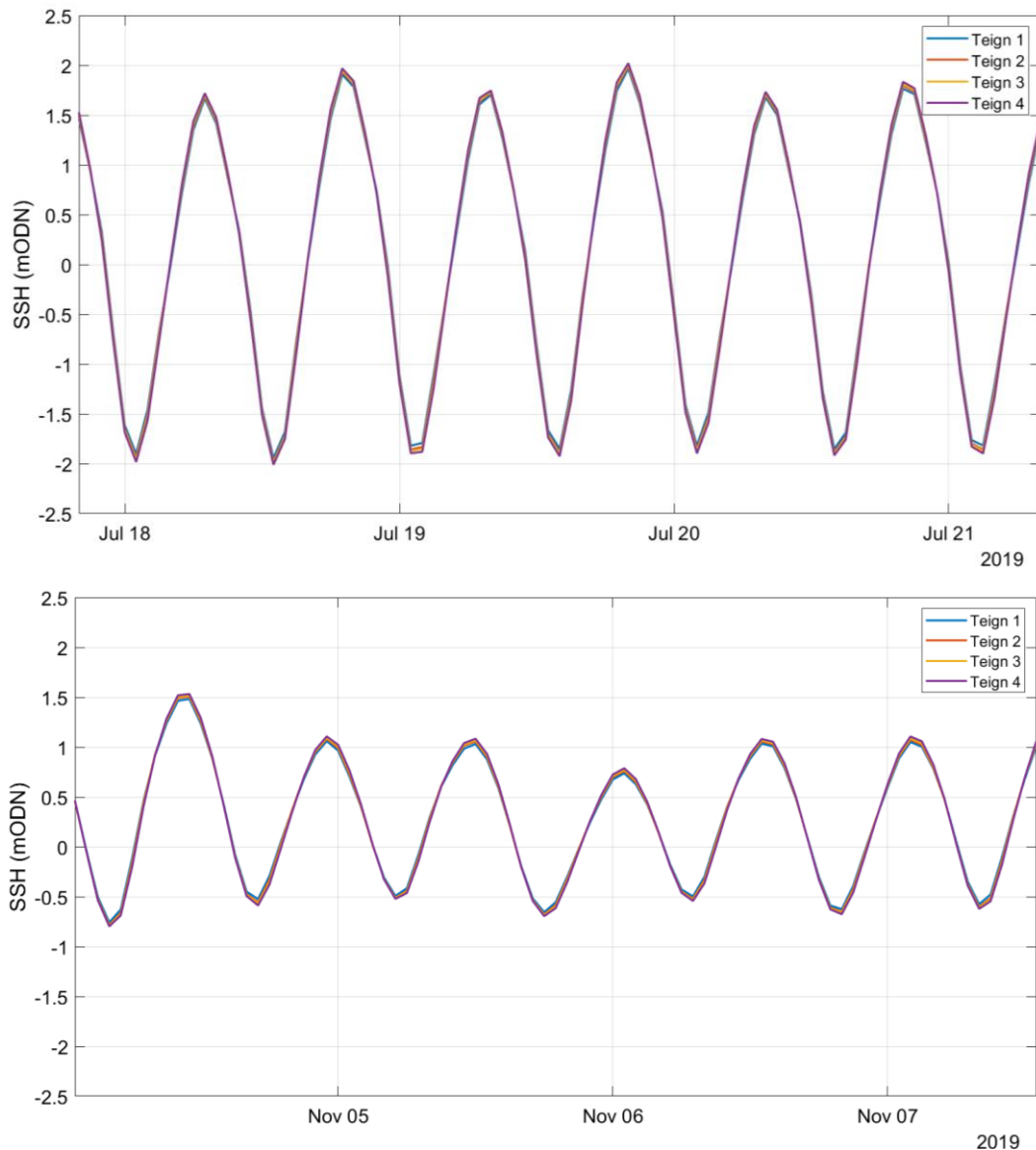

Figure C-4. Mean spring (upper) and neap (lower) tide time-series applied at the four nodes at the offshore boundary in the D-FLOW model (Figure C-2).

C.3.3 Riverine discharge

Riverine discharge rates were derived from monitoring data from nearby Preston station. Mean daily rates spanning from 1956 to 2007 period were averaged to establish an average discharge rate of 9 m³/s for use in the model scenarios. However, the model simulations indicate that the influence of the river discharge is insignificant as the flow generated by it has a negligible effect on estuary flow velocity. This aligns with previous findings from ABPmer (2012b) that concluded that freshwater discharges up to the Q90 value for the river Teign had a negligible influence on estuary hydrodynamics. (Section 2.2).

C.4 Sediment characteristics

In the model, various sediment sizes were tested to account for the wide range of observed sediments in Teignmouth. When a single uniform sediment was used throughout, there was either over-erosion and overly dynamic behaviour in the lower estuary or minimal transport and underprediction of dynamics along the seaward frontage. Consequently, it was necessary to define two distinct sediment regions in order to capture the stark difference in grain size between the estuary/ebb-tidal delta and the Seafront Beach, as illustrated in Figure C-5. The spatial areas of the two different sediment classes were estimated based on quantitative sediment samples from the 1999 Coast3d project and the 2018 SWRRP project, as well as qualitative sediment classification conducted in 2023 for the SWCMP. The two primary sediment classes are:

- **Fine gravel within the lower estuary and ebb-shoal delta**, characterised by $D_{50} = 3$ mm (average grain size measured in the estuary channels)
- **Coarse-very coarse sand outside the estuary on the seaward frontage**, characterised by $D_{50} = 1$ mm (average grain size measured on the intertidal beach)

A sensitivity analysis was conducted to explore how the sediment grain sizes affect the model predictions (Section C.7.2). Subsequently, three sediment size scenarios were tested in the model:

- $D_{50} = 3$ mm in the estuary and ebb-tidal delta and $D_{50} = 1$ mm on the exposed frontage (referred to as the primary scenario, or 3 mm/1 mm run)
- $D_{50} = 3$ mm in the estuary and ebb-tidal delta and $D_{50} = 0.3$ mm on the exposed frontage (referred to as the 3 mm/0.3 mm run)
- $D_{50} = 1$ mm used throughout the entire model domain (referred to as the uniform 1 mm run)

In deeper water, fine sand of ~ 0.15 mm has been observed. However, as this is beyond the theoretical Depth of Closure, it is disregarded in the modelling. Areas of bed rock were also implemented in the model in the vicinity of Holcombe Headland, Ness Point, and in the estuary mouth, where exposed bed rock is known to be present (Figure C-5). This is important in limiting the local sediment supply and avoiding overprediction of bed erosion in these areas.

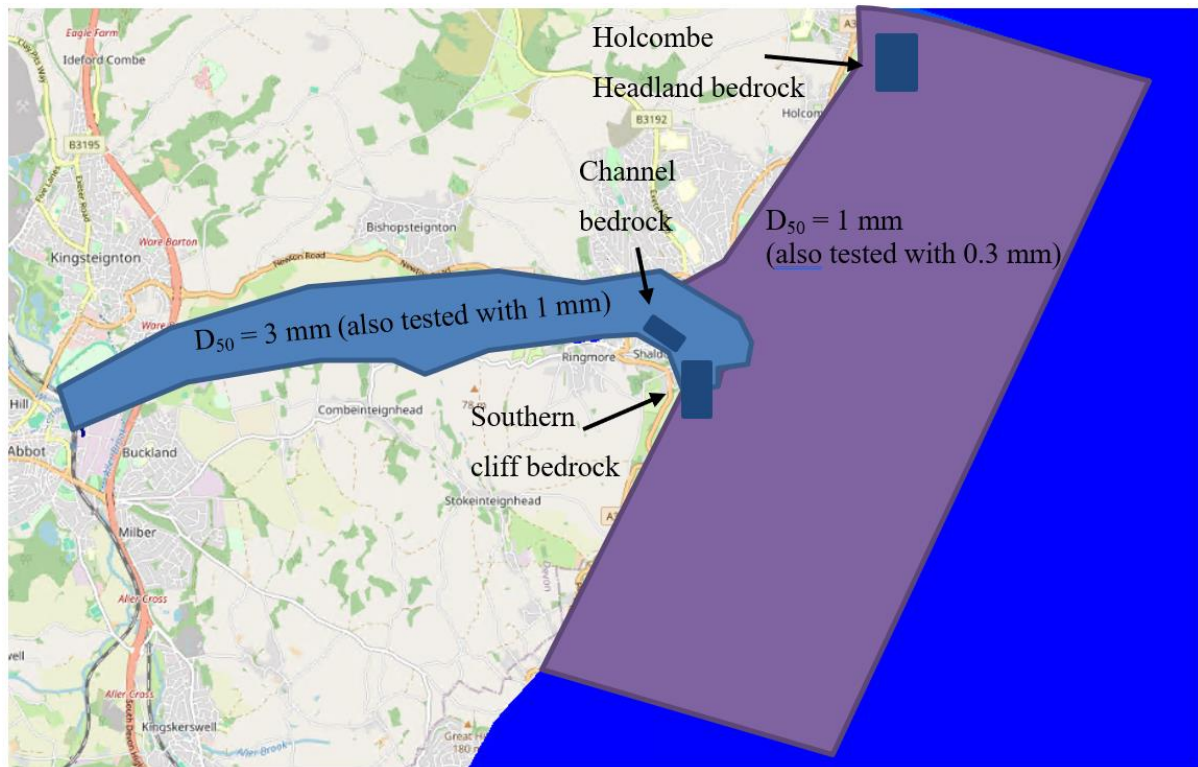

Figure C-5. Overview of the different sediment sizes and areas of exposed bedrock used in the model. Blue colour designates the area excluded from the morphology calculations.

C.5 Morphodynamic acceleration techniques

One of the major challenges for long-term model simulations is their duration and associated computational expense. A common modelling approach to circumvent this issue is to use acceleration techniques. Two methods were applied in this study: (1) a morphological acceleration factor (morfac) developed by Lesser, Roelvink, van Kester, and Stelling (2004), and (2) a forcing reduction technique developed by Luijendijk et al. (2019). The combination of these techniques is sometimes referred to as the ‘compressed, filtered brute force technique’ (Luijendijk et al., 2017). These methods have been successfully applied in previous studies to simulate morphological change (Knaapen & Joustra, 2012; Luijendijk et al., 2019; Luijendijk et al., 2017; Morgan et al., 2020; Roshanka Ranasinghe et al., 2011; Roelvink, 2006).

For running the multi-annual scenario, the period from 14.05.2018 to 12.02.2020 was selected due to the availability of the bathymetry data at the start and end of the period, which is essential for validating predicted morphological changes. The complete timeseries of wave height is depicted in Figure C-6 (upper panel). The forcing reduction method was applied whereby waves smaller than $H_s = 0.5$ m were disregarded from the simulation (Figure C-6; middle panel), as they were shown to contribute negligibly to the sediment transport through the sensitivity testing detailed in section C.7. To further accelerate the simulation, a morphological acceleration factor (morfac) of 5 was applied to the filtered data as shown

in Figure C-6 (lower panel), which multiplies the amount of predicted erosion/deposition at each timestep by the value of morfac. This enables the wave forcing time series to be divided by the morfac value (i.e. compressing it by a factor of 5), to save computation time. Consequently, the simulated time was reduced from 639 days to 50 days which represents a 92% reduction in computational time. The tide timeseries must remain uncompressed, as if the tide timestep was reduced, tidal velocities would be increased unrealistically. The compressed wave time series is therefore applied over a truncated and non-compressed tidal time forcing series, under the assumption that the time scale of the tides can be decoupled from the time scale of the waves and morphology (Luijendijk et al., 2019).

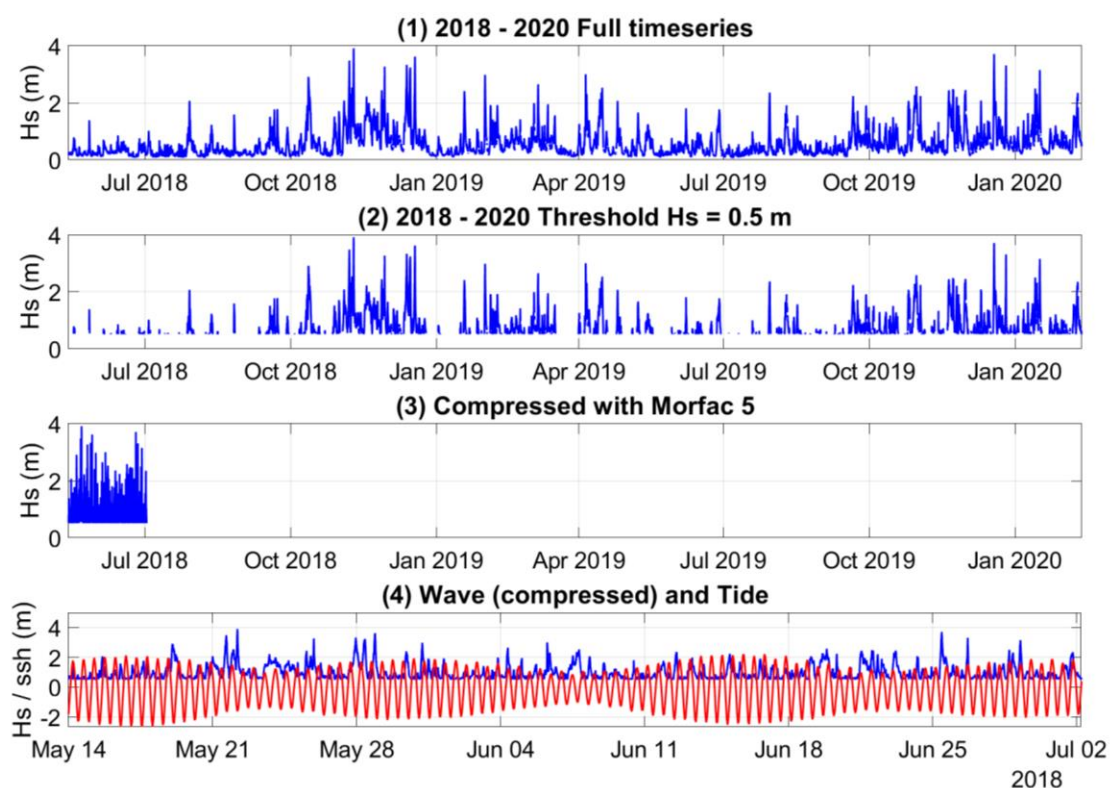

Figure C-6. Overview of morphodynamic acceleration methods. Step (1) Full timeseries of wave height (14.05.2018 to 12.02.2020) derived from Dawlish wave buoy for a multi-annual simulation. Step (2) Filtered wave height with a threshold $H_s = 0.5$ m. Step (3) Compression of the filtered wave heights with $\text{morfac} = 5$. Step (4) Filtered and compressed wave conditions and non-compressed water levels.

C.6 Calibration and validation

The Delft3D-FM flow model was initially calibrated using existing model settings from previous modelling studies of Teignmouth. The key free parameters controlling flow velocities in the model relate to the bed friction settings. Previous modelling studies that undertook calibration against in-situ Acoustic Doppler Current Profiler (ADCP) measurements at Teignmouth found that optimised settings

were achieved with a Chezy friction coefficient of $65 \text{ m}^{1/2}/\text{s}$ (Bernardes, 2005; Sutherland, Walstra, Chesher, Van Rijn, & Southgate, 2004). We therefore adopt this setting in the present modelling study.

Flow measurements were not collected as part of the present study, and as such velocity observations coinciding with the 2018 and 2020 bathymetric data sets were not available, making it impractical to directly validate the flow velocities in the model. However, velocity measurements made in the mouth of the estuary in 1999 during the Coast3D project (Sutherland, Waters, & Whitehouse, 2001; Whitehouse & Sutherland, 2001) were used to provide a sense-check on the predicted flow rates adjacent to the estuary. As this area is void of seabed sediments, it can be safely assumed that negligible morphological change has occurred at the location of the flow measurements, meaning that the 1999 flow measurements can be utilised to provide a sense-check on the velocities predicted by the model developed using the 2018 bathymetric data.

Figure C-7 presents a comparison between the measured and modelled depth-averaged flow velocities over a 12-day period, where the model was forced by wave and tide conditions from AMM15 and AMM7 wave and tide hindcast data. The Root Mean Square Error (RMSE) was found to be 0.34 m/s , the Pearson correlation coefficient (R) was 0.41 , and the Bias was 0.05 . While the relatively poor RMSE and correlation do not indicate a close quantitative agreement, the model provides good qualitative agreement in both the phase and magnitude of the depth-averaged flows and reproduces the change in velocity under neap and spring tides. Furthermore, the low level of Bias indicates the the model is equally likely to overestimate or underestimate measured values. Given the bathymetry in the model is almost 20 years out of sync with the measurements (which will affect both wave dissipation patterns and flow magnitudes/directions along the frontage), it can be assumed that a higher level of model skill would be achieved if concurrent flow measurements were available. The qualitative agreement demonstrates that the model adequately reproduces the estuary flow magnitudes and is useful for the purposes of predicting sediment transport fluxes.

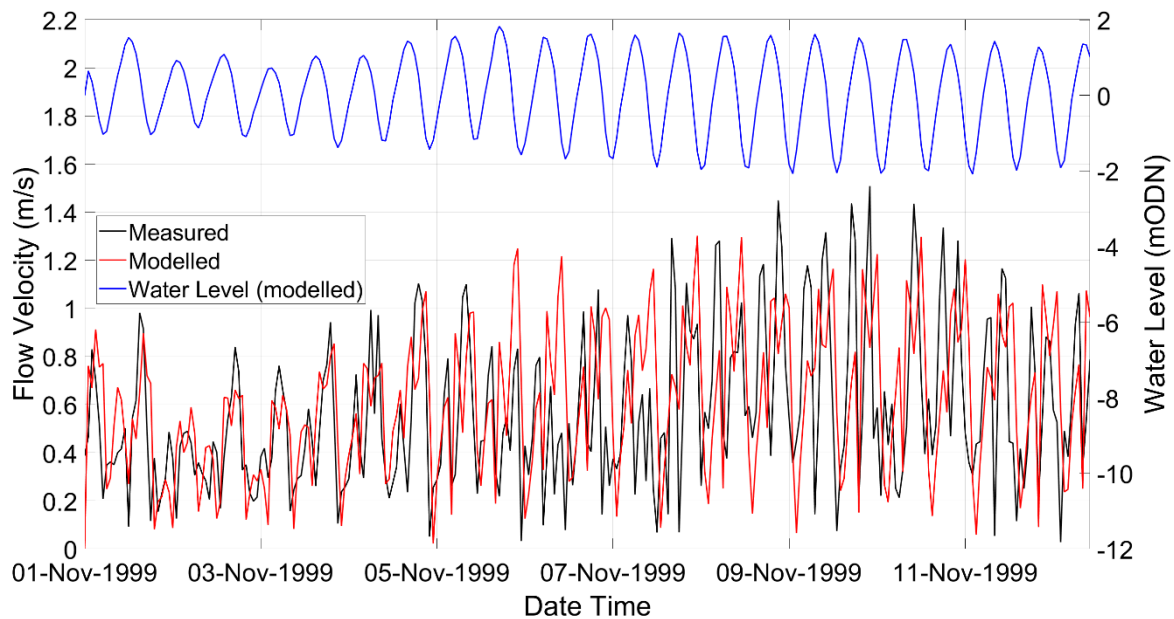

Figure C-7. Comparison between measured (black) and modelled (red) flow velocities in the Teign estuary. Blue line shows modelled water level during the simulation. Note that the bathymetric data used in this simulation was from 2018, while the flows were measured in 1999.

Additional calibration of the D-MORPHOLOGY sediment transport module was undertaken by varying morfac, sediment grain size and the sediment transport formula. The Soulsby-Van Rijn formula, applied in this research, is commonly utilized for predicting sediment transport in estuarine environments affected by both wave and current dynamics, such as in Knaapen and Joutstra (2012). Soulsby's adaptation integrates wave effects into the sediment transport formula, building upon Van Rijn (1993) which considered tidal currents alone without accounting for waves. Detailed description of the formula can be found in the Soulsby and Damgaard (2005, pp. 183-184) book 'Bedload sediment transport in coastal waters' (pages 183-184).

Validation of the predicted sediment transport was undertaken by comparing predicted morphological change from Delft3D-FM to measured morphological changes over the 21-month period from 14.05.2018 – 12.02.2020. Given the inherent challenges of morphological modelling, especially on coastlines affected by both estuarine and wave-driven flows, this aims to achieve qualitative agreement in the predicted morphological patterns and magnitude of change along Teignmouth Seafront Beach, with those measured by the two bathymetry datasets.

Figure C-8 illustrates a comparison between the measured and predicted bed level changes. This simulation includes 3 mm sediment size in the estuary and ebb-tidal delta and 1 mm sediment on the exposed frontage (Section C.4) and it was utilized as the primary representative run in this study. The model's projections for changes in the ebb-tidal delta indicate slightly higher magnitudes compared to the measured changes, with an exaggerated eroded area and sediment influx from the estuary, leading

to unrealistic accretion in front of the estuary. The absence of dredging in the model, in the area where sediment accumulates, likely contributes to these differences. On the Teignmouth frontage, the projected and observed deposition and erosion patterns qualitatively match, but more accretion is visible in the measured data, especially around Sprey Point, possibly due to the absence of dredge disposal in this simulation. The grain size of 3 mm (very fine gravel/granules) used in the estuary/ebb-tidal delta is at the absolute upper limit of what the Soulsby-Van Rijn equation is designed to simulate. The reasonable magnitudes of bed level changes in the ebb-shoal delta show that this limitation isn't having a significantly adverse effect on the results.

When dredging is included in the simulations, the validation against the observed morphological change improves slightly. The simulation with the maximum licenced dredge quantity shows improvement along the frontage, resulting in less erosion, which aligns better with observed data (Figure C-9). However, sediment accretion in front of Sprey Point due to dredge disposal is exaggerated in the model, as is erosion in the ebb-tidal delta due to the grab dredging. This may indicate that the dredging and disposal are performed over a wider area in reality than that used in the model, which would reduce the observed effect compared to the model, or that less than the full licenced amount is dredged/deposited annually (as estimated by ABPmer (2012b)). When the lower estimated dredge quantity is simulated, the dredging magnitudes are lessened in the model, although the level of accretion at the shoreline is still not fully reproduced (Figure C-10). However, the qualitative patterns of sediment accumulation and accretion better match the observed morphological changes.

The dredging simulations indicate that the optimal dredging quantity to simulate in the model falls somewhere between the maximum licenced dredge quantity and the lower estimated dredge quantity, but these two scenarios qualitatively reproduce the observed morphodynamic evolution and provide end-member predictions of the magnitudes of sedimentation occurring along the frontage and in the ebb-tidal delta under the existing grab dredging regime.

The model was successful in qualitatively capturing flow velocities and observed morphodynamic patterns and magnitudes of change, especially when dredging was included in the simulations. However, a high level of quantitative agreement was not achieved in either the flow comparison or the bed level change comparison. This is not surprising, given that concurrent flow measurements and bathymetry data were not available, and that there is a high degree of spatial variability in the sediment sizes across Teignmouth that cannot be spatially represented well, let alone implemented accurately in the model. Therefore, the model is deemed to be suitable for use in describing the approximate magnitudes of sediment fluxes (captured within the range of sediment classes tested), and in predicting relative changes in sedimentation by comparing different modelled scenarios.

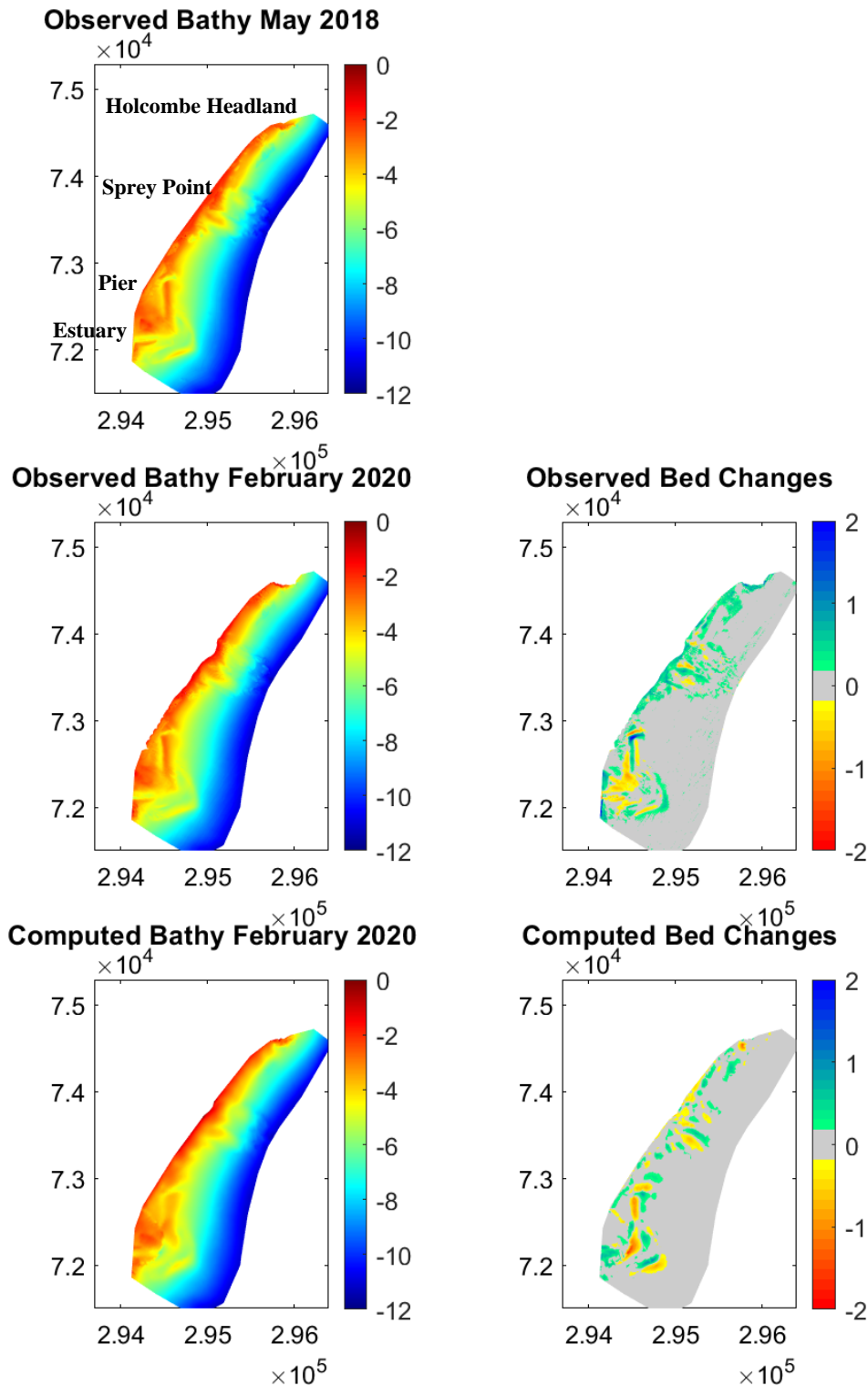

Figure C-8. Overview of observed and computed bed changes for the 3 mm/1 mm run (Section C.4) from May 2018 to February 2020. Upper panel shows measured bathymetry in May 2018. Middle panels illustrate measured bathymetry from 2020 (left) and measured bed changes (right). Lower panels show computed bed levels (left) and bed changes (right). No dredging was included in this simulation.

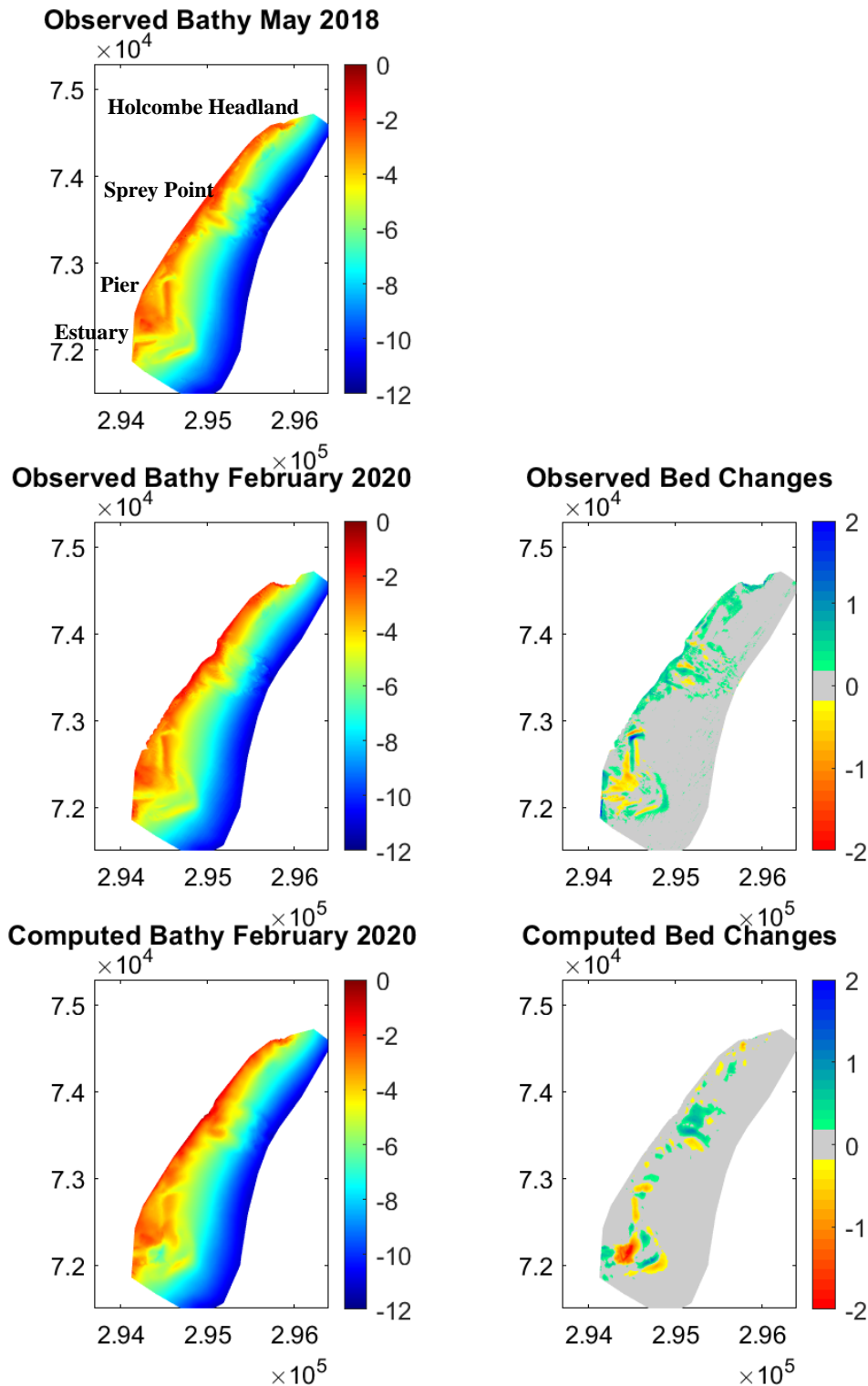

Figure C-9. Overview of observed and computed bed changes for the 3 mm/1 mm run (Section C.4) from May 2018 to February 2020. Upper panel shows measured bathymetry in May 2018. Middle panels illustrate measured bathymetry from 2020 (left) and measured bed changes (right). Lower panels show computed bed levels (left) and bed changes (right). The simulation includes the maximum licenced dredge quantity of 45,000 tonnes per year in the ebb-tidal delta and disposal of the same material quantity in front of Sprey Point.

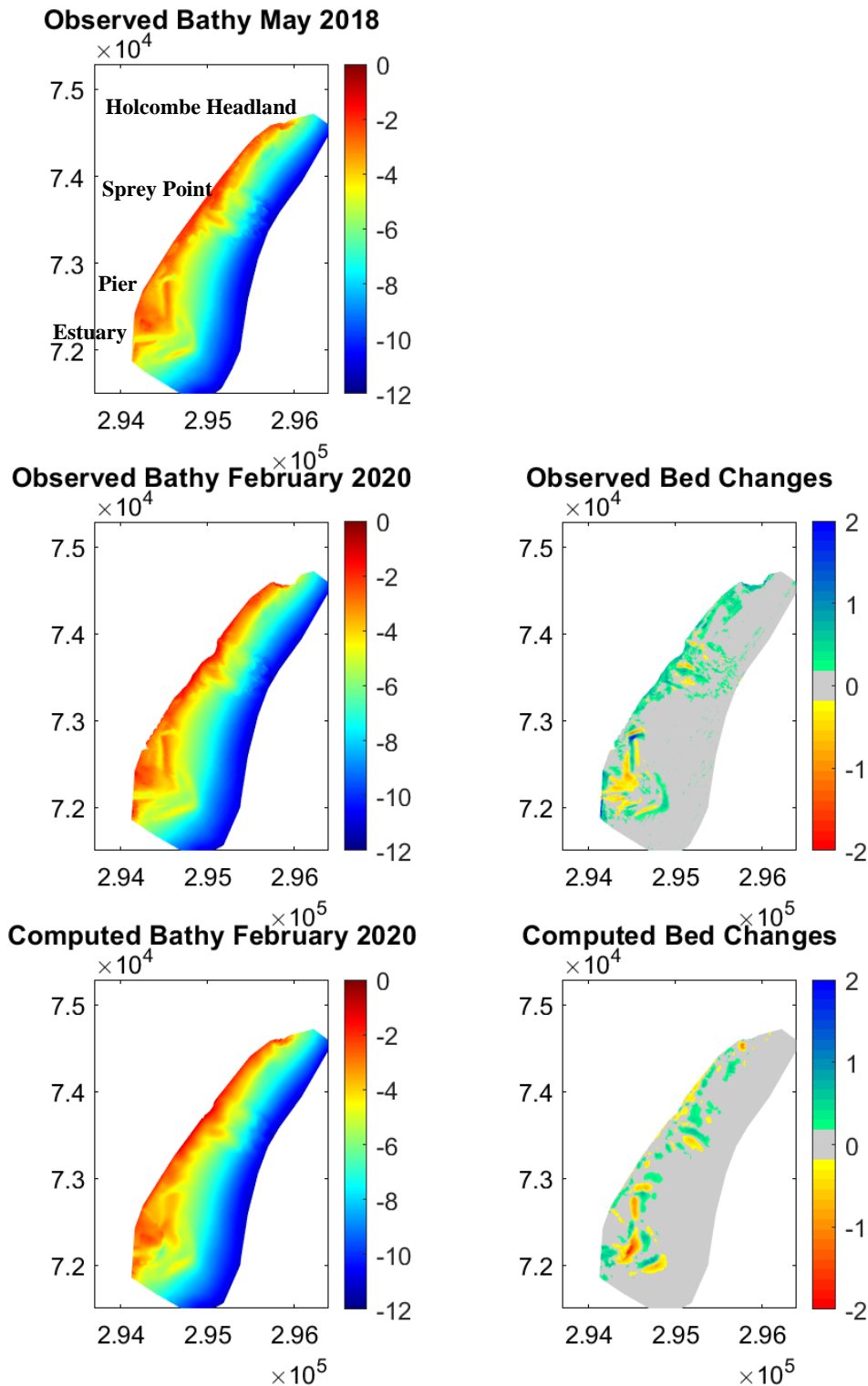

Figure C-10. Overview of observed and computed bed changes for the 3 mm/1 mm run (Section C.4) from May 2018 to February 2020. Upper panel shows measured bathymetry in May 2018. Middle panels illustrate measured bathymetry from 2020 (left) and measured bed changes (right). Lower panels show computed bed levels (left) and bed changes (right). The simulation includes the lower estimated dredge quantity of 15,000 tonnes per year in the ebb-tidal delta and disposal of the same material quantity in front of Sprey Point.

C.7 Model sensitivity analysis

C.7.1 Wave height

An analysis was undertaken to determine the sensitivity of modelled net sediment transport to different wave heights and wave periods. The purpose was to assess a suitable threshold wave height to use for the model forcing reduction technique described in Section C.5. This test was performed with 0.3 mm sediment size covering areas of the river delta, Shaldon Beach, Back Beach and Teignmouth Seafront Beach, which represents the finest grain sizes used in the modelling. Comparisons were made with a baseline run, which considered tides only, to determine the minimum wave height threshold that significantly contributes to sediment movement. Figure C-11 illustrates the outcomes of these sensitivity tests, indicating that generally, only waves >0.5 m contribute significantly to the net sediment transport rates. Therefore, this threshold was used for the forcing reduction technique described in Section C.5

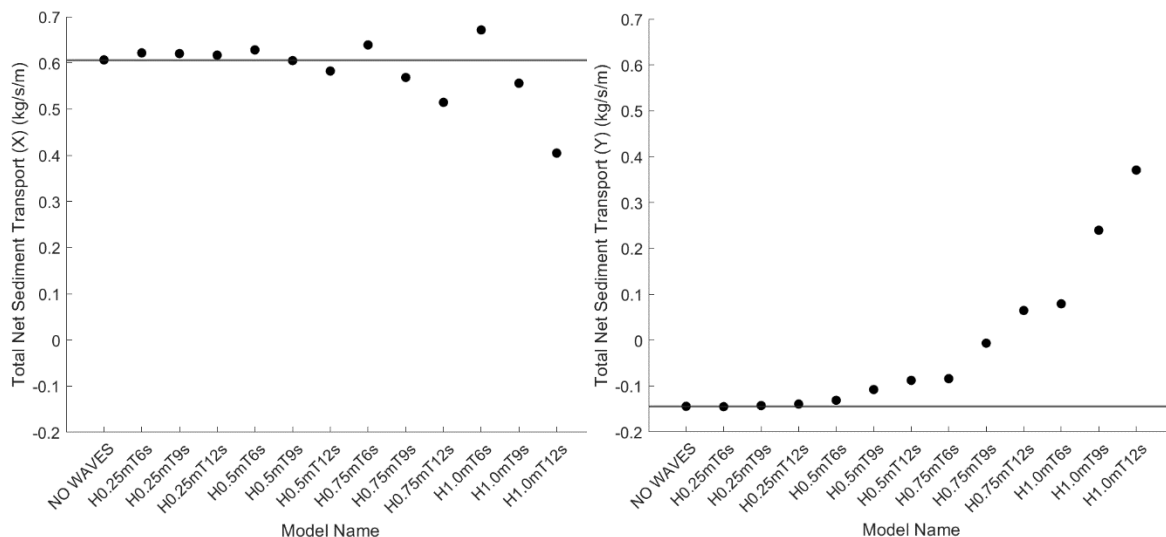

Figure C-11. Summary of wave height sensitivity analysis on net sediment transport. The Y axis displays the total net sediment transport for each simulation run while X axis represents various model runs under different forcing conditions. A horizontal line is included in the graph to depict the results from a tide only run, to help distinguish the influence of waves on sediment transport. The left panel shows net sediment transport in the x model direction (positive eastward) and the right panel shows net sediment transport in the y model direction (positive northward).

C.7.2 Sediment grain size

A sensitivity analysis was conducted for different sediment grain size. The primary sediment sizes used in the model are $D_{50} = 3$ mm in the estuary and ebb-tidal delta, and $D_{50} = 1$ mm on the exposed Seafront Beach (Section C.4). The validation of model runs using these sediment classes is presented in Section C.6 (Figure C-8, Figure C-9, Figure C-10). While these grain sizes are representative of the average measured values (Section 3.2), the sediment sizes in Teignmouth are highly heterogeneous, and finer

D_{50} values have been observed lower on the subtidal beach face and within the estuary/ebb-tidal delta than the primary values used in the model. Therefore, sensitivity tests were undertaken to better understand the upper bounds of the potential sediment fluxes using finer sediment sizes in the model.

In the first test, the estuary and ebb-shoal delta sediments were fixed at the average size (very coarse sand/fine gravel, $D_{50} = 3$ mm) while finer sediment was tested on the exposed frontage outside the ebb-tidal delta, characterized by medium sand ($D_{50} = 0.3$ mm). The two areas were divided as illustrated in Figure C-5. Comparison between observed and computed bed changes over the 21-month simulation period (Figure C-12) reveals significant overprediction of the magnitude of change and differences in the sedimentation patterns across the area. The model tended to amplify erosion and accretion in the ebb-tidal delta, leading to inaccurate predictions compared to the measured data. Also, the model predicts more erosion on the exposed beach frontage, despite the observed data indicating only accretion. Those outcomes indicate that the $D_{50} = 0.3$ mm grain size is too fine as a representative grain size for the exposed frontage but does provide a useful upper bound on the predicted transport fluxes outside the estuary.

In the second test, the sediments on the exposed frontage were fixed at the average representative size (coarse to very coarse sand; $D_{50} = 1$ mm), while finer than average grain size was used in the estuary and ebb-tidal delta (also coarse to very coarse sand; $D_{50} = 1$ mm). The results in Figure C-13 show generally closer agreement with the measured changes in comparison to the previous sensitivity simulation. However, overprediction of accretion still occurs in the ebb-shoal data, indicating that 1 mm grains are too fine for the estuary channels and ebb-tidal delta, as too much sediment is washed out of the estuary. Even if dredging had been included, the degree of sedimentation is too high. Furthermore, the 1 mm grains in the estuary resulted in unrealistically high morphodynamic change on The Salty, which is not visibly observed to change in size and geometry over the entire SWCMP monitoring period. Hence, the model run conducted with a sediment size of 3 mm in the estuary and ebb-shoal delta is considered more accurate in this regard. Along the exposed frontage, patterns of sedimentation in the sensitivity test with uniform 1 mm grain size throughout the domain are comparable to the primary model run, but this is unsurprising as both use 1 mm grain size on the exposed frontage.

The sensitivity tests confirm that the primary simulations using sediment sizes of $D_{50} = 3$ mm in the estuary/ebb-tidal delta and $D_{50} = 1$ mm on the exposed frontage best align with the observed sedimentation patterns. As a result, this simulation was selected to present the main results of the study.

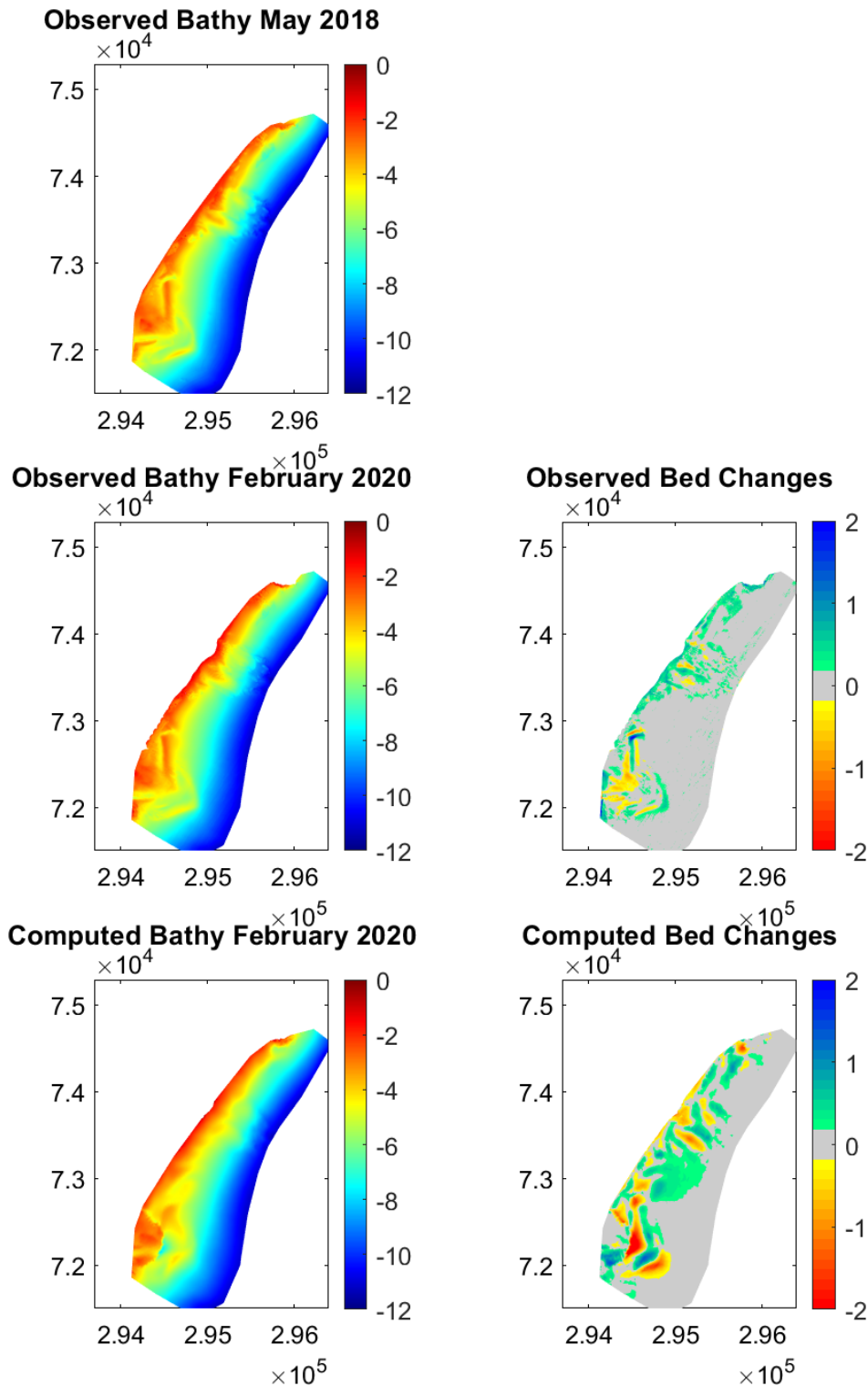

Figure C-12. Overview of observed and computed bed changes for the 3 mm/0.3 mm run (Section C.4) from May 2018 to February 2020. Upper panel shows measured bathymetry in May 2018. Middle panels illustrate measured bathymetry from 2020 (left) and measured bed changes (right). Lower panels show computed bed levels (left) and bed changes (right). No dredging was included in this simulation.

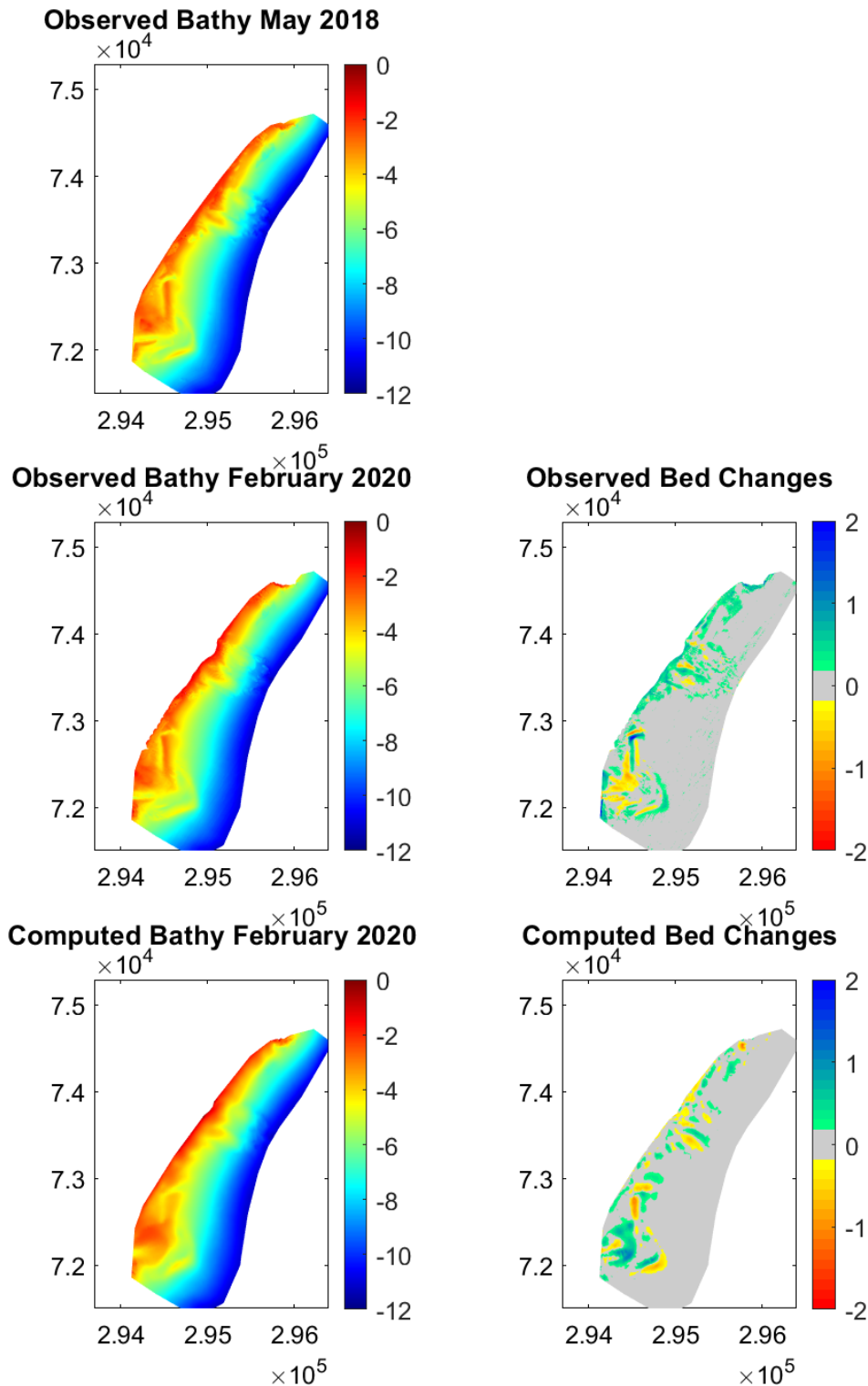

Figure C-13. Overview of observed and computed bed changes for the uniform 1 mm run (Section C.4) from May 2018 to February 2020. Upper panel shows measured bathymetry in May 2018. Middle panels illustrate measured bathymetry from 2020 (left) and measured bed changes (right). Lower panels show computed bed levels (left) and bed changes (right). No dredging was included in this simulation.

C.8 Modelled engineered structures

There are numerous sea defence structures along the Teignmouth frontage. Within the Delft3DFM model, the following structures were implemented in the model:

- **All seawalls within the region of interest** were implemented as dry areas which act as an infinitely high wall, blocking flows and sediment transport.
- **The terminal groyne on Denn Spit and submerged armoured structure adjacent to Shaldon Beach** were implemented in the model with an appropriate height and geometry, based on bathymetric/Lidar measurements.
- **Shaldon bridge walls.** At either side of the estuary, Shaldon bridge has solid wall structures that support the start and end of the bridge. These were implemented in the model as dry areas. They therefore act to completely block flows and sediment transport where the walls are present. The open span of the bridge beyond the walls, including the pillars of the bridge, were not implemented in the model (see below).

Structures that weren't included in the model are:

- **The existing timber groyne field** along the frontage. While it is acknowledged that these structures do affect flows and sediment transport to some degree (which is evidenced by slightly different shoreline positions visible either side of many of the groynes), a means to accurately define their efficacy at blocking sediment transport does not exist. Furthermore, structures with partial permeability to sediment transport cannot be implemented in Delft3D. Therefore, they are not included in the model. Due to the poor state of most of the timber groynes, it is estimated that they would alter the predicted fluxes by no more than 20%.
- **The pier.** It is assumed that the pillars of the pier only have a localised effect on flows (e.g. through increased turbulence) and sedimentation (e.g. through localised scour and deposition patterns), and are therefore not included in the model. This is supported by the fact that significant differences in shoreline position are not noticeable updrift/downdrift of the pier.
- **Shaldon bridge pillars.** It is assumed that the pillars of the bridge only have a localised effect on flows (e.g. through increased turbulence) and sedimentation (e.g. through localised scour and deposition patterns), and are therefore not included in the model. This is supported by the fact that only localised patterns of sedimentation are noticeable updrift/downdrift of the pillars.

C.9 Delft3D-FM assumptions and limitations

The Delft3D-FM hydrodynamic and sediment transport model employed in this study is underpinned by several key assumptions and limitations.

- The **depth of erodible sediment** is not accurately known for most of the frontage, and the location of exposed bedrock was only included in the model where it is known to exist at the bounding headlands and in the main estuary inlet channel. This introduces some uncertainties due to the lack of comprehensive information on sediment availability throughout the domain but is a common and necessary simplification of reality. While exposed bedrock is known to exist in the deepest section of the estuary inlet channel, its exact spatial extent is not well defined and needed to be estimated. Also, to limit sediment erosion around headlands, exposed bedrock was implemented where it is visible from satellite images in Google Earth.
- The **spatial distribution of sediment** is simplified into two primary sediment classes, which does not fully capture the complexity of sediment variability at Teignmouth, where a spectrum of heterogeneous sediment sizes exists. The spatial areas of the two different sediment classes were estimated based on quantitative sediment samples from the 1999 Coast3d project and the 2018 SWRRP project, as well as qualitative sediment classification conducted in 2023 for the SWCMP.
- The **exclusion of timber groynes** from the model. While some groynes appear to slightly alter the shoreline position, many are in poor condition, making it challenging to quantify their impact on sediment fluxes accurately. Because of this, and because the model cannot account for partial permeability, the groynes were excluded (apart from the concrete terminal groyne on Denn Spit).
- The **estimation of dredging and dumping locations**, as well as the size of the area, was derived from a sediment re-nourishment study conducted by ABPmer (2012). It was assumed that dredging and dumping occur continuously at an average rate, unlike in reality.
- **Compression and acceleration of wave forcing** through the morphodynamic acceleration techniques described in Section C.5 requires that tidal forcing remains uncompressed, This assumes that tidal phasing in relation to the waves is relatively unimportant, and that the time scale of the tides can be decoupled from the time scale of the waves and morphology.

The model was successful in qualitatively capturing observed morphodynamic patterns and magnitudes of change, especially when dredging was included in the simulations, and this provides some confidence that the above listed assumptions do not significantly impact on the conclusions drawn from the modelling.

Appendix D Future beach evolution modelling using ShoreTrans

D.1 ShoreTrans model description

To investigate the potential future response of Teignmouth's beaches to rising sea level, The ShoreTrans model was used (McCarroll et al., 2021). This model uses a similar approach to the classical 'Bruun Rule' (Bruun, 1954, 1962, 1988), in that the beach profile is assumed to translate upwards and shoreward as sea level rises (Figure A-4), maintaining the same overall equilibrium profile and beach width. However, ShoreTrans deals with a number of the shortcomings of the Bruun Rule (Cooper & Pilkey, 2004); in particular, sediment supply factors such as the depth of erodible sediment, long-term trends in alongshore sediment supply, and short-term storm erosion demand can all be taken into consideration. Of relevance to Teignmouth, ShoreTrans also allows for consideration of the presence of a seawall on the profile (Appendix A), and therefore makes an estimation of the potential for future coastal squeeze.

ShoreTrans is a profile response model, meaning that the beach is considered in two-dimensions only, with the cross-sectional profile adjusted according to the projected sea level rise as well as any annual trend in the alongshore sediment supply. Coastal squeeze is represented using the assumptions described in Appendix A, whereby erosion demand denied by the presence of a seawall is satisfied through the removal of sediment in front of the wall. The volume of erosion denied by the seawall depends on the seawall's cross-shore position and the amount of sea level rise. This erosion volume is then translated in front of the seawall by lowering the first one-third of the active beach profile by an equivalent volume, following the laboratory results of Beuzen et al. (2018). Beuzen et al. (2018).

D.2 ShoreTrans model setup

D.2.1 ShoreTrans input variables

There are several inputs to ShoreTrans that can be adjusted, including:

- The beach profile (either a snapshot in time, or a time-averaged profile)
- Amount and rate of sea level rise
- Long-term trends in local sediment supply (gains/losses)
- Depth of closure
- Width of beach face affected by wall-induced erosion demand (Appendix A)

Each of the above inputs has some uncertainty associated with it. For example, the amount of future sea level rise has a quantified range of uncertainty as predicted by UKCP18, even for a single emissions scenario. Equally, trends in local sediment supply can be quantified from monitoring measurements made over recent decades, but there is uncertainty around how these trends may vary over the next

century. To deal with such uncertainties, a monte-carlo approach was used when projecting the future profile shape using ShoreTrans. 1000 different predictions were made for each profile with the inputs perturbed around their expected values, providing a range of possible future profile shapes, from which the most likely (50th percentile) profile can be drawn, as well as upper and lower confidence bounds (5th and 95th percentiles). Following the approach of McCarroll et al. (2021) Following the approach of McCarroll et al. (2021), the values provided to ShoreTrans at each model iteration were drawn from distributions fitted to each variable (described in Table D-1) that represent the likely range of values that could occur. For example, the sediment supply trend provided to ShoreTrans at each profile was drawn from a triangular distribution, where the central value is the observed trend, and the lower and upper ranges of the distribution are the observed trend plus/minus 50%, respectively (Figure D-1).

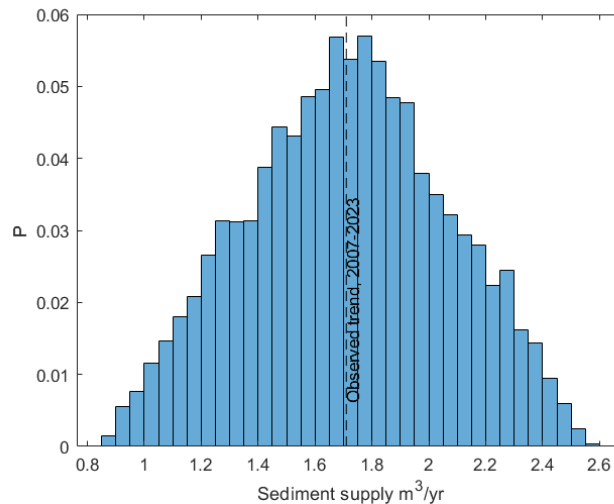

Figure D-1. Example of random values pulled from a triangular distribution used for the monte-carlo ShoreTrans modelling. This example distribution describes the rate of expected annual sediment gain/loss at a profile along Teignmouth seafront, with the central value (dashed black line) the observed annual sediment gain/loss at that location, while the upper and lower bounds of the distribution extend to +/- 50% of the observed trend (Table D-1).

Table D-1. ShoreTrans input variables and distributions used to account for uncertainty in the input values.

Input variable	Fixed or variable?	Distribution type	Median value	Lower value	Upper value
-----------------------	---------------------------	--------------------------	---------------------	--------------------	--------------------

<i>Beach profile</i>	Fixed (see section below)	-	-	-	-
<i>Sea level rise</i>	Variable	UKCP18, RCP8.5 scenario	From UKCP18 distribution	From UKCP18 distribution	From UKCP18 distribution
<i>Sediment supply trend</i>	Variable	Triangular	Observed SWCMP volume trend	Observed trend -50%	Observed trend +50%
<i>Depth of closure (DoC)</i>	Variable	Triangular	Computed DoC	Computed DoC -50%	Computed DoC +50%
<i>Seawall erosion width</i>	Variable	Triangular	1/3 of active profile width	1/4 of active profile width	1/2 of active profile width

D.2.2 Depth of erodible sediment

The depth of erodible sediment above the underlying bed rock can be included in ShoreTrans, which helps account for situations where shallow bed rock will limit the amount of sediment available for future profile adjustment. Ground Investigation (GI) data are available at various locations in Teignmouth, although relatively few cores are available from the beach face to describe the depth of sediment. Furthermore, most GI boreholes conducted in Teignmouth have been limited to less 10 m below ground level and most do not reach a consolidated bed rock layer. However, three boreholes drilled in 1969 prior to seawall improvement works along the seafront beach (Figure D-2) reached a sandstone bed rock layer at an elevation of 22.5-23 m below ODN, above which layers of red marl, clay, silt, gravel and sand are apparent. The depth of bed rock measured at these locations indicates that bed rock will not influence future sediment availability along the main seafront beach and can therefore be disregarded for some profiles in ShoreTrans.

However, bed rock does protrude the beach surface in a number of locations along the frontage of the railway line; in particular, adjacent to Sprey Point and immediately south of Holcombe headland. This was visible during site inspections and from aerial images, as well as in measured bathymetric profiles, appearing as an area of high surface roughness between approximately -2 to -6 mODN. Although the full extent of this bed rock layer cannot be described adequately due to a lack of geophysical data, it can be prescribed in ShoreTrans over the areas where it visibly protrudes from the seabed. Partial bed rock layers were therefore implemented in ShoreTrans for SWCMP profiles 6b00157, 6b00161, 6b00172, 6b00179, 6b00183, 6b00187, and 6b00191 (see Figure 4-1.) where bed rock could be confidently identified in the bathymetric data.

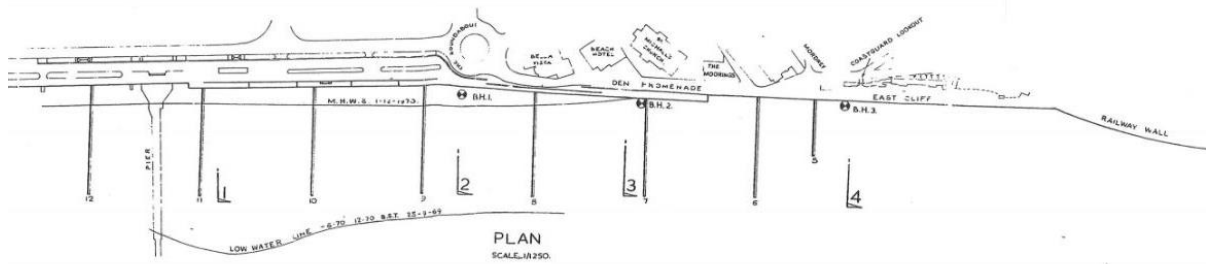

Figure D-2. Borehole locations (BH 1, BH 2, BH 3) taken in 1969 by Lewis & Duvivier Consulting Engineers along Teignmouth’s seafront beach.

D.2.3 Projected profiles

Future projections were made at each of the SWCMP interim profile locations on Teignmouth’s Seafront Beach, Teignmouth Back Beach, and Shaldon Beach (see Figure 4-1.). A measured beach profile was used at each location, representing the beach at the year 2020. This profile was extracted from SWCMP LiDAR data and multibeam bathymetry data collected in the summer of 2020, which were merged to make a single profile extending landwards of the seawall out to a depth typically below -15 m ODN (i.e., well beyond the depth of closure) along the seafront beach. A time-averaged profile was considered instead, as a single measured profile represents only a snapshot in time. However, averaging profiles across multiple years doesn’t necessarily achieve a realistic equilibrium profile shape, especially where a long-term erosive or accretive trend is occurring, which is the case along Teignmouth’s seafront beach. Therefore, it is assumed that the profiles used represent an equilibrium summer beach profile. The future predicted profiles therefore also represent a summer profile shape.

ShoreTrans follows the Bruun Rule to assess the potential future recession due to SLR. A critical input to this is the selection of the active profile, as the slope of the active profile determines the predicted horizontal recession. The active profile is typically defined at its lower extent by the DoC and at its upper extent the berm or foredune height (Figure A-4). In this study we use two distinct methods to define the lower extent of the active profile, in recognition of the fact that wave driven processes dominate on the Seafront Beach, while tidal processes and only modest fetch-limited waves operate on the estuary beaches:

- For exposed profiles on the Seafront Beach, three empirical equations that compute DoC from the observed wave record (Birkemeier, 1985; Capobianco et al., 1997; Hallermeier, 1980) were used to calculate the DoC, with the final DoC taken as the average of the three estimates.
- For the sheltered beaches within the estuary (Shaldon and Teignmouth Back Beach), Mean Low Water elevation is used as the Depth of Closure, as tidal excursion and small fetch limited waves determine the active beach slope.

This approach follows several other studies of enclosed embayments, estuaries and other low-energy coastal environments that have applied Bruun Rule based approaches to predict coastal evolution (Stevens, 2010; Tonkin & Taylor, 2017; Water Technology, 2022, 2023).

D.2.4 ShoreTrans assumptions and limitations

The ShoreTrans model uses the following assumptions (McCarroll et al., 2021):

- The profile shape is translated upward and landward in response to sea-level rise, assuming the equilibrium shape remains unchanged. Material eroded from the upper beach is balanced by deposition on the lower beach (i.e. the basic assumptions of the Bruun Rule).
- Where a seawall exists on the profile, beach lowering is estimated using the wall erosion demand assumption (Appendix A). This volume is distributed in front of the wall in a triangular wedge, with maximum eroded volume at the base of the wall, linearly tapering to zero at a specified distance from the wall (See Table D-1).
- Total profile volume is conserved in all cases, apart from cases where a sediment supply trend is specified as an input (See Table D-1).

In addition to these assumptions that underpin ShoreTrans, further optional assumptions have been made:

- Storm cut and fill (i.e. even scale cross-shore transport) is not provided as an additional input to ShoreTrans in this study because cross-shore transport can be assumed to average out over the long term (i.e. storm/recovery cycle balances). Instead, the two dominant storm wave directions are assumed to primarily drive littoral drift, which is accounted for in the observed sediment supply trends provided to ShoreTrans.
- The profiles used are assumed to represent an equilibrium summer beach profile.
- ShoreTrans was run with and without existing sediment volume trends included, to provide comparison. Sediment trends have a significant effect on the predicted profile shape and elevation, controlling whether a profile will retreat or prograde over the long-term. It is highly uncertain whether existing sediment trends will continue to the year 2120, but extrapolating measured trends is one of the few methods available to estimate potential future sediment gains and losses along the frontage.
- Where visible bed rock occurs, these layers are assumed to extend horizontally at the highest visible elevation, providing a theoretical minimum beach level.
- Where severe beach lowering is predicted, this is limited to an elevation equivalent to the theoretical Depth of Closure.

The following limitations to this approach are recognised:

- The profile volume trends are derived from topographic measurements, which are limited to elevations above mean low water spring (MLWS) elevation. Therefore, these trends only describe part of the total net annual sediment change at each location. By necessity, the ShoreTrans predictions therefore assume that profile volume trends between MLWS (-2 mODN) and depth of closure (-5.4 mODN) are negligible, although this may not be true in reality.
- On Teignmouth Back Beach and Shaldon Beach, changes in tidal currents through the estuary are likely to be a significant factor as sea levels rise and may potentially alter the morphology of the estuary beaches significantly. As there is no reliable way to model this over a century timescale, it has been disregarded in the present analysis.

D.2.5 Model calibration and validation

The ShoreTrans model is calibrated at each location by having a relevant input profile, a quantified sediment supply trend, a computed DoC, and a local SLR projection. The Bruun Rule combined with aspects of the sediment budget that are included in ShoreTrans have been validated to some degree in previous studies (Robert George Dean & Houston, 2016; Zhang, Douglas, & Leatherman, 2004), and are supported by geological evidence (Fruergaard et al., 2015; Fruergaard, Sander, Goslin, & Andersen, 2021; Kinsela, Daley, & Cowell, 2016). However, while the mechanisms have been verified in a conceptual sense against observations, higher levels of sea level rise would be required to achieve a robust validation against observations. This is because, over the period of available topographic measurements, any existing SLR response cannot be reliably separated from other shoreline changes (for example, storm response) because the inter-annual variation in the profiles due to storm response and alongshore sediment transport gradients is high relative to the modest amount of total SLR over the available measurement period.

For this reason, it is not possible to perform a validation of the future profile evolution at this specific study site against measurement data. Rather, the ShoreTrans projections provide estimates of possible outcomes of sea level rise combined with extrapolation of current sediment supply trends, using the best available assumptions about future beach response and coastal squeeze.

D.3 ShoreTrans results figures

D.3.1 Teignmouth Seafront Beach

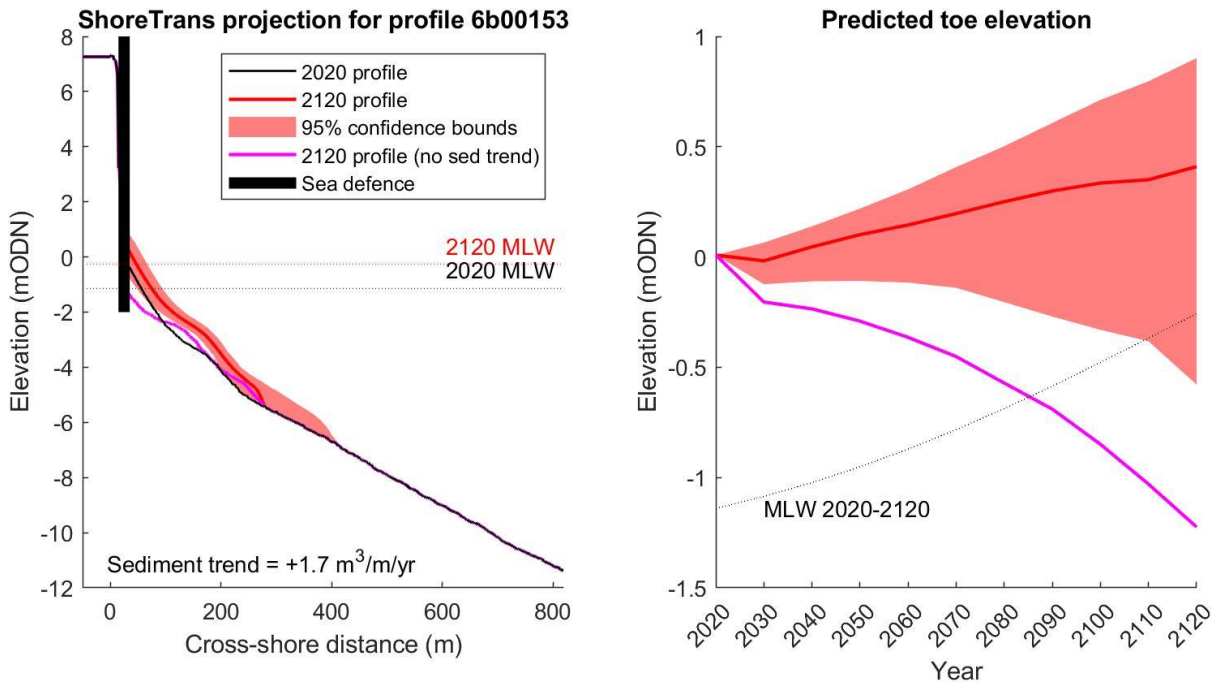

Figure D-3. ShoreTrans results for profile 6b00153 on Teignmouth’s Seafront Beach. Left: predicted cross-sectional profile evolution between 2020 and 2120. Right: predicted beach elevation at the toe of the seawall over time. Results are shown with (red) and without (magenta) inclusion of existing sediment supply trends. Mean Low Water (MLW) elevation is shown for reference. The sea defence cross-shore position is indicated, but toe depth is unknown.

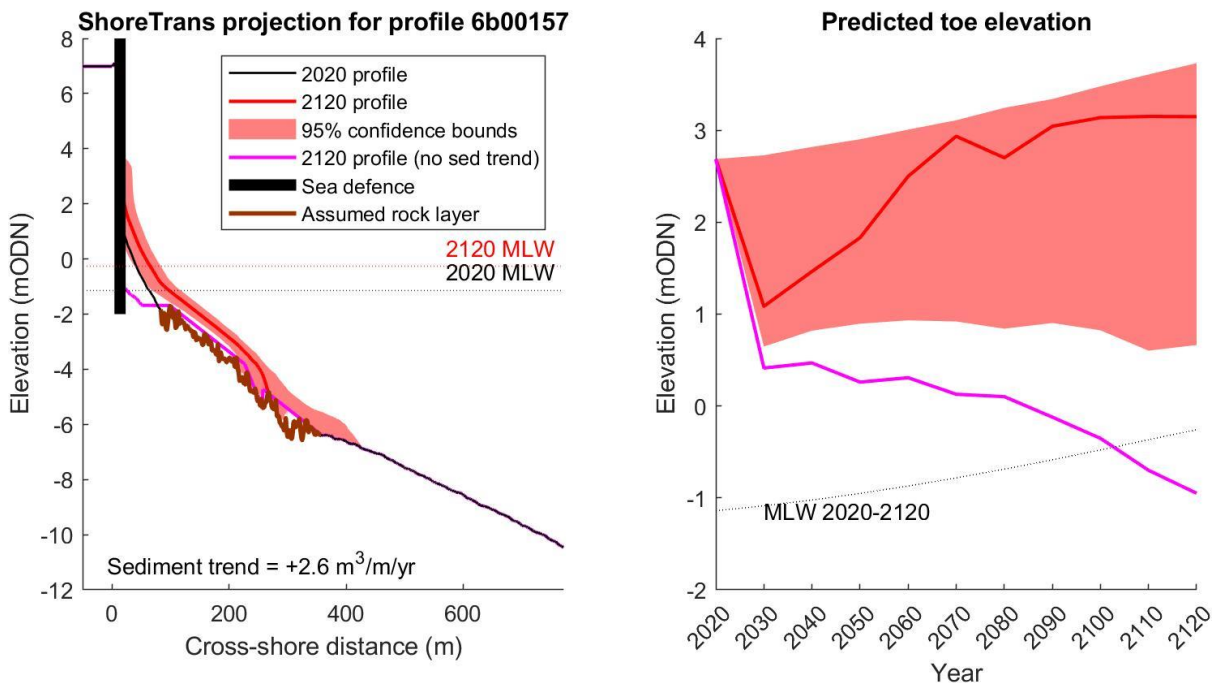

Figure D-4. ShoreTrans results for profile 6b00157 on Teignmouth’s Seafront Beach. Left: predicted cross-sectional profile evolution between 2020 and 2120. Right: predicted beach elevation at the toe of the seawall over time. Results are shown with (red) and without (magenta) inclusion of existing sediment supply trends. Mean Low Water (MLW) elevation is shown for reference. The sea defence cross-shore position is indicated, but toe depth is unknown.

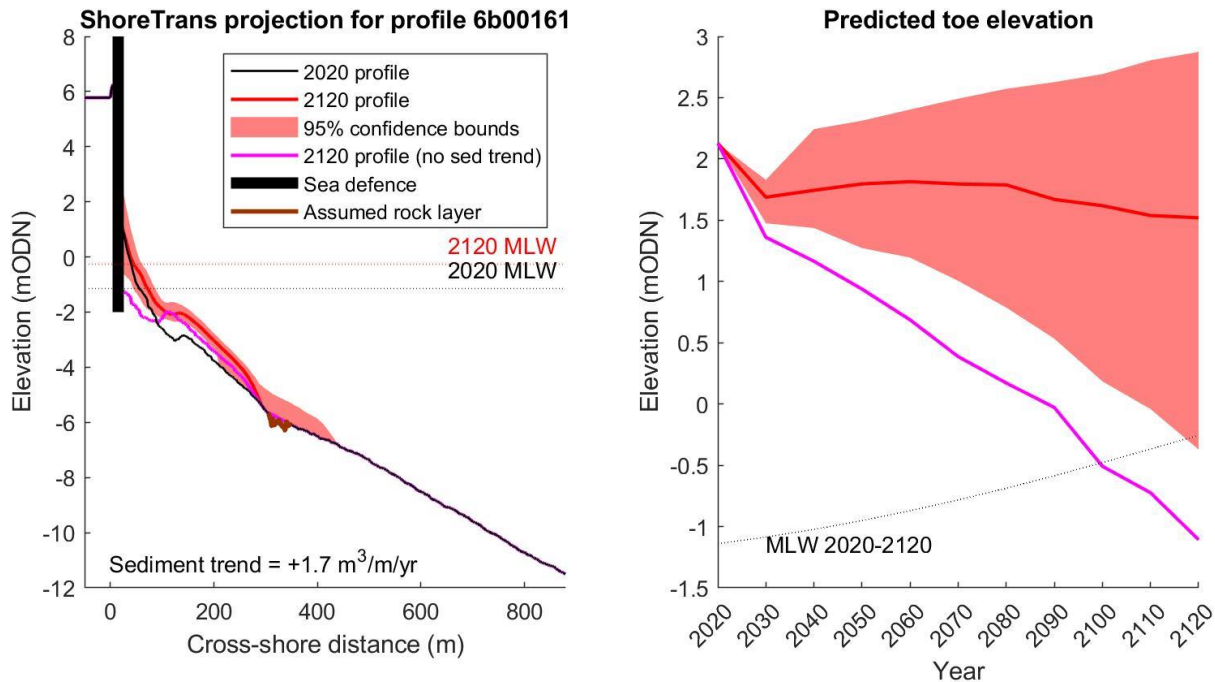

Figure D-5. ShoreTrans results for profile 6b00161 on Teignmouth’s Seafont Beach. Left: predicted cross-sectional profile evolution between 2020 and 2120. Right: predicted beach elevation at the toe of the seawall over time. Results are shown with (red) and without (magenta) inclusion of existing sediment supply trends. Mean Low Water (MLW) elevation is shown for reference. The sea defence cross-shore position is indicated, but toe depth is unknown.

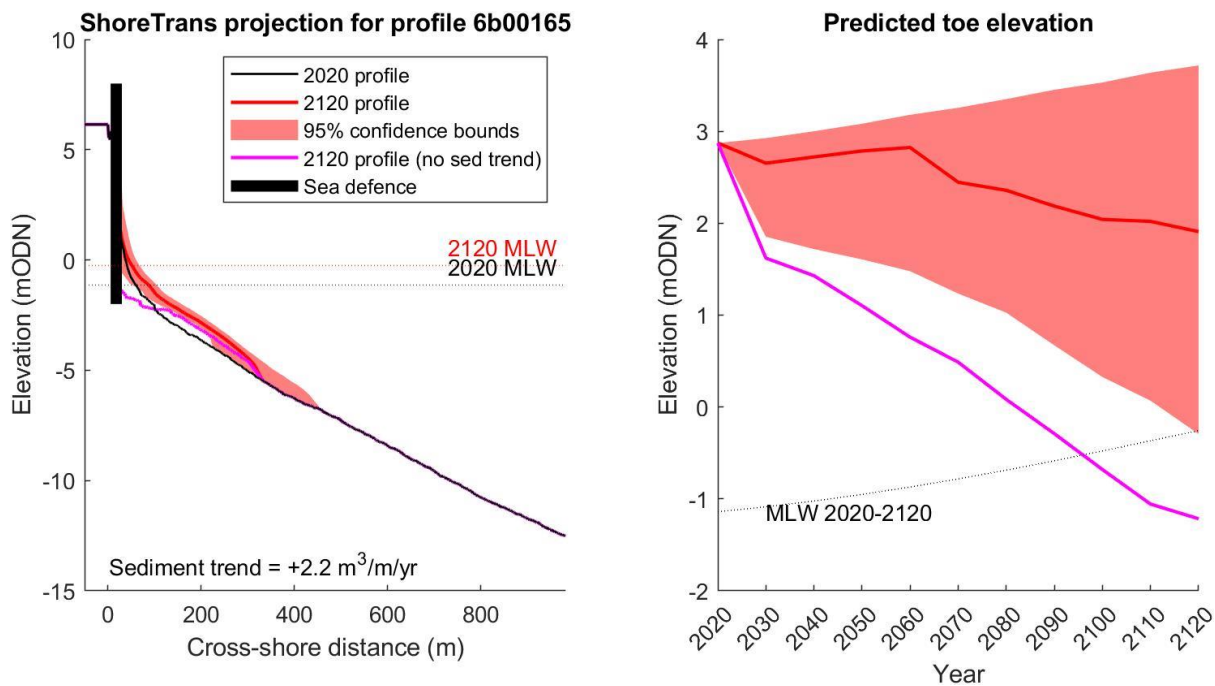

Figure D-6. ShoreTrans results for profile 6b00165 on Teignmouth’s Seafont Beach. Left: predicted cross-sectional profile evolution between 2020 and 2120. Right: predicted beach elevation at the toe of the seawall over time. Results are shown with (red) and without (magenta) inclusion of existing sediment supply trends. Mean Low Water (MLW) elevation is shown for reference. The sea defence cross-shore position is indicated, but toe depth is unknown.

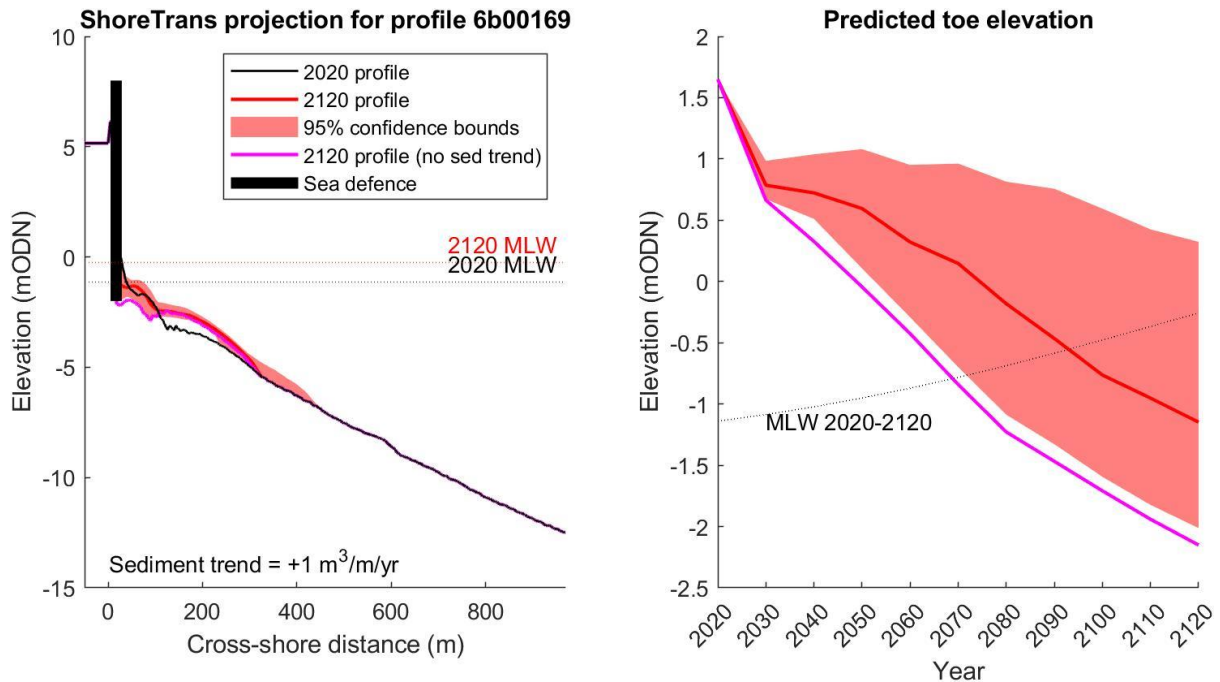

Figure D-7. ShoreTrans results for profile 6b00169 on Teignmouth’s Seafrent Beach. Left: predicted cross-sectional profile evolution between 2020 and 2120. Right: predicted beach elevation at the toe of the seawall over time. Results are shown with (red) and without (magenta) inclusion of existing sediment supply trends. Mean Low Water (MLW) elevation is shown for reference. The sea defence cross-shore position is indicated, but toe depth is unknown.

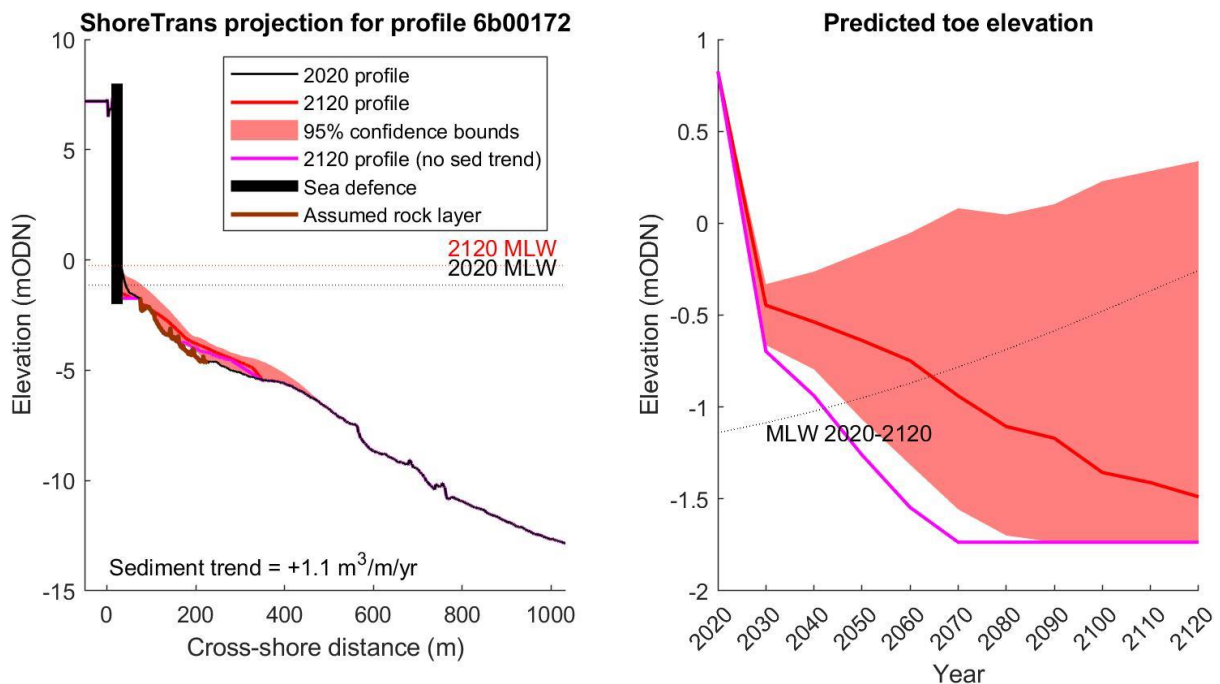

Figure D-8. ShoreTrans results for profile 6b00172 on Teignmouth’s Seafrent Beach. Left: predicted cross-sectional profile evolution between 2020 and 2120. Right: predicted beach elevation at the toe of the seawall over time. Results are shown with (red) and without (magenta) inclusion of existing sediment supply trends. Mean Low Water (MLW) elevation is shown for reference. The sea defence cross-shore position is indicated, but toe depth is unknown.

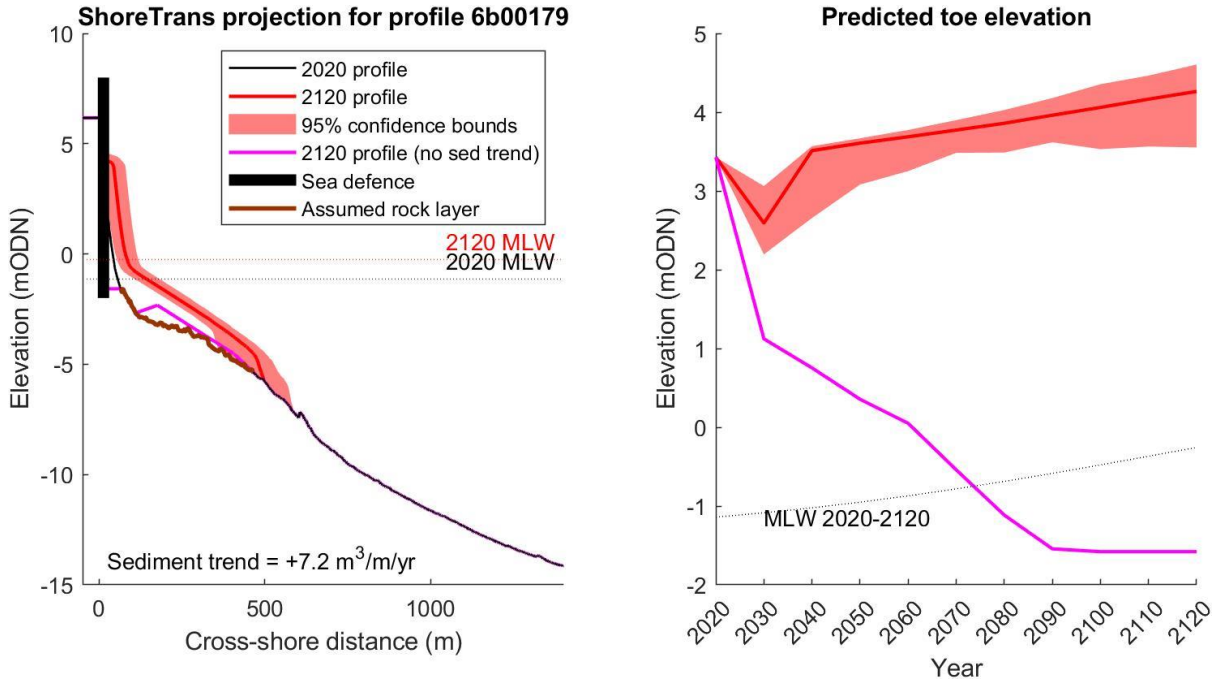

Figure D-9. ShoreTrans results for profile 6b00179 on Teignmouth’s Seafront Beach. Left: predicted cross-sectional profile evolution between 2020 and 2120. Right: predicted beach elevation at the toe of the seawall over time. Results are shown with (red) and without (magenta) inclusion of existing sediment supply trends. Mean Low Water (MLW) elevation is shown for reference. The sea defence cross-shore position is indicated, but toe depth is unknown.

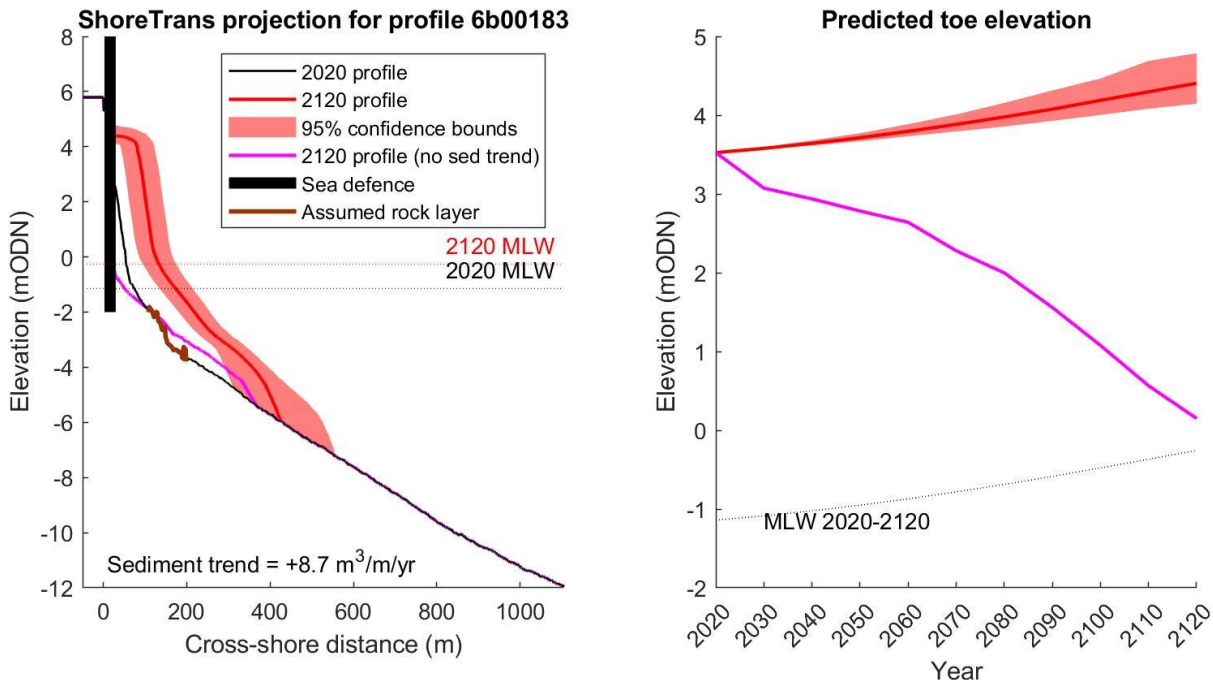

Figure D-10. ShoreTrans results for profile 6b00183 on Teignmouth’s Seafront Beach. Left: predicted cross-sectional profile evolution between 2020 and 2120. Right: predicted beach elevation at the toe of the seawall over time. Results are shown with (red) and without (magenta) inclusion of existing sediment supply trends. Mean Low Water (MLW) elevation is shown for reference. The sea defence cross-shore position is indicated, but toe depth is unknown.

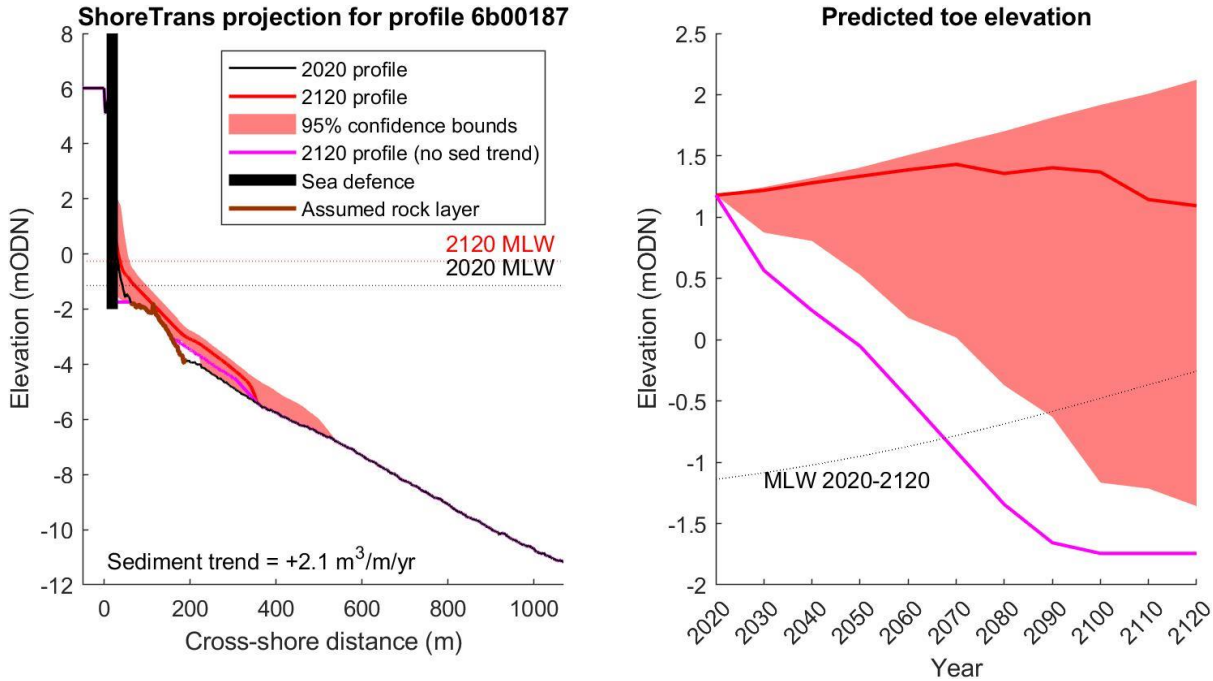

Figure D-11. ShoreTrans results for profile 6b00187 on Teignmouth’s Seafront Beach. Left: predicted cross-sectional profile evolution between 2020 and 2120. Right: predicted beach elevation at the toe of the seawall over time. Results are shown with (red) and without (magenta) inclusion of existing sediment supply trends. Mean Low Water (MLW) elevation is shown for reference. The sea defence cross-shore position is indicated, but toe depth is unknown.

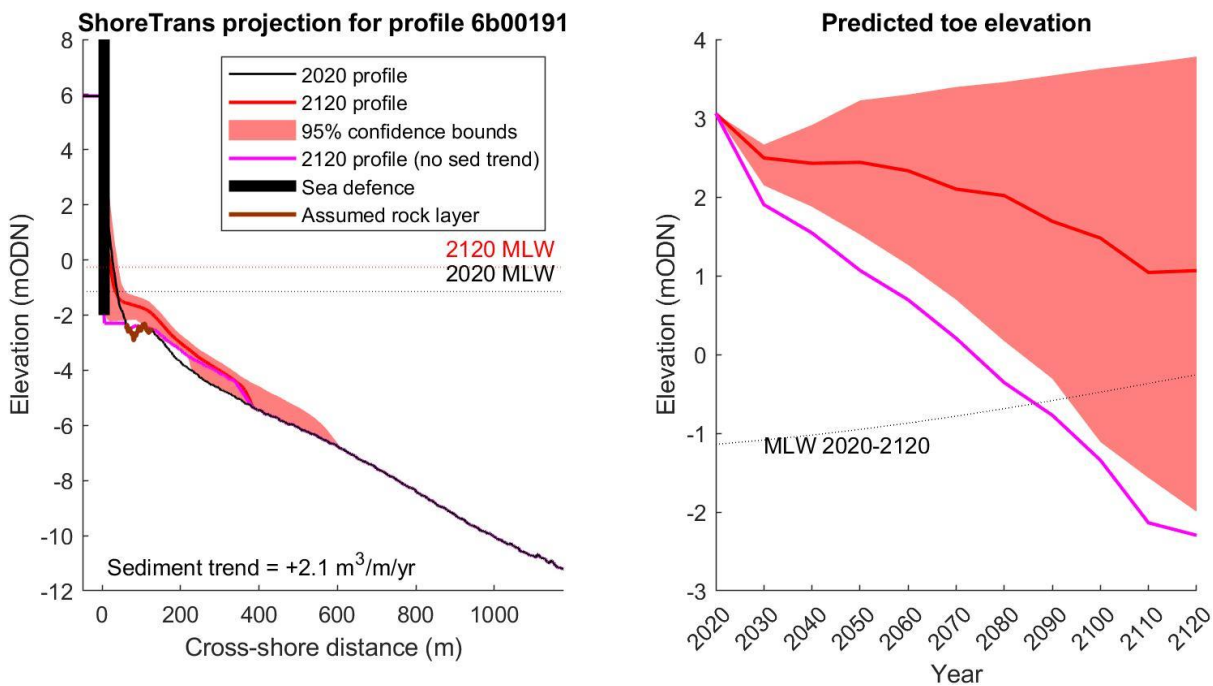

Figure D-12. ShoreTrans results for profile 6b00191 on Teignmouth’s Seafront Beach. Left: predicted cross-sectional profile evolution between 2020 and 2120. Right: predicted beach elevation at the toe of the seawall over time. Results are shown with (red) and without (magenta) inclusion of existing sediment supply trends. Mean Low Water (MLW) elevation is shown for reference. The sea defence cross-shore position is indicated, but toe depth is unknown.

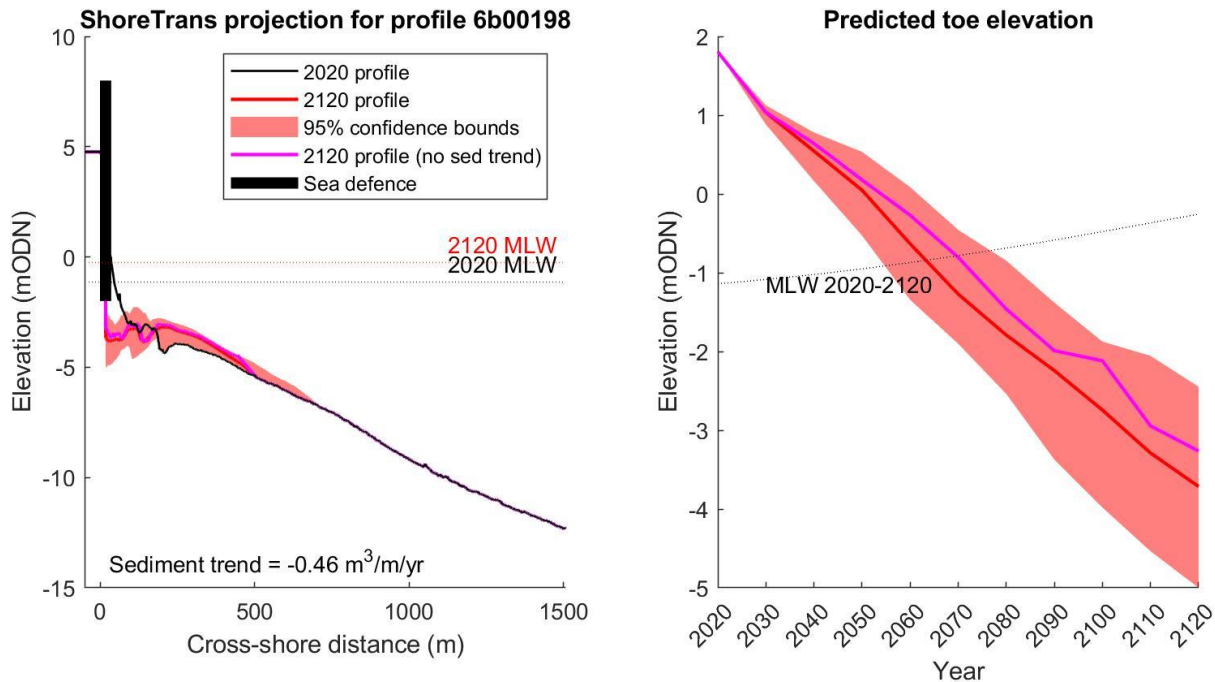

Figure D-13. ShoreTrans results for profile 6b00198 on Teignmouth’s Seafront Beach. Left: predicted cross-sectional profile evolution between 2020 and 2120. Right: predicted beach elevation at the toe of the seawall over time. Results are shown with (red) and without (magenta) inclusion of existing sediment supply trends. Mean Low Water (MLW) elevation is shown for reference. The sea defence cross-shore position is indicated, but toe depth is unknown.

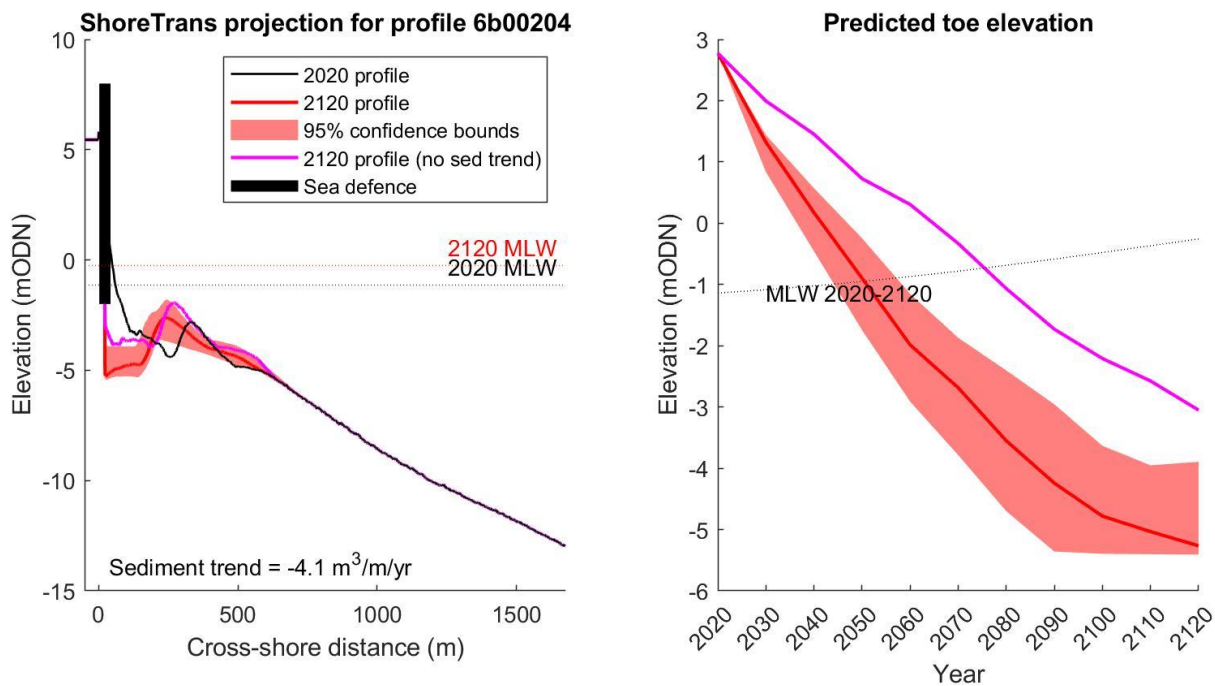

Figure D-14. ShoreTrans results for profile 6b00204 on Teignmouth’s Seafront Beach. Left: predicted cross-sectional profile evolution between 2020 and 2120. Right: predicted beach elevation at the toe of the seawall over time. Results are shown with (red) and without (magenta) inclusion of existing sediment supply trends. Mean Low Water (MLW) elevation is shown for reference. The sea defence cross-shore position is indicated, but toe depth is unknown.

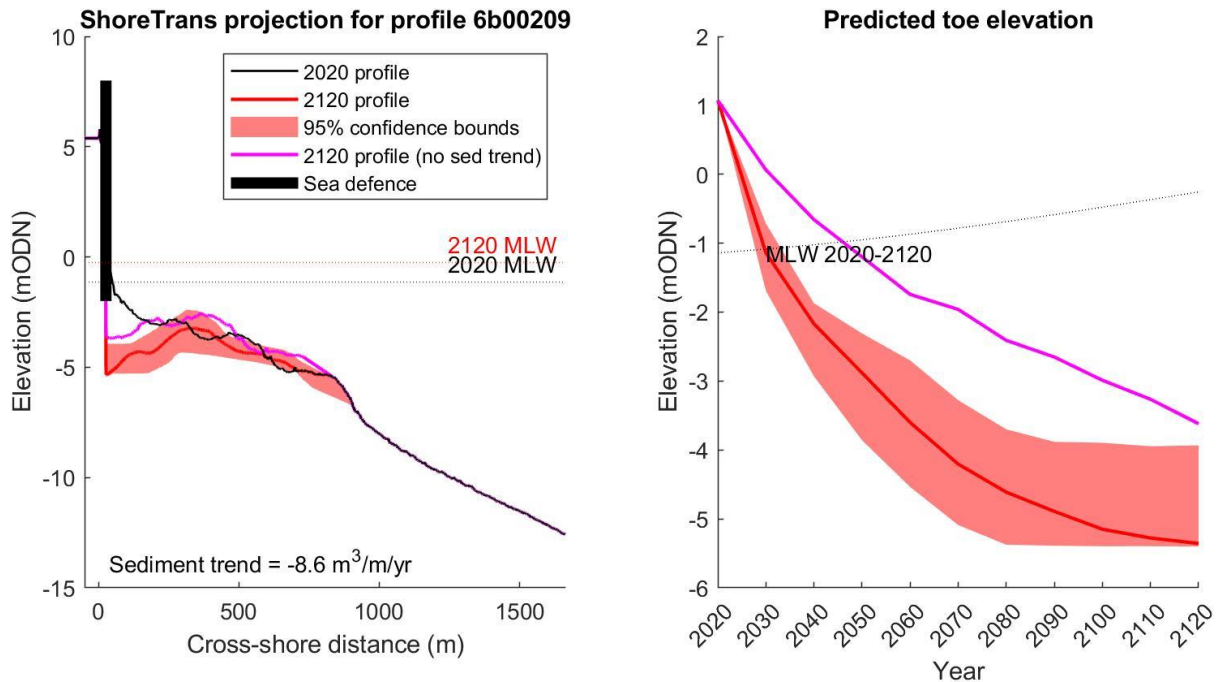

Figure D-15. ShoreTrans results for profile 6b00209 on Teignmouth’s Seafront Beach. Left: predicted cross-sectional profile evolution between 2020 and 2120. Right: predicted beach elevation at the toe of the seawall over time. Results are shown with (red) and without (magenta) inclusion of existing sediment supply trends. Mean Low Water (MLW) elevation is shown for reference. The sea defence cross-shore position is indicated, but toe depth is unknown.

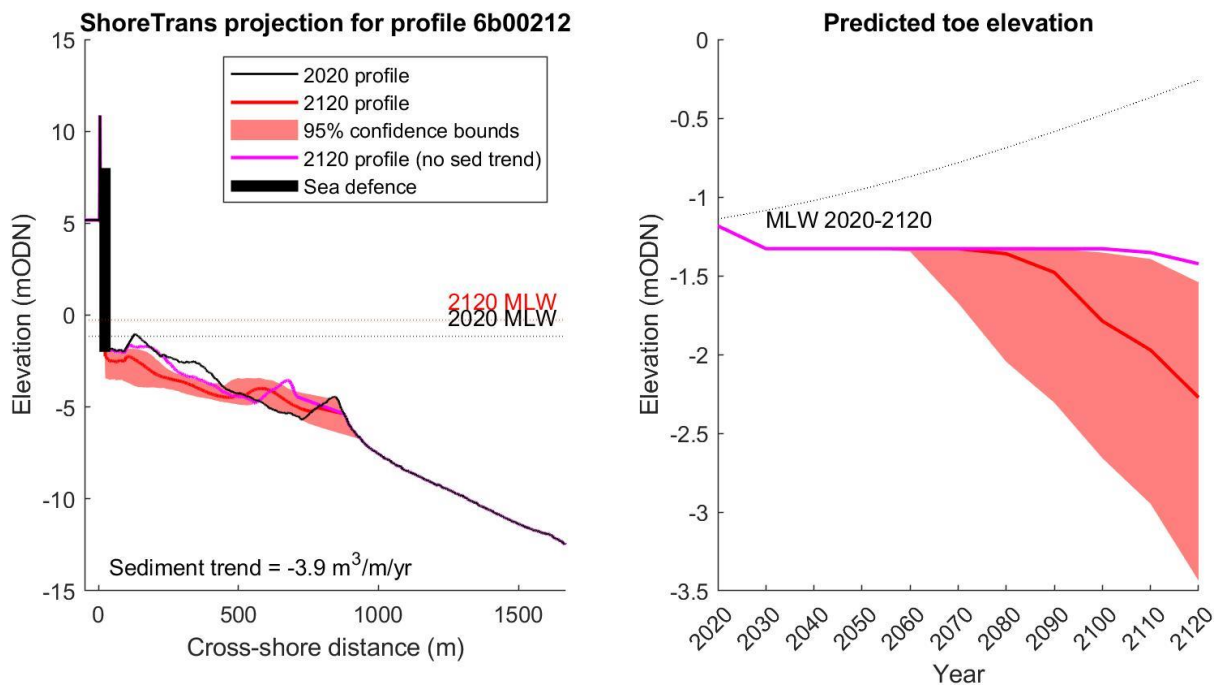

Figure D-16. ShoreTrans results for profile 6b00212 on Teignmouth’s Seafront Beach. Left: predicted cross-sectional profile evolution between 2020 and 2120. Right: predicted beach elevation at the toe of the seawall over time. Results

are shown with (red) and without (magenta) inclusion of existing sediment supply trends. Mean Low Water (MLW) elevation is shown for reference. The sea defence cross-shore position is indicated, but toe depth is unknown.

D.3.2 Point car park to Teignmouth Spit

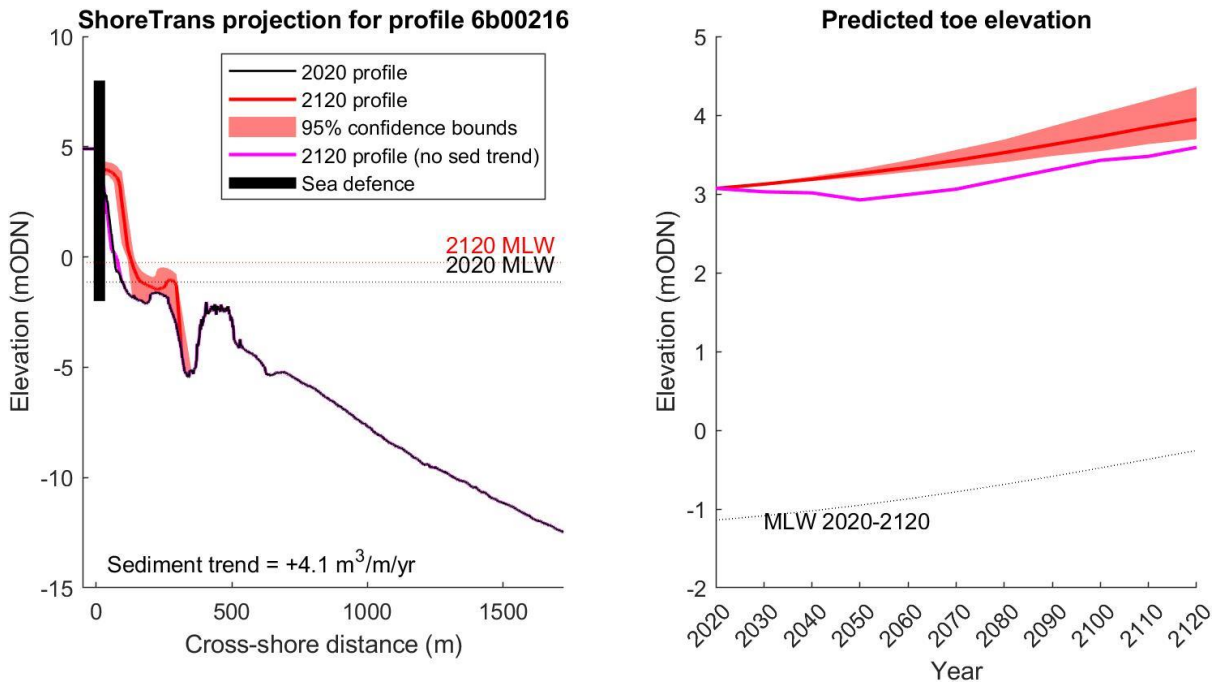

Figure D-17. ShoreTrans results for profile 6b00216 on Teignmouth’s Seafront Beach. Left: predicted cross-sectional profile evolution between 2020 and 2120. Right: predicted beach elevation at the toe of the seawall over time. Results are shown with (red) and without (magenta) inclusion of existing sediment supply trends. Mean Low Water (MLW) elevation is shown for reference. The sea defence cross-shore position is indicated, but toe depth is unknown.

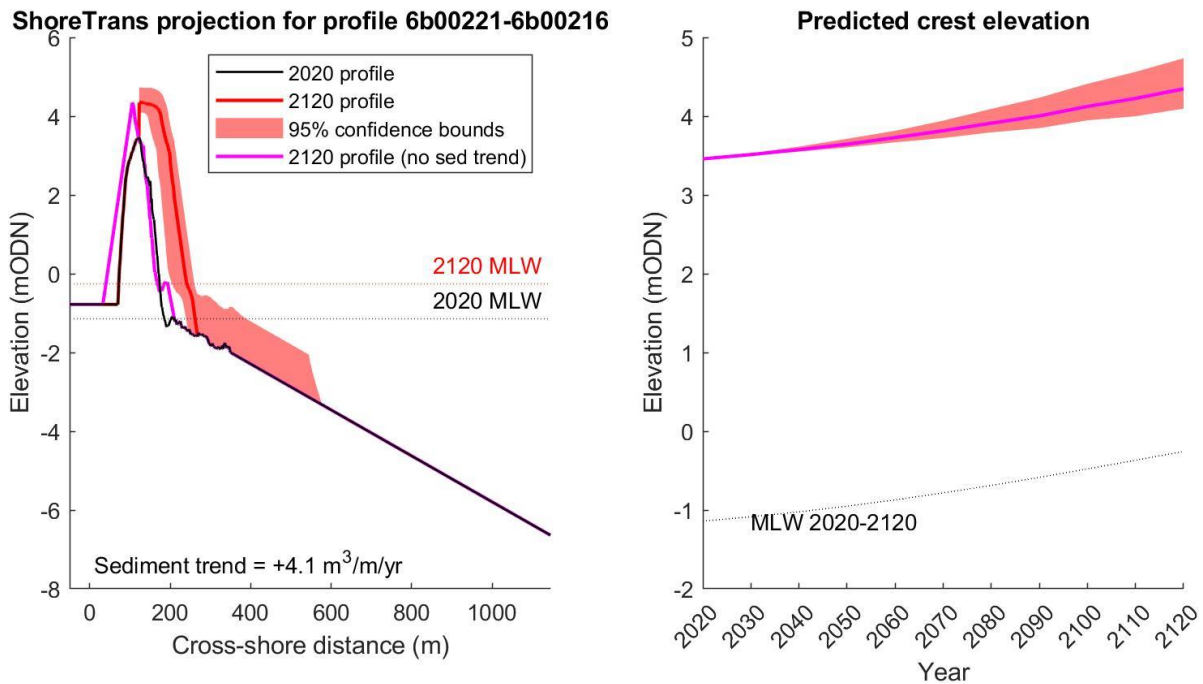

Figure D-18. ShoreTrans results for Teignmouth Sand Spit (approximately between profiles 6b00221-6b00216). Left: predicted cross-sectional profile evolution between 2020 and 2120. Right: predicted beach elevation at the barrier

crest over time. Results are shown with (red) and without (magenta) inclusion of existing sediment supply trends. Mean Low Water (MLW) elevation is shown for reference.

D.3.3 Teignmouth Back Beach

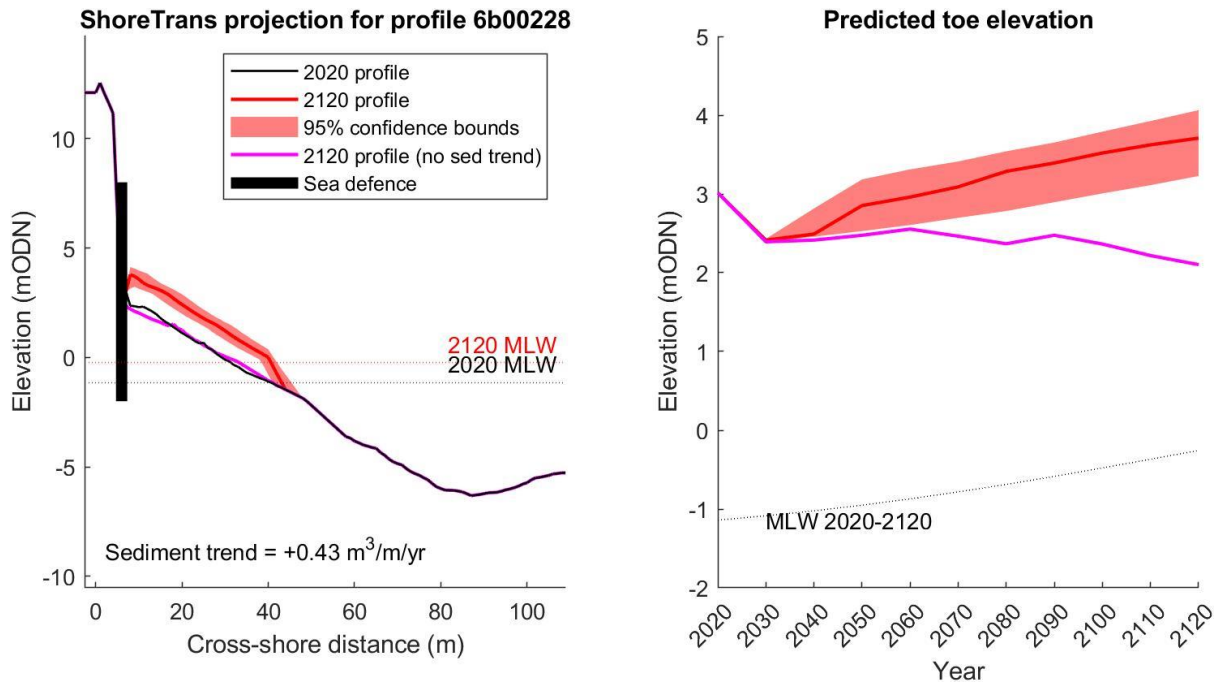

Figure D-19. ShoreTrans results for profile 6b00228 on Teignmouth’s Back Beach. Left: predicted cross-sectional profile evolution between 2020 and 2120. Right: predicted beach elevation at the toe of the seawall over time. Results are shown with (red) and without (magenta) inclusion of existing sediment supply trends. Mean Low Water (MLW) elevation is shown for reference. The sea defence cross-shore position is indicated, but toe depth is unknown.

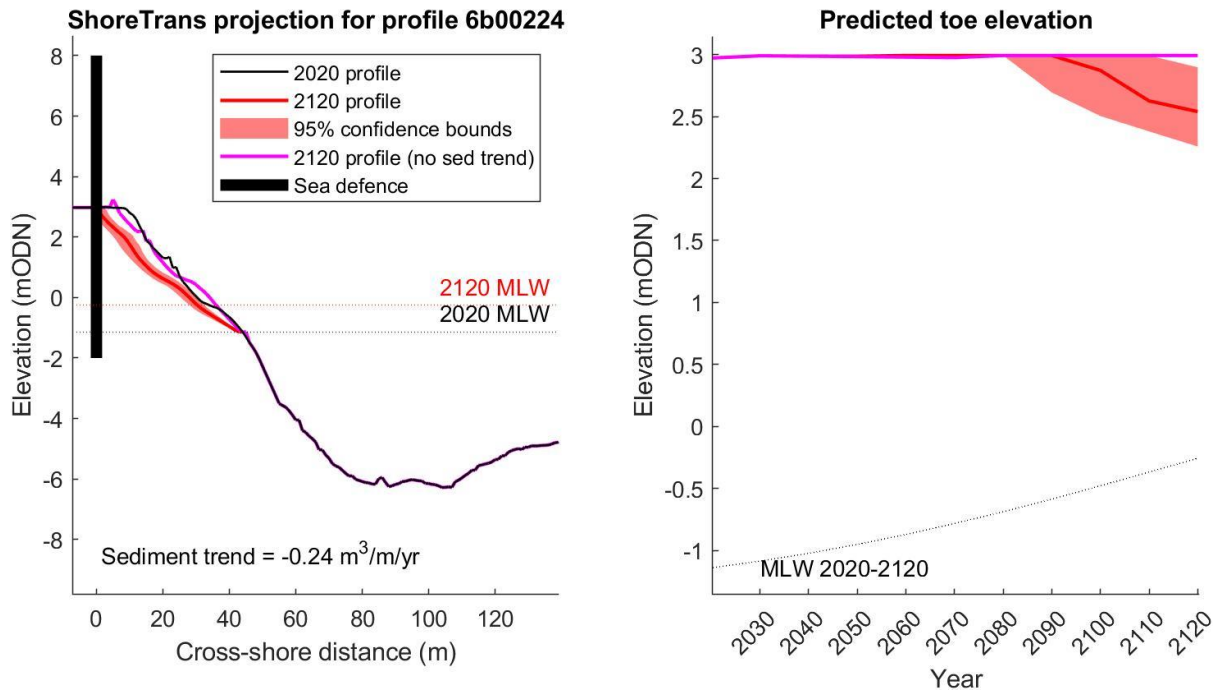

Figure D-20. ShoreTrans results for profile 6b00224 on Teignmouth’s Back Beach. Left: predicted cross-sectional profile evolution between 2020 and 2120. Right: predicted beach elevation at the toe of the seawall over time. Results

are shown with (red) and without (magenta) inclusion of existing sediment supply trends. Mean Low Water (MLW) elevation is shown for reference. The sea defence cross-shore position is indicated, but toe depth is unknown.

D.3.4 Shaldon Beach

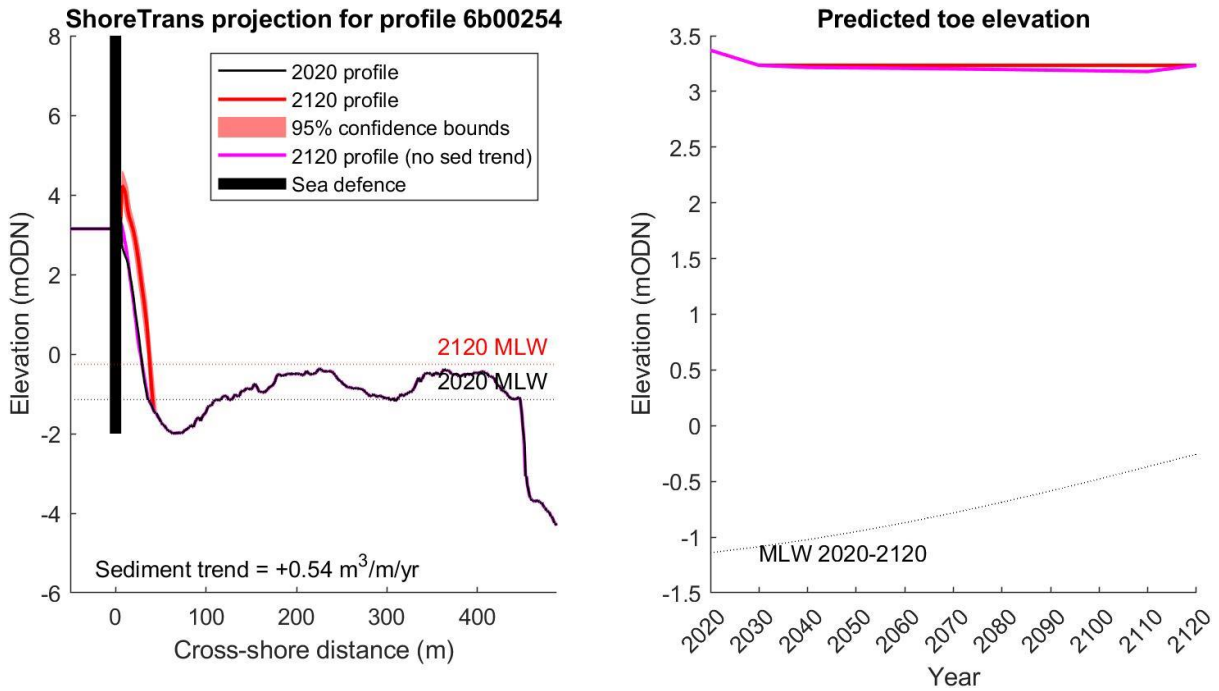

Figure D-21. ShoreTrans results for profile 6b00254 on Shaldon Beach. Left: predicted cross-sectional profile evolution between 2020 and 2120. Right: predicted beach elevation at the toe of the seawall over time. Results are shown with (red) and without (magenta) inclusion of existing sediment supply trends. Mean Low Water (MLW) elevation is shown for reference. The sea defence cross-shore position is indicated, but toe depth is unknown.

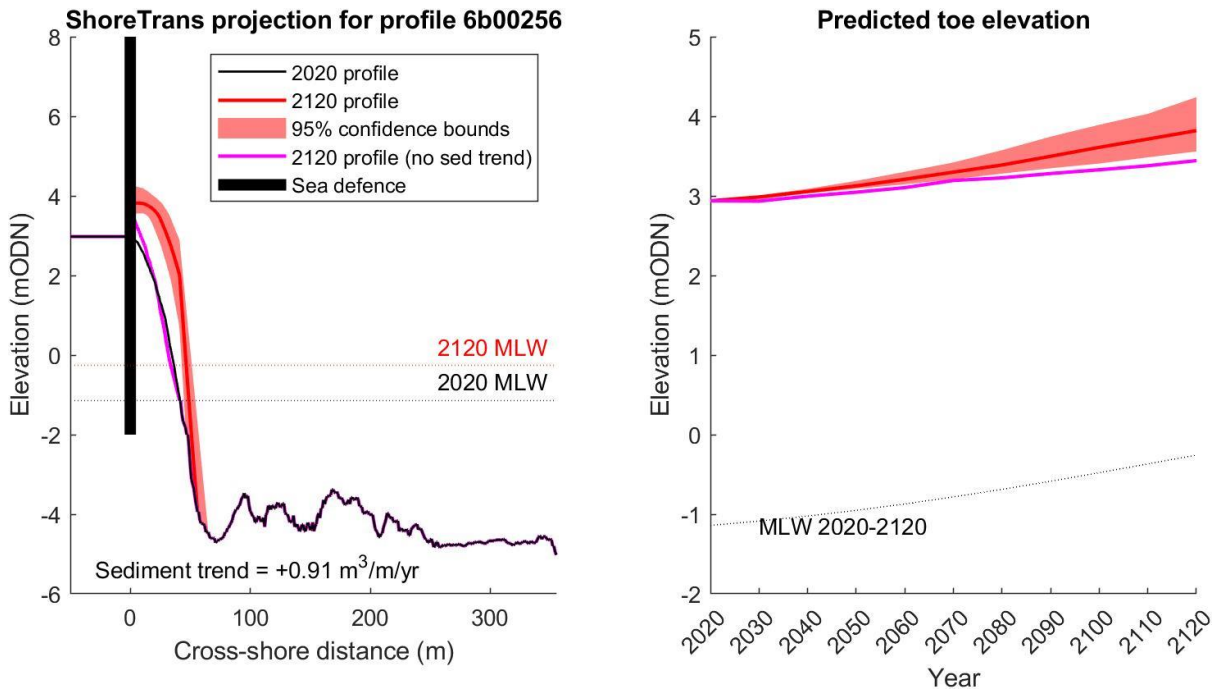

Figure D-22. ShoreTrans results for profile 6b00256 on Shaldon Beach. Left: predicted cross-sectional profile evolution between 2020 and 2120. Right: predicted beach elevation at the toe of the seawall over time. Results are shown with (red) and without (magenta) inclusion of existing sediment supply trends. Mean Low Water (MLW) elevation is shown for reference. The sea defence cross-shore position is indicated, but toe depth is unknown.

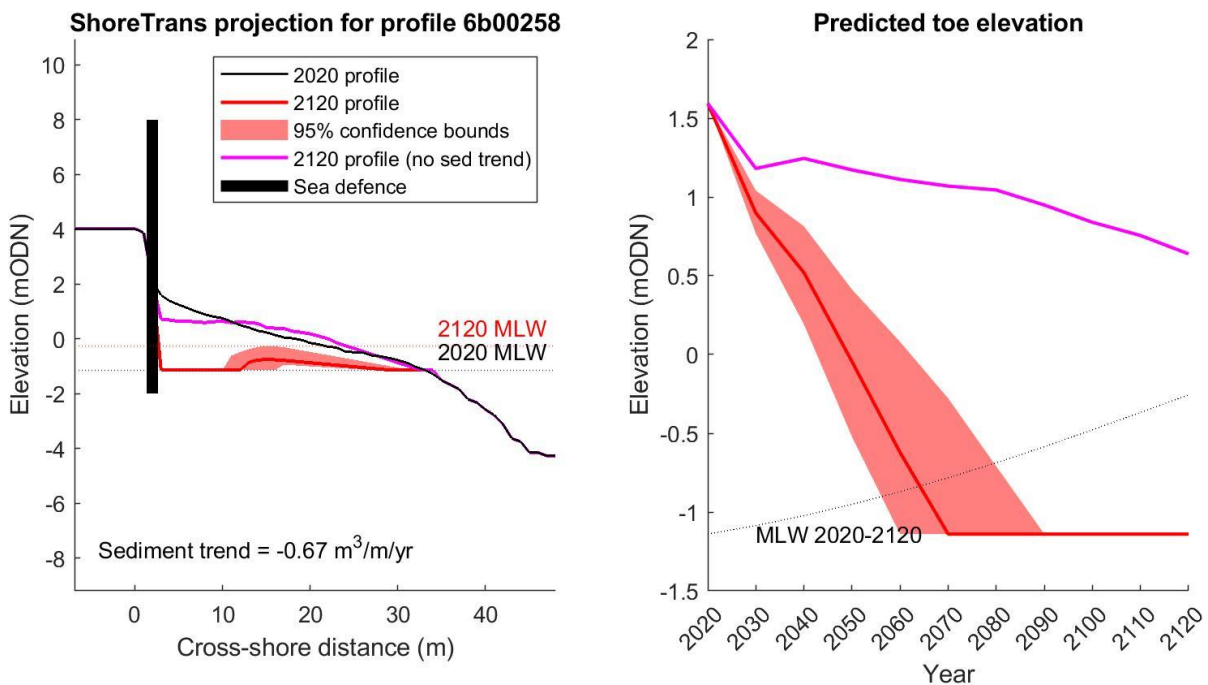

Figure D-23. ShoreTrans results for profile 6b00258 on Shaldon Beach. Left: predicted cross-sectional profile evolution between 2020 and 2120. Right: predicted beach elevation at the toe of the seawall over time. Results are shown with (red) and without (magenta) inclusion of existing sediment supply trends. Mean Low Water (MLW) elevation is shown for reference. The sea defence cross-shore position is indicated, but toe depth is unknown.

Appendix E Teignmouth Point Breakwater Modelling

Coastal Marine Applied Research (CMAR), as part of WP5, has undertaken XBeach modelling to assess the role of the point breakwater which extends across Denn Spit. As a prominent coastal defence feature, there is a desire to gain a better understanding of the role of the wall and its impact on Denn Spit under different scenarios.

XBeach can simulate the propagation of incident and infragravity waves, wave-induced currents, sediment transport, and morphological changes, solving the time-dependent short-wave action-balance equations, roller energy equations, the non-linear shallow water equations of mass and momentum, sediment transport formulations, and bed updating. Wave dissipation is modelled, and a roller model is used to represent the momentum carried after wave breaking. Radiation stress gradients then drive infragravity motion and unsteady currents in the model, which are solved with the non-linear shallow water equations.

E.1 Model domain

The model domain was developed from the previous BMP Delft 3D modelling. For this modelling, bathymetric and topographic data from several sources were merged to obtain a complete digital elevation model of the seabed and dry land areas (Figure E-1). The exception was the LiDAR data, which was updated to 2023 LiDAR to better match the beach levels in 2023 for the calibration process. In addition, the 2023 beach levels were significantly lower than in 2020 and considered to be a more conservative approach for the storm scenarios to have initial bed levels of a more depleted beach.

The model domains were developed using the following data:

- Multibeam bathymetry data collected in 2020 for the SWCMP with a horizontal resolution of 0.5 m.
- Multibeam bathymetry data collected in 2018 for Network Rails' South West Rail Resilience Programme (SWRRP) with a horizontal resolution of 0.01 m.
- EMODnet single beam bathymetry data with ~115 m horizontal resolution (<https://emodnet.ec.europa.eu/en/bathymetry>).
- Topography data was obtained from SWCM LiDAR surveys on the 23rd of March 2023, with a spatial resolution of 1m.

The 2D domain required alignment with the grid's x-axis perpendicular to the shoreline, necessitating a map rotation of 150° as shown in Figure E-1. This rotation means that the eastern edge of the model domain represents the shoreline, while the western portion represents the offshore region. The 2D domain was developed with a total alongshore length of 4.5 km.

Since the wave conditions being modelled are bi-directional, from the south (~155-180°) and south-east (~100-120°), the model domain was configured to avoid wave shadow effects from these dominant wave directions. Denn Spit was strategically positioned within the alongshore domain to ensure that model boundary effects, particularly lateral boundary wave shadows, would not influence the region of primary interest.

Model resolution varies from 5 m in the area of interest to 20 m offshore and alongshore from the area of interest.

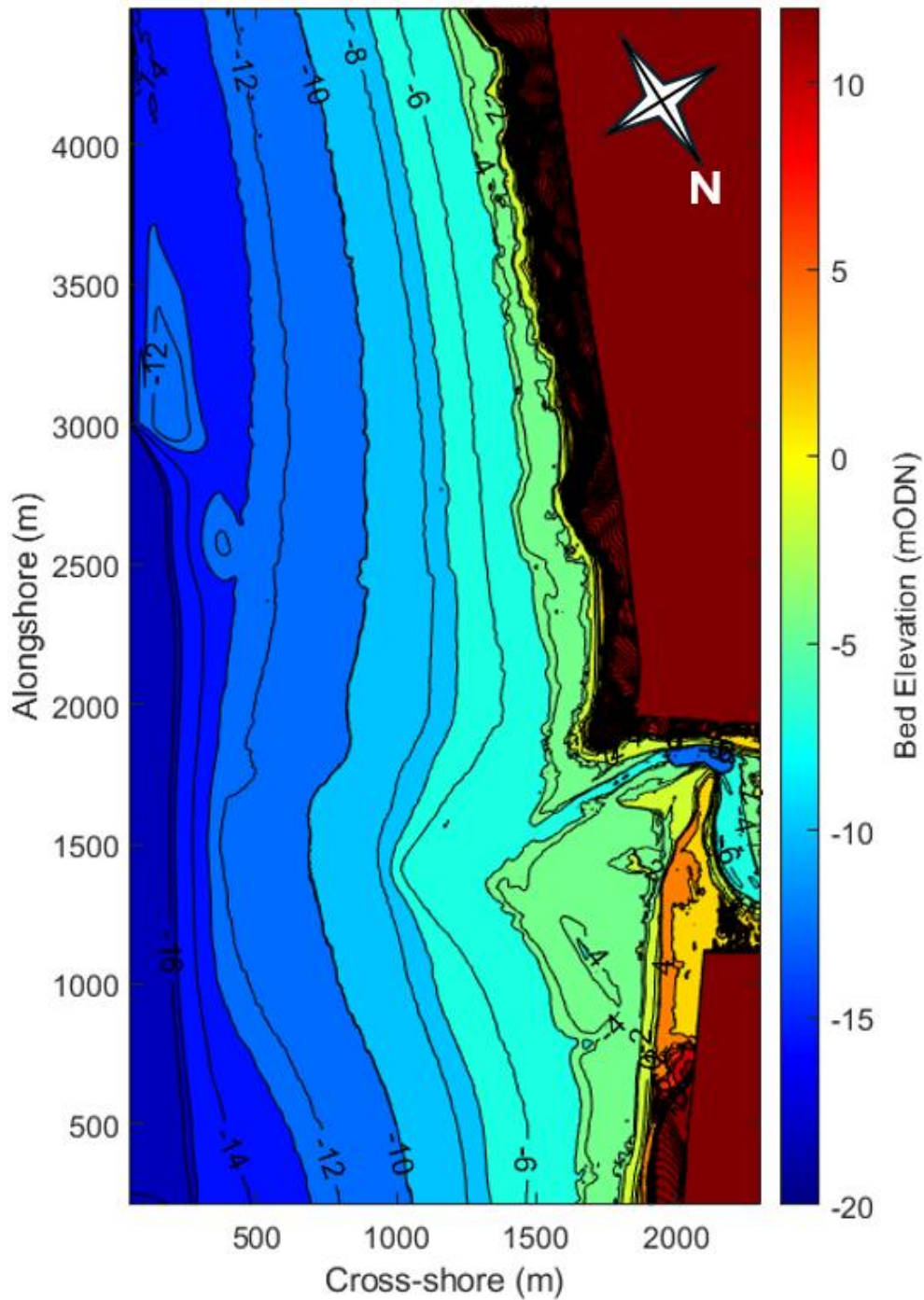

Figure E-1. Bathymetry of the Teignmouth model domain, with bed elevation (m OD) represented by the colour scale. Note that the domain is rotated 150°, as indicated by the north arrow, which is required for XBeach. The shoreline is visible along the eastern edge with deeper water (dark blue) in the offshore region. Denn Spit is visible around the 1500-2000m alongshore position where the shoreline curves inward.

E.1.1 Non-erodible layer

Within XBeach, a non-erodible layer can be implemented which represents a hard substrate that limits erosion depth. This allows an area to be defined where erosion cannot occur beyond a specified elevation, simulating physical barriers like sea defences, bedrock, and cliffs. This is required for this assessment as it is key to representing the point breakwater. Figure E-2 shows the non-erodible layer where erodible beach areas have been assigned 10 m depth of sediment and areas of hard structure are assigned 0 m depth.

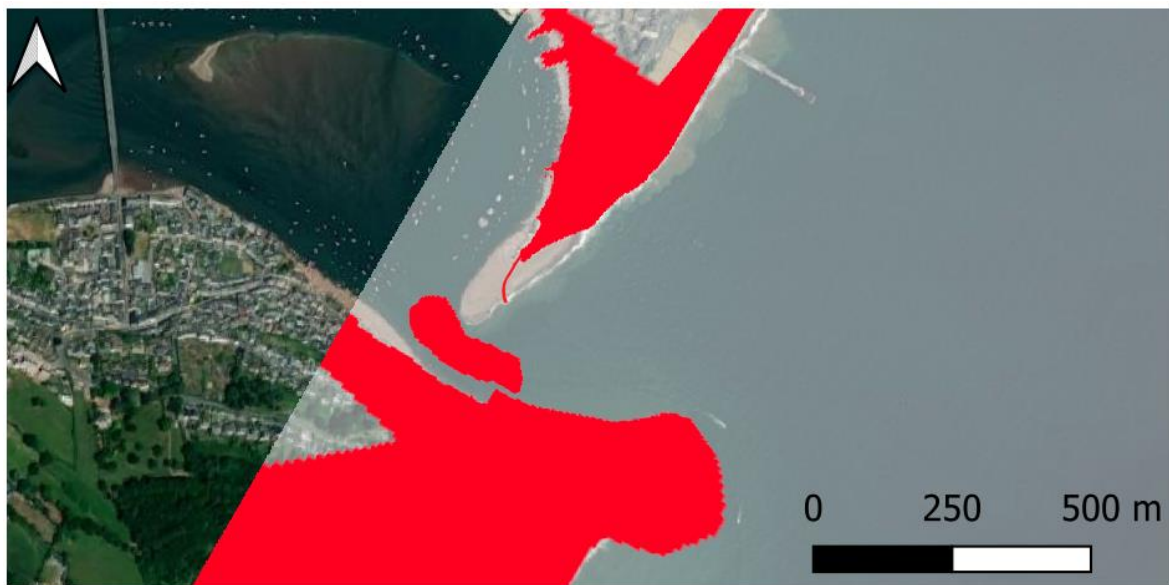

Figure E-2. Location of non-erodible layer at the location of Denn Spitt shown in red. The opacity shows the model extent landwards. Note the non-erodible area within the channel used to define bedrock extent.

E.2 Sediment Size

Sediment size for D50 of 3 mm and D90 of 4.5 mm was used in line with values used in the BMP.

E.3 Calibration and Validation Data Limitations

The calibration and validation of the XBeach model for Teignmouth Point presented significant challenges due to limited available data. The only suitable calibration/validation data was collected during October-November 2023, with profile data available on three dates: 3rd October 2023, 30th October 2023, and 14th November 2023.

Figure E-3 illustrates the hydrodynamic conditions during this calibration period, showing water levels, significant wave height (H_s), wave direction, and wave period (T_p) from October 1st to November 14th, 2023. These data reveal several notable wave events between the survey dates. The period between October 15-18 experienced a significant wave event with H_s exceeding 2.5m, accompanied by a marked shift in wave direction from approximately 170° (south-southeast) to around 120° (southeast). Another

substantial wave event occurred around November 2-3 (Storm Ciarán), with H_s approaching 3 m while wave directions remained predominantly between 160-180° (south to south-southeast).

Figure E-5 shows the two beach profiles closest to the study area (Reg ID: 6b00219 and 6b00216, location in Figure E-4). A notable observation from these profiles is the contrasting beach response between the two locations during the same time period. Profile 6b00219 exhibits clear erosion between 3rd and 30th October 2023, with the beach level lowering significantly, particularly between chainage 60m and 100m. Conversely, profile 6b00216 shows accretion during this same period, suggesting complex sediment transport patterns and potentially indicating a redistribution of material along the shoreline.

The absence of comprehensive pre- and post-storm survey data limited our ability to calibrate the model against observed storm-induced morphological change. Additionally, the profiles do not fully capture the complex three-dimensional morphology of Denn Spit and the point breakwater area.

Calibration was attempted by running a "Storm Ciarán" simulation (see Section E.4) to recreate the change observed at profile 6b00216 between 30th October and 14th November 2023. However, this approach presented multiple challenges. First, the observed morphological changes were relatively small. Second, the starting digital elevation model (DEM) was based on LiDAR data collected in March 2023, several months before the calibration period, potentially introducing baseline discrepancies. Third, computational constraints necessitated using shortened forcing conditions, which may have affected the model's ability to fully capture the storm dynamics.

Given these compounding challenges, a decision was made to run the Storm Scenarios with the default XBeach parameters. While this approach introduces some uncertainty in the absolute quantification of morphological change and exact location, it still provides valuable insights into the relative differences between scenarios (with and without the point breakwater), which is the primary focus of this study.

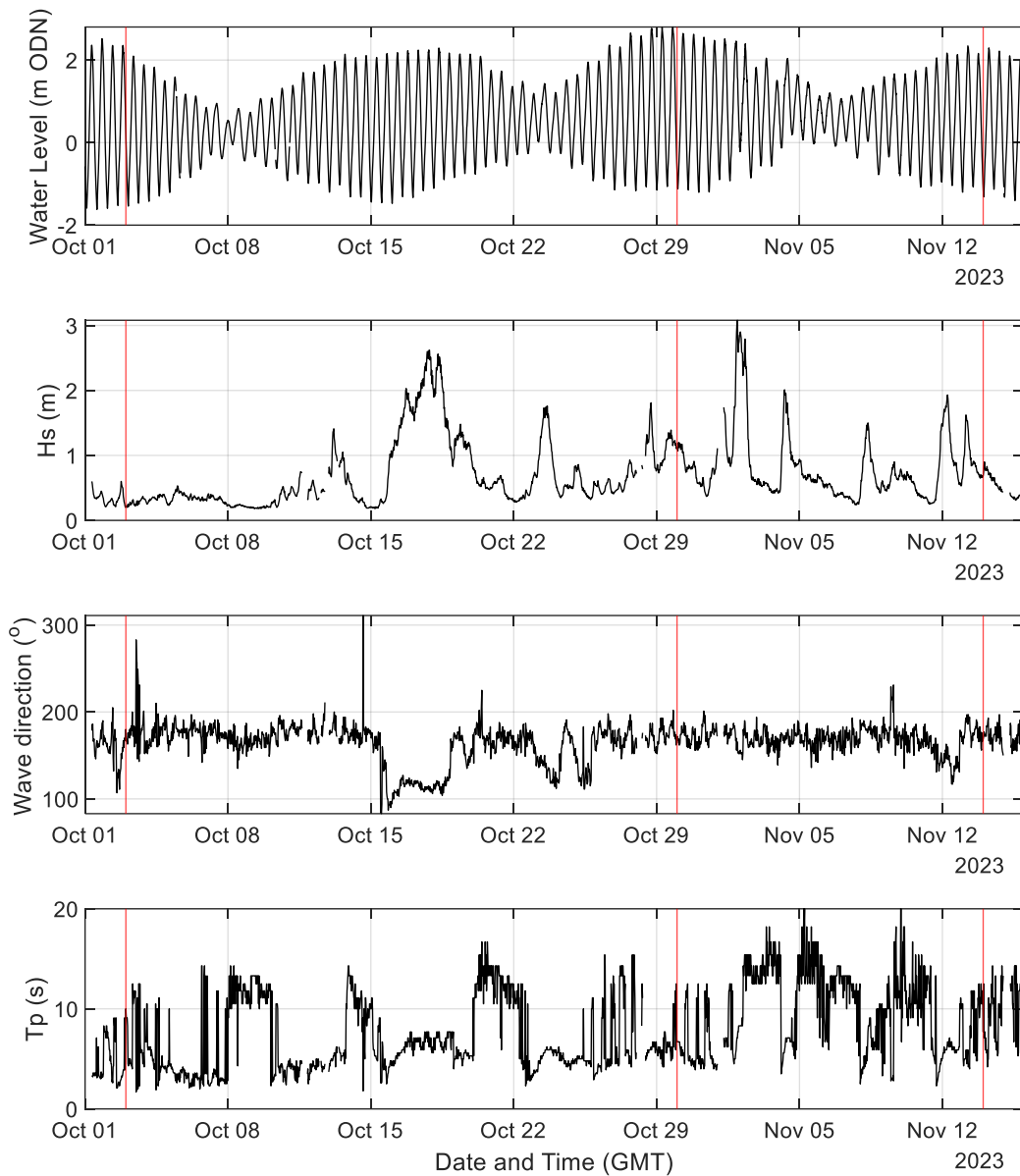

Figure E-3. Hydrodynamic conditions at Teignmouth from October 1st to November 14th, 2023, covering the period between beach profile surveys. From top to bottom: water level (m), significant wave height H_s (m), wave direction (degrees), and peak wave period T_p (s). Red vertical lines indicate the dates of profile measurements (October 3rd, October 30th, and November 14th, 2023).



Figure E-4. Aerial view of Denn Spit showing the locations of beach profile measurements. The red line on the left corresponds to Profile Reg ID: 6b00219 (shown in the top panel of Figure E-5), while the red line on the right corresponds to Profile Reg ID: 6b00216 (shown in the middle and bottom panels of Figure E-5).

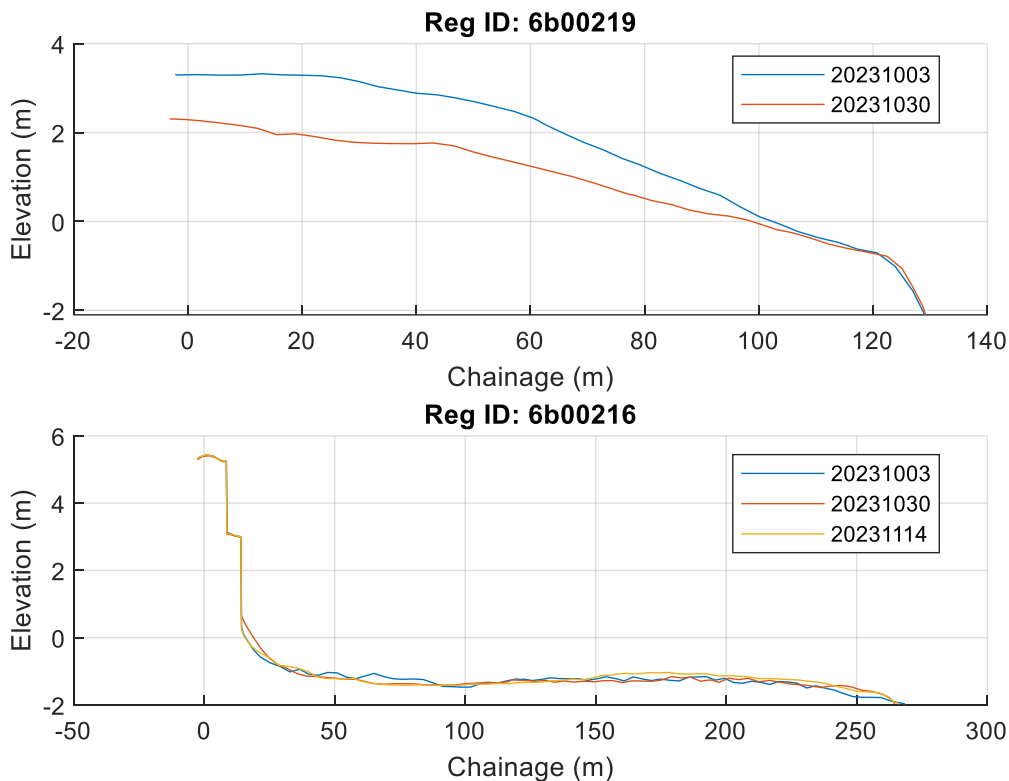

Figure E-5. Beach profile measurements at Teignmouth Point during the calibration period: Profile Reg ID: 6b00219 (top) showing erosion between October 3rd and October 30th 2023, and Profile Reg ID: 6b00216 (bottom).

E.4 Forcing Conditions

Storm Scenarios

Four scenarios covering storms from the south and east with and without the point breakwater in place have been undertaken. These mirror the storms that have been already adopted in the current BMP (Table E-1).

Storm threshold waves from the south, with mean spring tide:

- Scenario 1 – Denn Spit/The Point in place with the point breakwater
- Scenario 2 – Denn Spit/The Point in place without the point breakwater

Storm threshold waves from the east, with mean spring tide:

- Scenario 3 – Denn Spit/The Point in place with the point breakwater
- Scenario 4 – Denn Spit/The Point in place without the point breakwater

Tidal elevations used were also those adopted in the current BMP as a mean spring tide (Figure E-6). For more information on how these forcing conditions have been derived refer to the BMP documents.

Table E-1. Summary of storm-threshold wave conditions from the south and east, each with a probability of occurrence of four times per year (1-in-0.25 years). Nodes 1 to 4 represent model forcing nodes spaced evenly along the seaward boundary of the large-scale wave grid, arranged from south to north. In this study Node 3 was used across the boundary (highlighted in orange).

Scenario	Node 1			Node 2			Node 3			Node 4		
	<i>Hs</i> (m)	<i>Tp</i> (s)	<i>Dm</i> (°)	<i>Hs</i> (m)	<i>Tp</i> (s)	<i>Dm</i> (°)	<i>Hs</i> (m)	<i>Tp</i> (s)	<i>Dm</i> (°)	<i>Hs</i> (m)	<i>Tp</i> (s)	<i>Dm</i> (°)
1-in-0.25 yr RP wave S	1.6	7.8	156	2.7	8.1	166	2.7	8.4	170	2.8	9.3	178
1-in-0.25 yr RP wave E	2.0	7.7	105	2.2	7.5	114	2.1	7.5	116	1.9	7.5	117

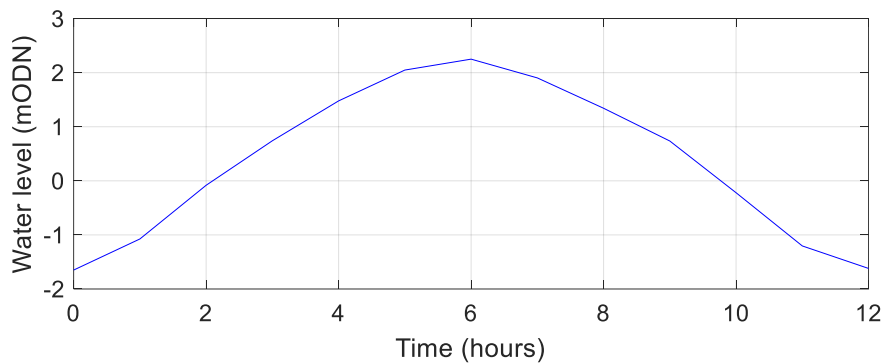

Figure E-6. Mean spring tide used in the Southerly and Easterly Storm Runs.

Storm Ciarán

Storm Ciarán was a severe extratropical cyclone that impacted the South Coast of the UK from November 1st to November 2nd, 2023, bringing strong winds and significant wave activity to the region (Met Office, 2023). At the Dawlish wave buoy during this period, maximum significant wave heights of 3.08 m were recorded, with peak wave periods ranging from 10-15 seconds. These wave conditions coincided with high pressures and surge, resulting in maximum water elevations of 2.46 mODN recorded at the Exmouth tide gauge. The storm was characterized by southerly wave directions (approximately 170-180°).

The green vertical lines in Figure E-7 indicate the start and end times of the XBeach model simulation for this storm event. This simulation provided an opportunity to evaluate model performance during a recent storm event that occurred within our calibration period, allowing for validation against the profile measurements taken before and after the storm. However, there were limitations in the data available for calibration/validation which meant this process was unsuccessful (see Section A.4)

Note the model run conditions are interpolated to a 1 hr timestep for computational efficiency and therefore coarser than conditions presented in Figure E-7.

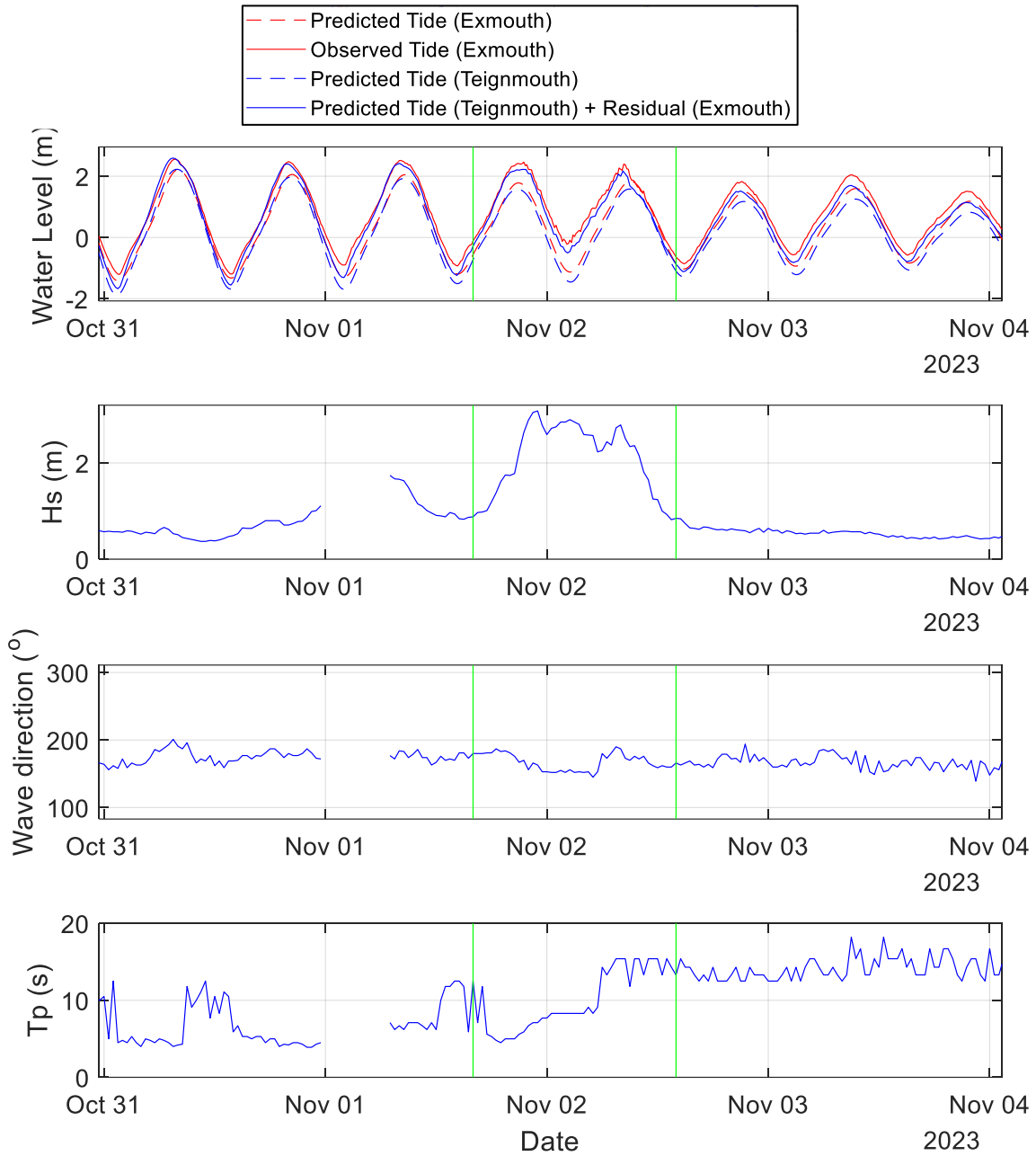

Figure E-7. Hydrodynamic conditions during Storm Ciarán. From top to bottom: water levels (m ODN) at Exmouth and Teignmouth (observed, predicted, and predicted with residual), significant wave height H_s (m), wave direction (degrees), and peak wave period T_p (s). Vertical green lines indicate the start and end of the XBeach model simulation period. Data from Dawlish wave buoy and Exmouth tide gauge (<https://coastalmonitoring.org/cco/https://southwest.coastalmonitoring.org/>).

Extreme Event Scenario

In addition to the storm scenarios and Storm Ciarán event described above, an extreme event scenario was developed to assess the performance of Denn Spit and the point breakwater under more severe conditions.

The extreme event was defined using a combination of:

- 1-in-100-year return period extreme water level of 3.27 mODN from the Coastal Flood Boundary Dataset
- 1-in-100-year return period extreme easterly wave height of 4.44m from the Dawlish waverider buoy at -14 mODN depth contour

The Dawlish waverider buoy data (Table 2-2) provided directional extreme wave statistics based on measurements between December 2010 and February 2024. For easterly waves (35°–145°), the 1-in-100-year significant wave height was determined to be 4.44m.

It should be noted that combining a 1-in-100 year water level with a 1-in-100 year wave height does not result in a 1-in-100 year joint probability event. The joint return period of this combination is likely significantly higher, however, due to data limitations and the absence of joint probability information at the specific model boundary location, this approach was adopted to provide a conservative basis for the extreme event assessment.

For this extreme scenario, a wave direction of 112° was selected as representative of easterly storm conditions that would generate the most significant impacts on Denn Spit and the point breakwater. The peak wave period (T_p) was set at 7.5 seconds, consistent with the observed relationship between wave height and period in the Dawlish waverider buoy dataset for easterly storms.

Two model runs were conducted for this extreme event scenario:

- Scenario 5 – Denn Spit/The Point in place with the point breakwater
- Scenario 6 – Denn Spit/The Point in place without the point breakwater

This extreme event assessment complements the previously described storm threshold scenarios by providing insights into the performance and potential vulnerability of Denn Spit and the point breakwater under more severe, lower-frequency conditions.

E.5 Results and Discussion

The results of the XBeach modelling simulations for the four scenarios (Southerly and Easterly storms, each with and without the point breakwater) and Storm Ciarán are presented in Figure E-8. This figure shows the predicted elevation changes for each scenario and the differential impact of the point breakwater.

Easterly Storm Scenario

Under easterly storm conditions (Figure E-8, top row), the presence of the point breakwater influences the morphological response of Denn Spit. With the point breakwater in place (left panel), modest erosion (yellow to light orange, -0.2 to -0.5m) is predicted along the seaward face of Denn Spit, with more substantial erosion (orange to red, -0.5 to -2.0m) concentrated near the northeastern end of the spit. In contrast, without the point breakwater (middle panel), the erosion pattern intensifies with greater erosion depths extending across a larger area of the spit – in the area of the point breakwater.

Along the western part of the spit the erosion caused by the storm is similar with and without the point breakwater.

The difference plot (right panel) highlights these effects clearly, with predominantly negative values (red to orange) along the central and northeastern sections of Denn Spit, indicating that erosion is extended to the location of the point breakwater. This suggests that this area would be most vulnerable to easterly storms if the point breakwater were absent.

Southerly Storm Scenario

For southerly storm conditions (Figure E-8, middle row), the morphological response differs somewhat from the easterly scenario. With the point breakwater in place (left panel), erosion is primarily concentrated along the southern flank of Denn Spit, with moderate erosion depths (yellow to orange, -0.2 to -1.0m). Without the point breakwater (middle panel), the erosion pattern extends further landward and along the spit, with increased erosion depths in some areas.

The difference plot (right panel) reveals a more complex pattern than for the easterly scenario. While negative values (red to orange) indicate greater erosion without the point breakwater in several areas, particularly along the southern edge of the spit, there are also some positive values (green) indicating localized areas where either accretion might be greater without the wall or erosion is less deep.

Storm Ciarán Scenario

The Storm Ciarán simulation (Figure E-8, bottom row) shows patterns of morphological change similar to the southerly storm scenario, which is consistent with the recorded wave direction during this event (predominantly 170-180°).

With the point breakwater in place (left panel), erosion is concentrated along the southern face of Denn Spit, with moderate erosion depths. When the point breakwater is removed (middle panel), there is increased erosion depth and extent, particularly in the area where the point breakwater would be located. The difference plot (right panel) clearly demonstrates the protective function of the point breakwater during this real-world storm event. Negative values (orange to red) dominate the area around and behind where the wall would be, indicating substantially greater erosion in the absence of the wall. This real-world storm scenario provides further evidence that the point breakwater serves as a coastal defence feature.

Extreme Storm Scenario

The results for the extreme storm scenario are presented in Figure E-9. With the breakwater in place, we see significant erosion (1.8 m) on the seaward side of the structure and even greater (2 m) loss behind the breakwater. Denn Spit itself has moved landward by ~10 m caused by rollback under overwash conditions. While the overall response shows widespread erosion on the seaward side, balanced by accretion on the landward side of the Denn Spit, the presence of the breakwater does support some accretion at the end of the structure. For the scenario where the breakwater is removed the results are comparable with a significant rollback of Denn Spit taking place with the landward shift almost double that with the breakwater in place (~20 m; Figure E-9). Significantly, the overall elevation of the spit is subsequently further lowered by ~0.9 m compared to the run with the breakwater in place.

Denn Spit Wave and Water Level Conditions

To support each of the model scenario runs that have been presented the wave heights either side of Denn Spit have been extracted and presented in Figure E-10. This figure presents the wave heights on the seaward and landward side of Denn Spit throughout the model simulation for each scenario with and without the breakwater in place. The results highlight the role that Denn Spit has in reducing wave conditions within the estuary with heights significantly reduced in all scenarios regardless of the presence of the breakwater (Figure E-10). This is further shown in the maximum wave height for each scenario either side of the Point with and without the breakwater (Table E-2).

Figure E-11 shows the water level either side of Denn Spit for each model scenario. There are minimal differences in water levels between the seaward and landward sides of Denn Spit, and no discernible difference between scenarios with or without the breakwater for all model scenarios. This is also shown in the maximum water level for each scenario either side of the Point with and without the breakwater (Table E-3).

Table E-2. Maximum modelled wave heights (H_{rms}) either side of the Point for the four difference scenarios each with and without the breakwater in place.

Scenario	Point 1		Point 2	
	<i>Without Breakwater</i>	<i>With Breakwater</i>	<i>Without Breakwater</i>	<i>With Breakwater</i>
Easterly Storm 1-in-0.25 yr RP	1.18	1.18	0.24	0.22
Southerly Storm 1-in-0.25 yr RP	1.02	1.02	0.14	0.13
Storm Ciaran	0.98	0.98	0.19	0.20
Easterly Storm 1-in-100 yr RP	1.77	1.77	0.83	0.80

Table E-3. Maximum water levels (mODN) either side of the Point for the four difference scenarios each with and without the breakwater in place.

Scenario	Point 1		Point 2	
	<i>Without Breakwater</i>	<i>With Breakwater</i>	<i>Without Breakwater</i>	<i>With Breakwater</i>
Easterly Storm 1-in-0.25 yr RP	2.03	2.01	2.07	2.07
Southerly Storm 1-in-0.25 yr RP	2.06	2.06	2.05	2.06
Storm Ciaran	2.19	2.19	2.20	2.20
Easterly Storm 1-in-100 yr RP	3.15	3.15	3.19	3.19

Overall Findings

Across all scenarios, the following points summarise the results:

- The point breakwater provides protection against erosion, at the location of the wall, particularly during easterly storm conditions.
- The effect of the point breakwater varies spatially and is dependent on storm direction, with easterly storms showing more uniform protection across the spit, while southerly storms exhibit more complex patterns of differential erosion and accretion.
- Under an extreme event significant rollback of the point is observed, although this is limited with the breakwater in place.

It is important to emphasise that these results are based on short-duration storm impact runs, which present several important limitations:

- Sustained high-energy winter conditions or consecutive storms would likely amplify the erosion extent and depth significantly beyond what is shown in these single-event simulations.
- The cumulative effect of multiple storm events would introduce complex morphological feedback mechanisms not captured in these isolated simulations.

- These simulations do not account for the potential impacts of sea level rise, which would further exacerbate erosion patterns.
- For scenarios with the breakwater in place, the model does not consider potential structural integrity issues that could arise when the front of the structure is subjected to erosion during storms.

These limitations suggest that while the point breakwater demonstrates protective benefits in these simulations, the real-world effectiveness under prolonged or more severe conditions may differ from these findings.

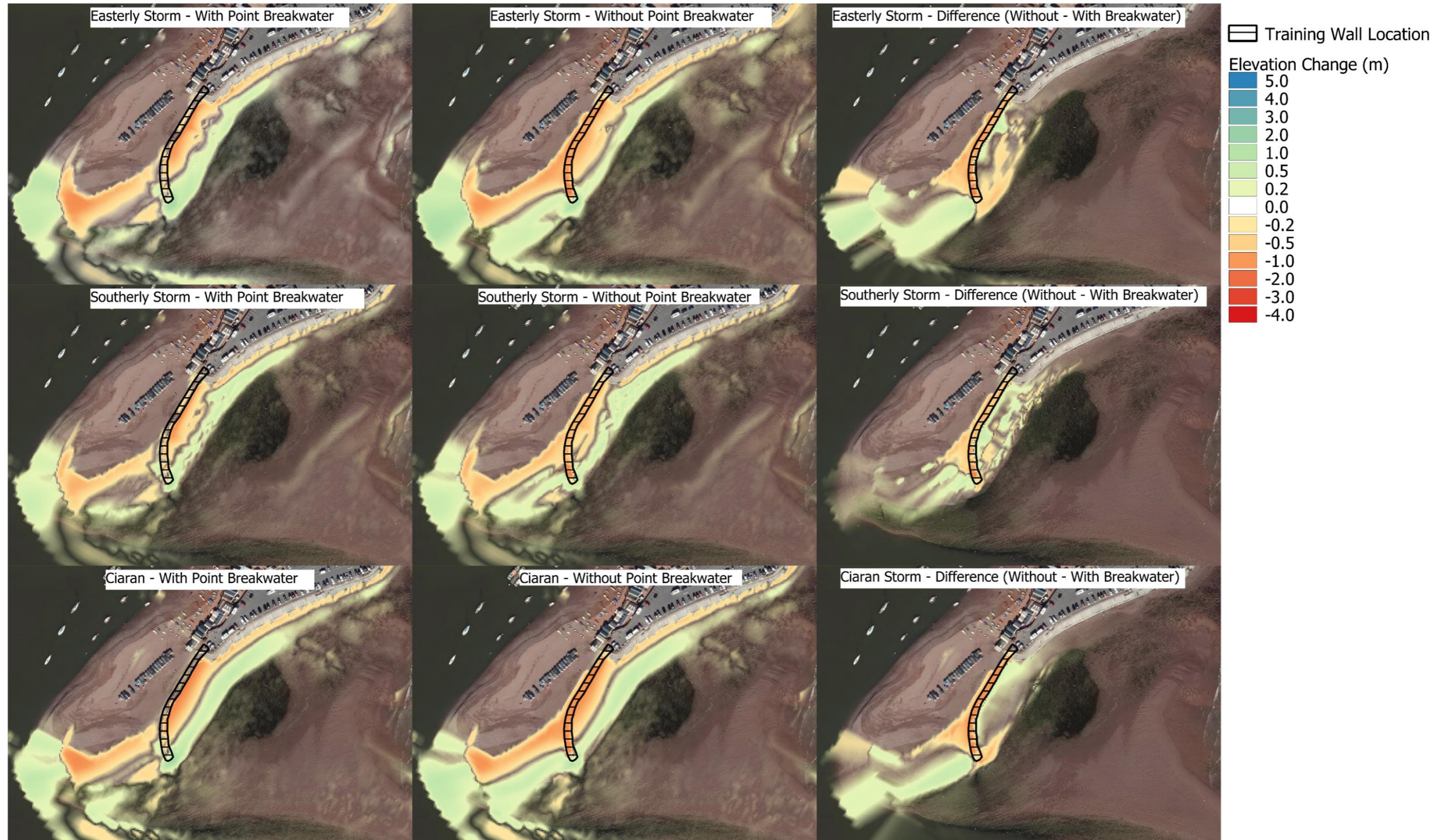

Figure E-8. Modelled elevation changes at Teignmouth Point under different storm scenarios and point breakwater configurations. Left column: elevation change with point breakwater in place; middle column: elevation change without point breakwater; right column: difference in elevation change between scenarios (Without Wall - With Wall). Top row: Easterly Storm; middle row: Southerly Storm; bottom row: Storm Ciarán. Negative values (red) in the difference plots indicate areas where erosion was greater (or accretion was less) without the point breakwater. Positive values (blue/green) indicate areas where accretion was greater (or erosion was less) without the point breakwater. The extended point breakwater location is marked in black.

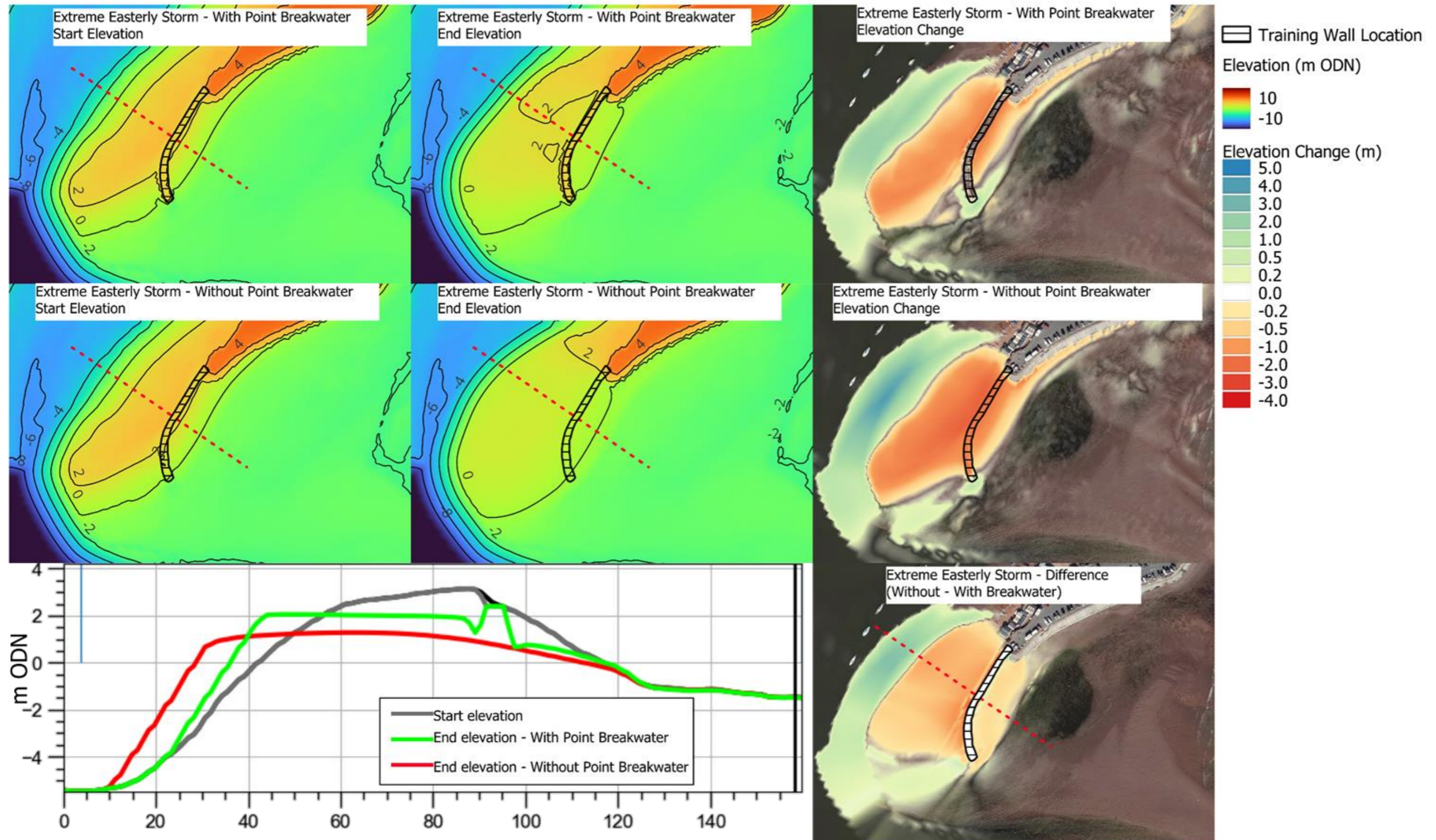

Figure E-9. Modelled start and end elevation and elevation changes at Teignmouth Point under an extreme easterly storm scenarios under different point breakwater configurations. Left column: start elevation; middle column: end elevation; right column: difference in elevation change between the start and end. Top row: with point breakwater; middle row: without point breakwater; bottom row: elevation across a profile (location in red dotted line in the maps) and the difference between with and without point breakwater runs. Negative values (red) in the difference plots indicate areas where erosion was greater (or accretion was less) without the point breakwater. Positive values (blue/green) indicate areas where accretion was greater (or erosion was less) without the point breakwater. The extended point breakwater location is marked in black.

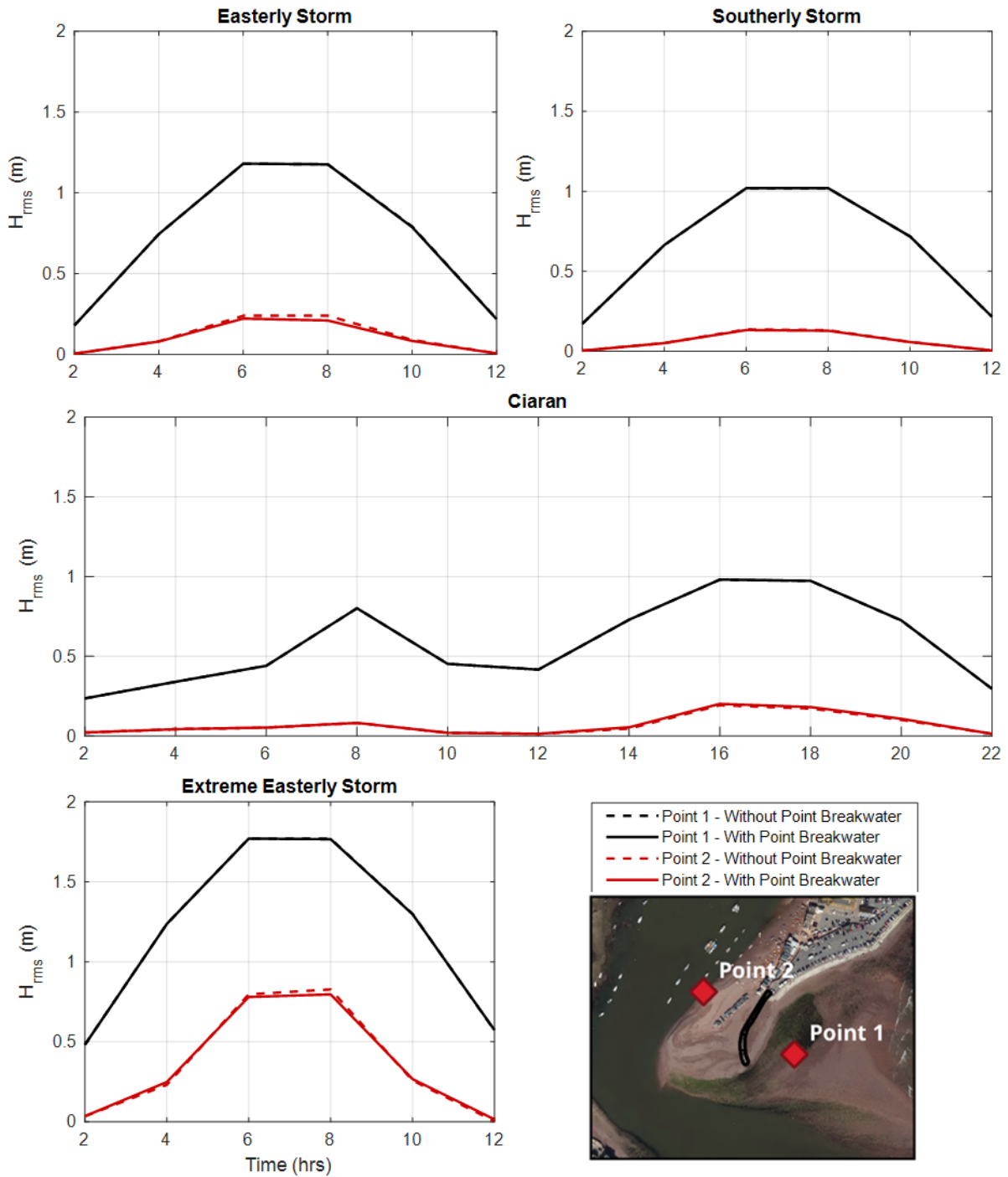

Figure E-10. Nearshore modelled wave heights (H_{rms}) either side of the Point for the four difference scenarios each with and without the breakwater in place.

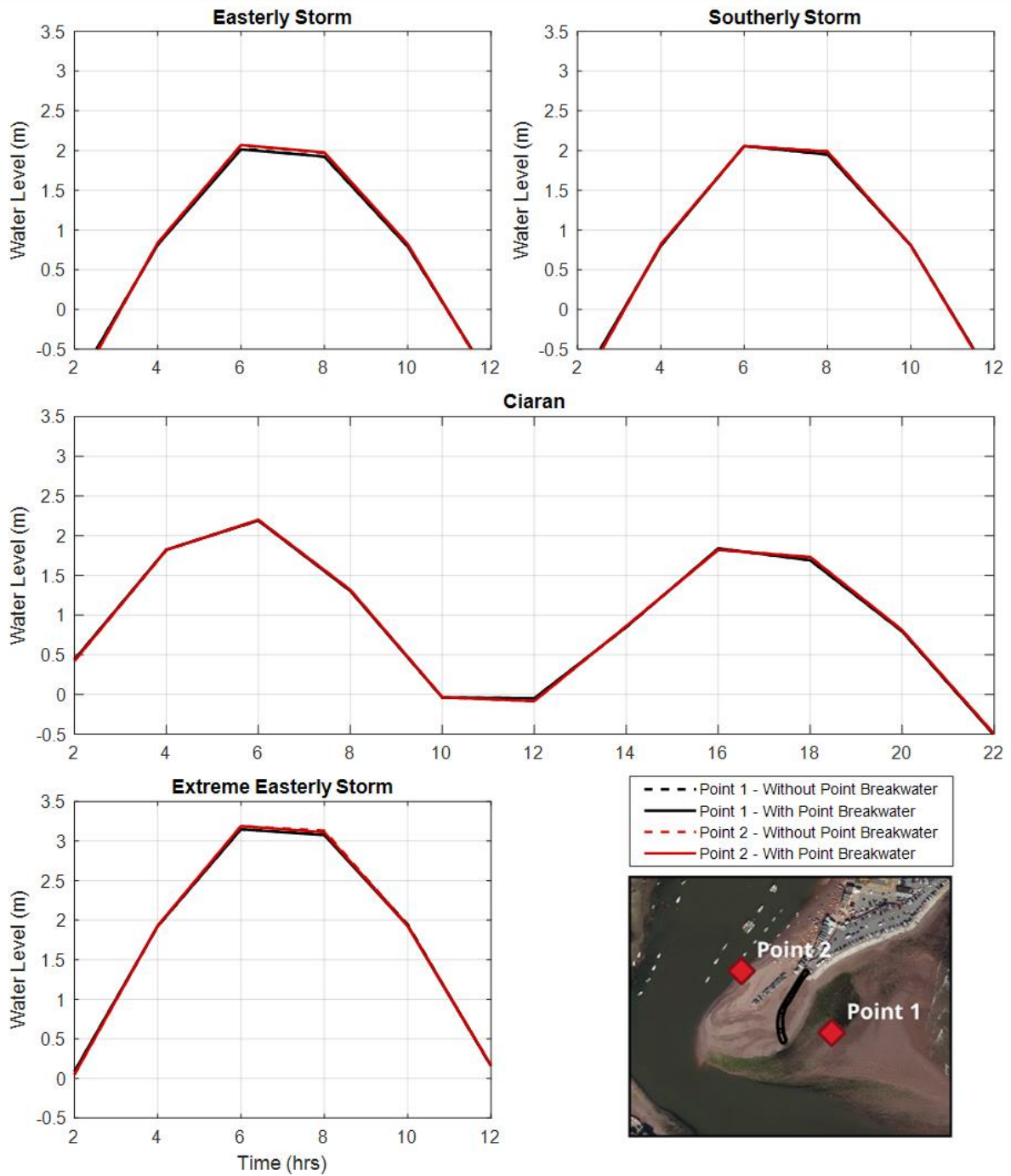

Figure E-10. Nearshore modelled water levels (mODN) either side of the Point for the four difference scenarios each with and without the breakwater in place.

References

Met Office. (2023). Storm Ciaran. Retrieved from
[https://www.metoffice.gov.uk/binaries/content/assets/metofficegovuk/pdf/weather/learn-
about/uk-past-events/interesting/2023/2023_09_storm_ciaran_2.pdf](https://www.metoffice.gov.uk/binaries/content/assets/metofficegovuk/pdf/weather/learn-about/uk-past-events/interesting/2023/2023_09_storm_ciaran_2.pdf)

Appendix B. Defences Baseline

Defences Baseline Report

Document no Baseline Defences Report
Version P03

Teignbridge District Council

Teignmouth Beach Management Plan
18 September 2025



Defences Baseline Report

Client name: Teignbridge District Council
Project name: Teignmouth Beach Management Plan
Project no: B2471100
Document no: Baseline Defences Report
Project manager: Emma Allan
Version: P03
Prepared by: Emily Marshall
Date: 18 September 2025
File name: Teignmouth BMP_Defences Baseline Report_P03

Document history and status

Version	Date	Description	Author	Checked	Reviewed	Approved
P01	17/5/24	Draft for Client review	E Marshall / M Stannard	E Marshall / M Stannard	J Eade	E Allan
P02	28/01/25	Minor updates, residual life updated for low maintenance & low beach levels.	E Marshall / M Stannard	E Marshall / M Stannard	E Allan	E Allan
P03	18/09/25	Final (minor formatting amendments)	E Marshall / M Stannard	E Marshall / M Stannard	E Allan	E Allan

Distribution of copies

Version	Issue approved	Date issued	Issued to	Comments
P03	EA	18.09.25	TDC	TDC review completed and comments addressed. Final for Client issue.

Jacobs U.K. Limited

Aperture @ Pynes Hill, Rydon Lane
Exeter, EX2 5AZ
United Kingdom

T +44 (0)139 226 9800
www.jacobs.com

© Copyright 2025 Jacobs U.K. Limited. All rights reserved. The content and information contained in this document are the property of the Jacobs group of companies ("Jacobs Group"). Publication, distribution, or reproduction of this document in whole or in part without the written permission of Jacobs Group constitutes an infringement of copyright. Jacobs, the Jacobs logo, and all other Jacobs Group trademarks are the property of Jacobs Group.

NOTICE This document has been prepared exclusively for the use and benefit of Jacobs Group client. Jacobs Group accepts no liability or responsibility for any use or reliance upon this document by any third party.

Contents

1. Introduction	6
1.1 Background and Study Area	6
1.2 The Basis of the Report	7
2. Defence History	8
2.1 Historic Coastal Defence Evolution	8
2.1.1 Teignmouth Open Coast	8
2.1.2 Teignmouth Back Beach	11
2.1.3 Shaldon	12
2.2 Current Defences	12
2.2.1 Teignmouth Open Coast	12
2.2.2 Teignmouth Back Beach	17
2.2.3 Shaldon	18
3. Condition Assessment & Residual Life	19
3.1 Visual Inspection	19
3.2 Condition Grading Methodology	19
3.3 Residual Life Estimation Methodology	20
3.3.1 Structural Failure due to Beach Lowering	21
3.4 Inspection Results	22
3.4.1 Teignmouth Open Coast – Concrete & Masonry Seawalls	22
3.4.2 Teignmouth Open Coast - Groynes	24
3.4.3 Teignmouth Back Beach – New Masonry Flood Walls	25
3.4.4 Teignmouth Back Beach – Historic Masonry Property Walls	26
3.4.5 Teignmouth Back Beach - Flood Gates	27
3.4.6 Teignmouth Back Beach - Demountable Defences	28
3.4.7 Teignmouth Back Beach - Concrete Seawalls	29
3.4.8 Shaldon – Concrete Seawall	30
3.4.9 Shaldon – Historic Masonry Seawalls	31
3.4.10 Shaldon – New Masonry Seawalls	32
3.4.11 Shaldon – Floodgates & Flood Boards	33
3.5 Summary	35
4. Wave Overtopping	36
4.1 Teignmouth Open Coast	37
4.2 Shaldon	37
5. Tidal Flooding	39
5.1 Determining Required Design Height	39
5.2 Floodgates	39
5.3 Floodwalls and Engineered High Ground	40

6. References42

Appendices

Appendix A. Condition Inspection by Asset.....43
Appendix B. Overtopping Assessment44

Tables

Table 3.1 Summary of AIMS assets by frontage. 19
 Table 3.2 General condition grades for structures from the Condition Assessment Manual (EA, 2012). 20
 Table 3.4 Summary of condition grade and residual life estimates grouped by frontage and asset type 35
 Table 4.1 Standard of protection at Teignmouth based on CH2M Hill (2014) overtopping rates and EurOtop (2007) and EurOtop II (2018) tolerable limits..... 37
 Table 4.2 Return period in which the overtopping rate reaches the threshold for the standard of protection in EurOtop II (JBA, 2021). 38
 Table 5.1 Required design heights to deliver a range of SoPs in 2024..... 39
 Table 5.2 Floodgate location, toe levels (Atkins, 2013) and crest levels (EA, 2024) and subsequent Standard of Protection for floodgates at the Teignmouth Back of Beach. 40
 Table 5.3 Floodwalls and Engineered High Ground location and Crest levels (EA, 2024) for floodgates at the Teignmouth Back of Beach..... 40

Figures

Figure 1.1 Extent of the defence assessment for Teignmouth and Shaldon.....6
 Figure 2.2 Summary of the coastal defence evolution at Teignmouth. 9
 Figure 2.5 Low beach levels between groynes 12 and 13 in December 1975 allowed exposure of concrete piles at the base of the seawall (Gundry, 1982). 10
 Figure 2.6 Flooding at Teignmouth Back Beach in 2008 (photo from Devon live, 2017)..... 12
 Figure 2.7 Location of the Groynes along the Teignmouth Coastline (CH2M, 2014). 13
 Figure 2.8 Spacing and Length of Groyne variation along the Teignmouth Open Coast..... 13
 Figure 2.9 Groyne Profile assumed from South West Water Authority (1977) for 60m and 36m groyne lengths..... 14
 Figure 2.10 Image of the Seawall near The Point Car Park. 14
 Figure 2.11 Cross section of the seawall seaward facing from the Point Car park (Binnies, 2023). 15
 Figure 2.2.12 Seawall located behind groyne 12 with a cross section of the groyne (Binnies, 2023) 15
 Figure 2.14 Seawall cross located behind groyne 7 (Binnies, 2023). 16
 Figure 2.15 Defence protecting the railway line between Sprey Point and East Cliff..... 17
 Figure 2.16 Construction of reinforced concrete floodwalls with masonry facing as part of the Teignmouth flood defence scheme (R. Scott 2012)..... 17

Figure 2.17 Construction of reinforced concrete flood walls with masonry facing as part of the Teignmouth flood defence scheme (R. Scott 2012)..... 18

Figure 2.18 Two different seawall types found at Shaldon..... 18

Figure 4.1 Profiles from JBA (2021) and BMP (2014)- Shaldon to the pier at Teignmouth. 36

Figure 4.2 Profiles from JBA (2021) and BMP (2014)- From the pier at Teignmouth to the railway. 36

1. Introduction

This review of existing coastal defences has been undertaken to establish a baseline for the Teignmouth to Shaldon Beach Management Plan (BMP). This review has been undertaken to provide an update to the defences assessment undertaken as part of the previous BMP in 2014 (CH2M Hill, 2014).

1.1 Background and Study Area

Teignmouth is located at the mouth of the river Teign, on the South-East coast of Devon. The coastal defences for this assessment have been examined along the town of Teignmouth and village of Shaldon, at the mouth of the Teign Estuary.

For the purpose of this study the frontage was divided into three areas as shown in Figure 1.1:

- Teignmouth open coast- between Sprey Point and The Point car park.
- Teignmouth back-beach- between The Point and Associated British Ports (ABP).
- Shaldon - between The Ness public house and the Clipper Café.

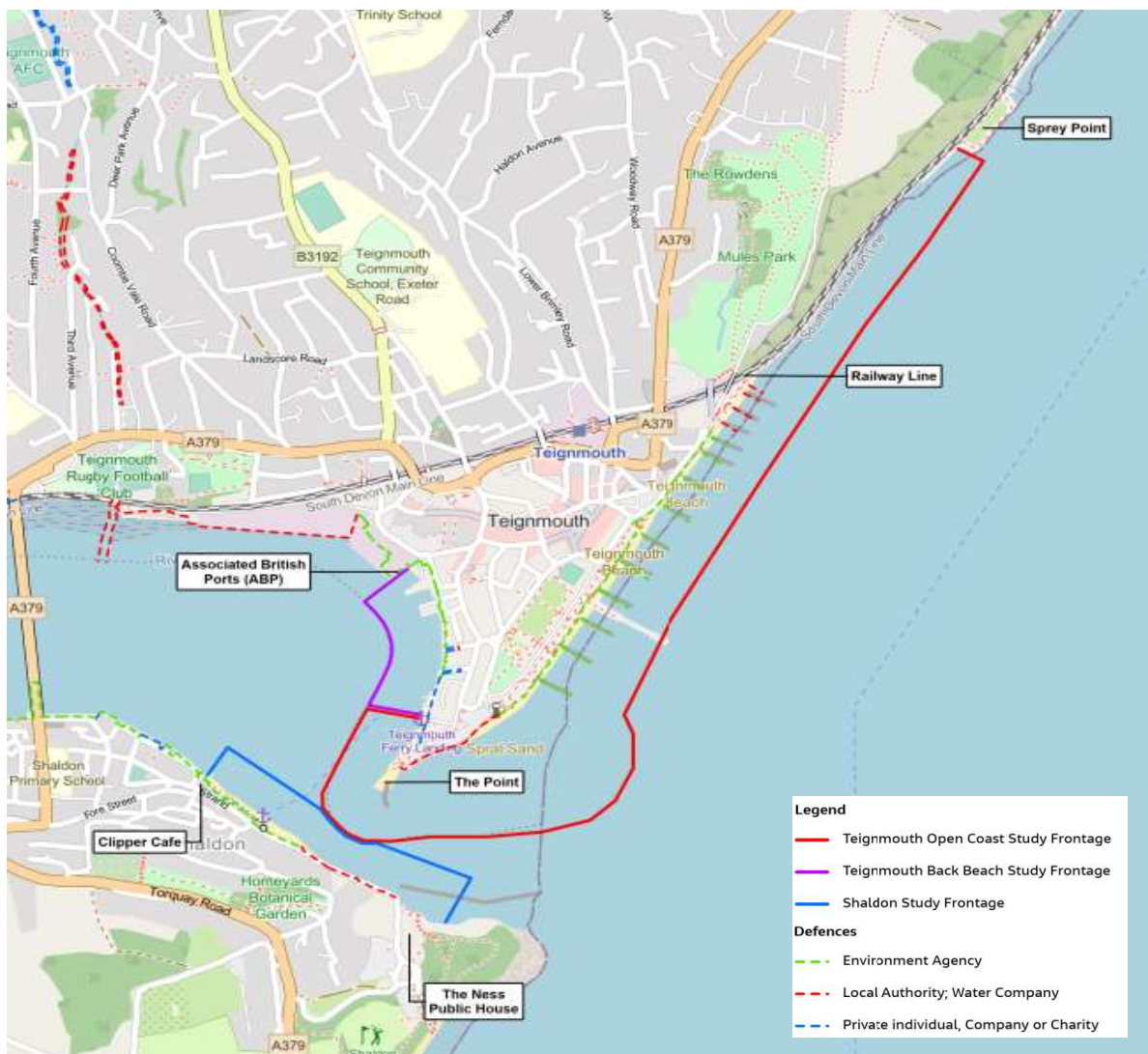

Figure 1.1 Extent of the defence assessment for Teignmouth and Shaldon.

Behind the immediate shoreline of Teignmouth and Shaldon the land is used for a mixture of residential and commercial properties, general amenity and shipping activities. As a result of the historic high value of tourism to both Teignmouth and Shaldon, there are also a number of amenity facilities along the shorelines including berthing facilities, restaurants, Teignmouth lido, a mini gold course and tennis/multi-purpose court. The shoreline also forms a part of the Southwest Coast Path. Based on a Jacobs (2024b) assessment of the economics, present value damage are estimated at £116.5 million and £3.1 million for Teignmouth and Shaldon respectively.

1.2 The Basis of the Report

This report provides details of the defences located along the Teignmouth and Shaldon frontages including information from previous studies and reports (listed in the references section, see Section 6) that have been reviewed as part of this project. The purpose of this report is to provide an up-to-date assessment of the existing defences and the standard of protection they provide now and in the future with sea level rise.

2. Defence History

2.1 Historic Coastal Defence Evolution

2.1.1 Teignmouth Open Coast

Teignmouth and Shaldon is home to 17,000 people protected by a range of coastal defences (City Population, 2025a and 2025b). The evolution of these coastal defences began in Teignmouth in 1845 with the construction of the lighthouse at the harbour entrance and subsequent construction of a seawall in 1867.

In 1906, a river training wall was constructed of masonry, extending from under the present Point Car Park in a radiused arc to seaward. It is understood that the purpose of the structure was to hold the sands back from impinging on the inner channel (Harbour Master / Martin Davies, *Pers. Comms.*, 2024). The structure was originally constructed of granite and masonry, and later capped by concrete (Graeme Smith, *Pers. Comms.*, 2011). Although now mostly buried, the cap is visible on the beach today. Today, the structure acts to retain sediment at The Point, resulting in an increased width of the beach there, as demonstrated by the photos in Figure 2.1, which show The Point in 1936 and in 2024. It is possible that the structure acts to reduce wave exposure in the estuary during storms, when it is over washed/breached during storms (for example Storm Ciaran in 2013), but this is not known for certain. Additional modelling has been undertaken for this BMP to look into the effects that the The Point could have on water levels and wave heights in the Teign Estuary.



Figure 2.1 Photos showing differences in sand accumulation around The Point breakwater, left: photo from c 1963-4 (Binnes, 2024), and right: Teignmouth BMP site visit photo from 2024.

Due to the force (from waves and water levels) exhibited on the coastline, adjustments to these initial structures have occurred along with the addition of further structures to reduce coastal flooding. A summary of these changes can be seen in Figure 2.2.

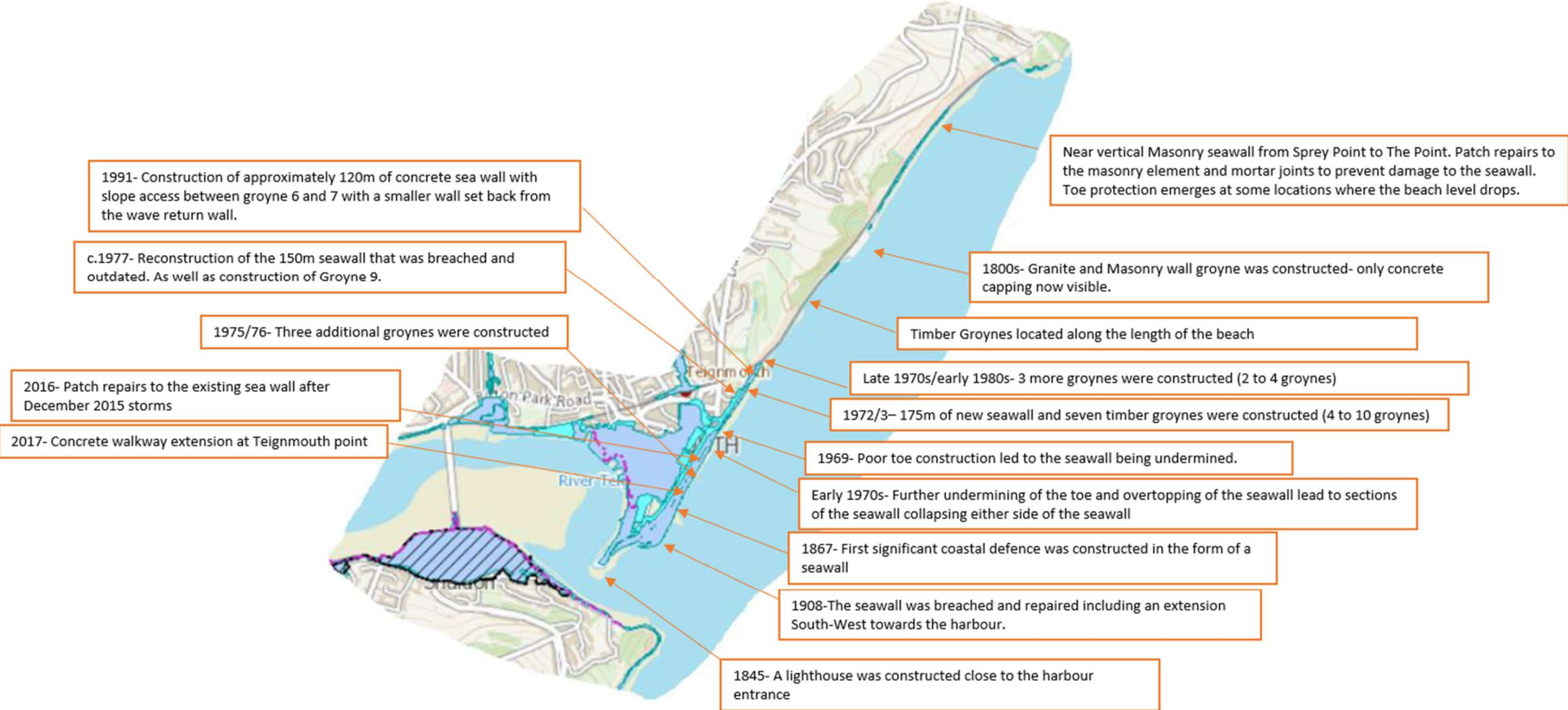

Figure 2.2 Summary of the coastal defence evolution at Teignmouth.

Historic photographs showing a selection of the construction of and as-built defences are presented in Figure 2.3, Figure 2.4 and Figure 2.5.



Figure 2.3 Flood defences under construction at Denn Promenade, November 1972 (Gundry, 1982).



Figure 2.4 Groyne 11, with elevated beach level, in November 1974 (Gundry, 1982).



Figure 2.5 Low beach levels between groyne 12 and 13 in December 1975 allowed exposure of concrete piles at the base of the seawall (Gundry, 1982).

2.1.2 Teignmouth Back Beach

Although coastal wave action does not directly impact Teignmouth Back Beach due to the sheltered location, the low level of the surrounding land is at increased risk to inundation from the sea due to rising sea levels caused by climate change. This is not to say, however, that Teignmouth Back Beach does not experience some smaller waves from the sea or from the river fetch. Indeed, as noted below, wave action has been known to contribute to flooding. Regarding recent flood events, records show that:

- In December 1989, the back beach overtopped causing significant flooding within the town (depths of up to 0.6m) and storm damage.
- In September 1992, Teignmouth town centre experienced up to 0.1m of surface water flooding in Teign Street. There was no reported property damage but the cause of the flooding was believed to be due to the tide locking of surface water drainage outlets.
- In February 1995, Teignmouth town centre flooded again from a resulting tidal surge.
- In 2003, a project appraisal was undertaken by the Environment Agency which recommended improving the Back Beach tidal defences. The proposals were opposed by the local community, primarily on the grounds of visual impact and disruption of access to the foreshore and quays, resulting in the scheme being withdrawn from the capital programme.
- In October 2004, a 0.9m storm surge resulted in a 3.1-3.2mOD observed tide (Atkins, 2013) which is above the doorway thresholds of Teign View Place properties along Back Beach. Records suggest that 12no. properties were flooded. Despite this much damage, the estimated return period of this event was only a 1 in 17 (6%) event (Atkins,2013). However, extreme water level analysis carried out as part of State of the Nation would put such a level at around 1 in 50 years (2% AEP).
- In April 2006, the Town Council held a public consultation which showed clear community support for a tidal defence scheme to be re-considered. The subsequent result of this was for reinstatement of the Back Beach tidal defences into the capital programme.
- In March 2008, a 0.7m storm surge resulted in a 3.0mOD observed tide. This equates to a 1 in 5 flood level (Atkins, 2013), however, extreme water level analysis carried out as part of State of the Nation would put such a level at around 1 in 10 (10% AEP). This resulted in some flooding to 10 properties along Back Beach due to wave action. Wrack marks caused by lines of debris indicating the high water level were evident on the roads leading from Back Beach.
- In 2013, 14 new flood gates and 73m of flood walls were constructed along existing property walls, as well as 157 linear metres of new independent flood wall were incorporated as part of the Teignmouth Flood Defence Scheme. New public access ramps and demountable flood boards were incorporated in the flood walls. Properties along the Back Beach were also provided more comprehensive protection. See Section 2.2.2 for more information on this.



Figure 2.6 Flooding at Teignmouth Back Beach in 2008 (photo from Devon live, 2017).

2.1.3 Shaldon

Documentation relating to the historical defences along the Shaldon shoreline is sparse, potentially as a consequence of increased protection offered by the more sheltered geographical position on the south bank of the River Teign. The smaller village size relative to Teignmouth, and the smaller amount of commercial activities in the area may also account for the fewer number of flood defence schemes enacted. The types of flood defence constructed along the Shaldon frontage are different from those found along the Teignmouth shoreline, due to differences in assets and flood risk.

The defences along the Shaldon shoreline are more variable than those along the Teignmouth shoreline, with evidence of multiple stages of construction and repair to the defences. The flood defences between the Ness headland and the main beach at Shaldon are characterised by concrete structures and masonry walls of different materials and dimensions. The rapid variation in defence type, and general smaller size of the works suggests that the expenditure has generally been smaller on this frontage, and in a more ad-hoc manner.

The beach along the main Shaldon shoreline acts as a primary defence to the town and has received periodic recharge and re-profiling to maintain a beach structure that can provide the necessary flood protection (CH2M, 2014).

Shaldon Village was protected from flooding by the construction of Shaldon and Ringmore Flood Defence Scheme that was completed in 2011 and comprises a consistent flood wall defence level along the main village shoreline. This is achieved with short sections of wall protecting both the road parallel to the river and the series of private properties, with flood gates and steps across the wall providing access where necessary.

2.2 Current Defences

2.2.1 Teignmouth Open Coast

At present the Teignmouth open coast defences comprise a concrete and rock masonry seawall protecting the town and the railway to the north-east, along with a series of timber groynes along the main Teignmouth town shoreline (as seen in Figure 2.7). A sand and shingle beach exists along much of the shoreline.

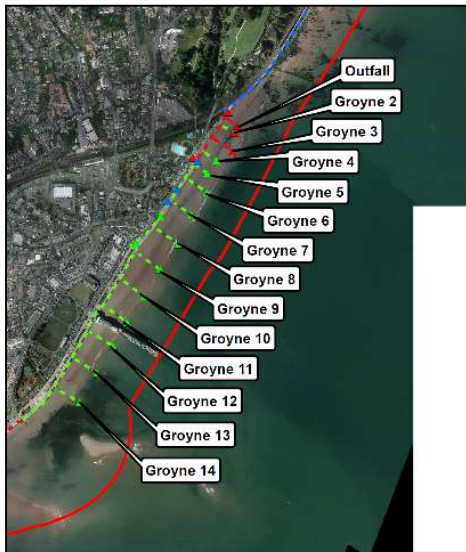

Figure 2.7 Location of the Groynes along the Teignmouth Coastline (CH2M, 2014).

All the groynes are constructed from timber. However, the specific detail of the construction varies along the shoreline reflecting the different building phases, as shown in Figure 2.8.

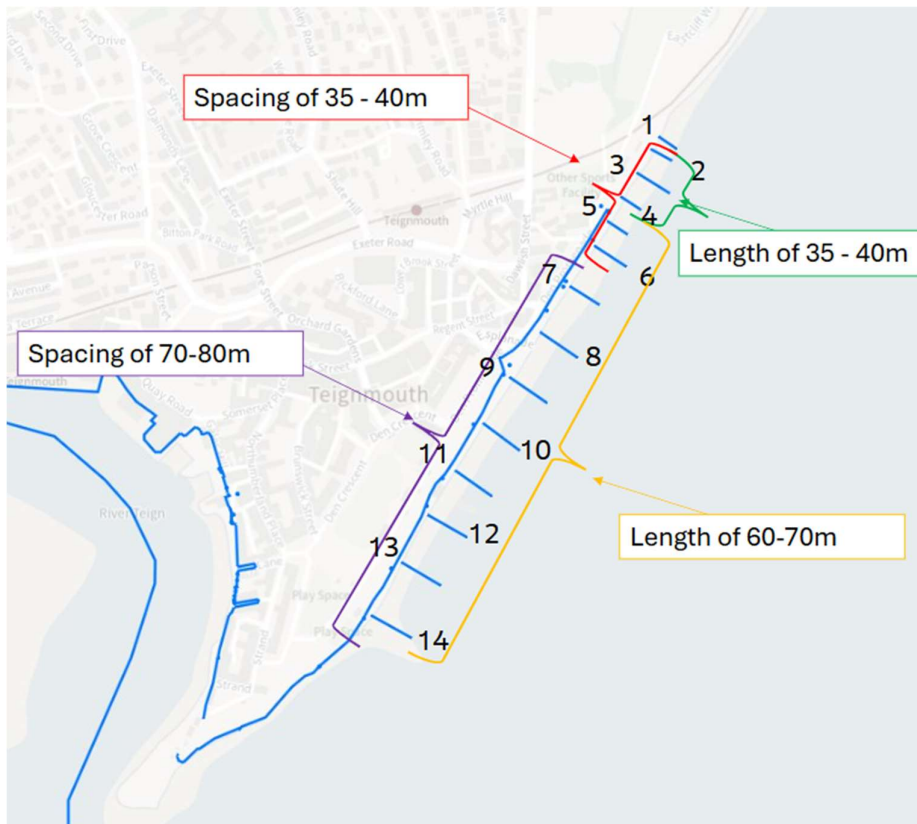

Figure 2.8 Spacing and Length of Groyne variation along the Teignmouth Open Coast.

Length variation changes the profile of the groynes along the beach. Although as-builts are not available for the built groynes, proposed groynes from December 1977 (South West Water Authority, 1977) have been used to predict the designed groyne profile. The groyne profiles universally start landward at the concrete

steps and then slope at a 1 in 11 slope. Where the groynes are smaller in length the profiles terminate at the desired length, whereas, in the case of the longer 60-70m groynes, the slope changes around 0.0mODN and -0.5mODN to a flatter 1 in 22 slope until desired length has been achieved. This is sketched in Figure 2.9.

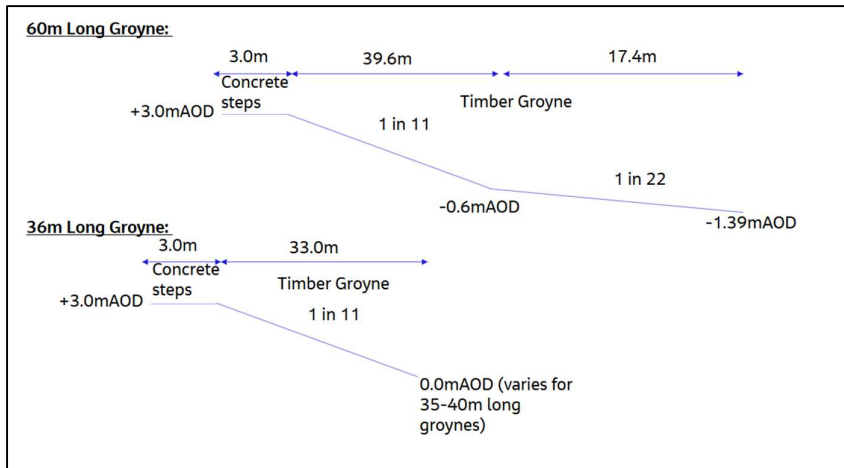

Figure 2.9 Groyne Profile assumed from South West Water Authority (1977) for 60m and 36m groyne lengths.

At the southwestern extent of the groyne field a large number of planks across the upper beach have been removed. This was initially done to allow plant access to move beach material alongshore the foreshore and to allow for easy access along the shoreline for the public, although the planks have not since been reinstated.

The seawall along the coastline consists of 4 different sections. Near The Point Car Park the seawall is a granite facing vertical wall with a walkway located halfway up its height. This can be seen in Figure 2.10 and Figure 2.11.



Figure 2.10 Image of the Seawall near The Point Car Park.

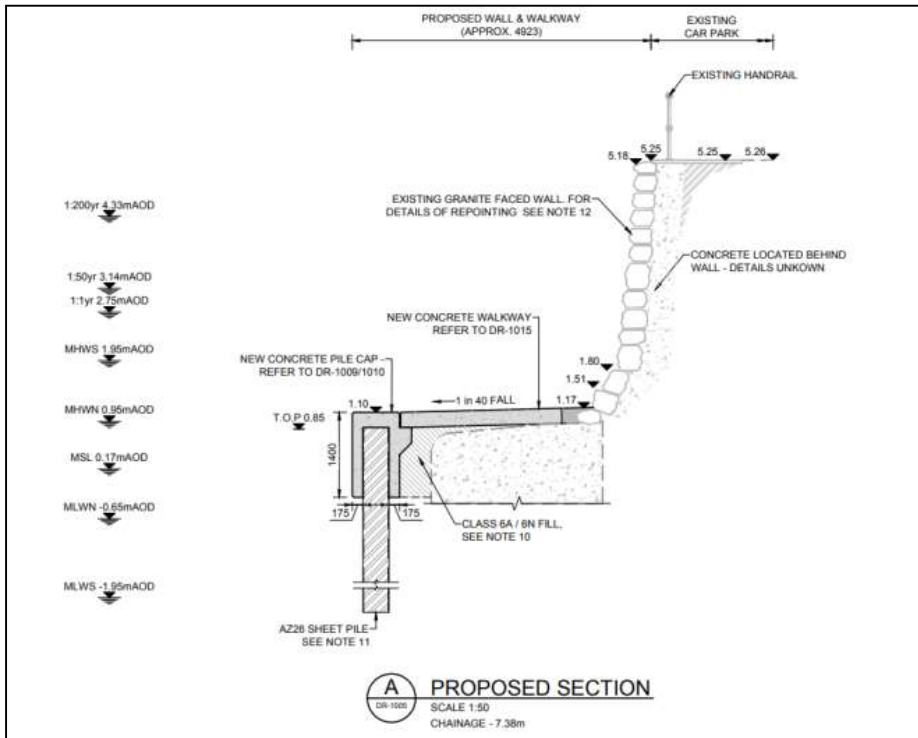

Figure 2.11 Cross section of the seawall seaward facing from the Point Car park (Binnies, 2023).

The seawall near groyne 12 consists of a bullnose, concrete steps and a sheet pile toe. The sheet pile toe in this section has become more exposed due a decrease in beach crest level. This can be seen in Figure 2.2.12.



Figure 2.2.12 Seawall located behind groyne 12 with a cross section of the groyne (Binnies, 2023)

The rebuilt seawall from 1977 adjoins the previous section around the Esplanade, comprising of a large wave return wall and stepped concrete toe protection. This section is positioned further from the seaward and has a lower initial crest level, though also includes a small wall further behind the crest to reduce flooding to the town.

A section of rock-faced concrete seawall provides flood defence between Saint Michael's Church and Groyne 9, as shown in Figure 2.13. This defence largely continues the structural profile of the previous concrete section with a wave return wall, and a set-back smaller flood protection wall. The cross section of which is shown in Figure 2.13.



Figure 2.13 Rock-faced, concrete seawall constructed in the mid 1970's.

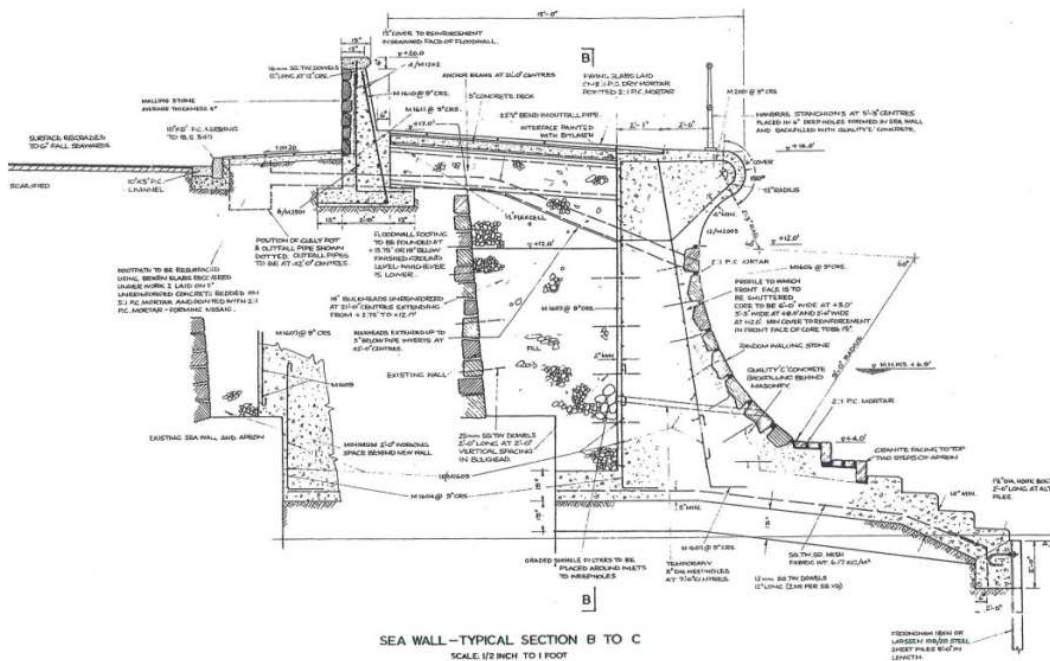

Figure 2.14 Seawall cross located behind groyne 7 (Binnies, 2023).

A surface water outfall pipe owned by Southwest Water is also located at the northern end of the beach. This consists of a steel pipe encased in concrete. Despite its function as an outfall pipe this is referred to as groyne no. 1.

Further north towards Teignmouth Lido, the older seawall adjoins the previous section. The seawall has some replacement masonry blocks and patch repairs to the masonry elements, and replacement of the mortar joints to prevent further damage to the seawall. Toe protection emerges at some specific locations where the beach level drops, and this also shows some signs of patched repair and maintenance works. This section of wall is owned by Network Rail.



Figure 2.15 Defence protecting the railway line between Sprey Point and East Cliff.

2.2.2 Teignmouth Back Beach

The current 2012 flood defence scheme at the Back Beach includes flood gates, masonry clad reinforced concrete flood walls and demountable flood boards. The adjoining historic properties along Back Beach were also provided more comprehensive protection against flooding including air bricks, flood defence doors, flood defence windows and glazing panels. Further resurfacing of the road/public seating area was also part of the scheme to ensure no worsening of the surface water flood risk. Some photos of the construction stage of this scheme are provided in Figure 2.16 and Figure 2.17.



Figure 2.16 Construction of reinforced concrete floodwalls with masonry facing as part of the Teignmouth flood defence scheme (R. Scott 2012).



Figure 2.17 Construction of reinforced concrete flood walls with masonry facing as part of the Teignmouth flood defence scheme (R. Scott 2012).

As part of the scheme the Flood Warning Direct (FWD) (EA, 2010) was deployed. The FWD is an automated voice messaging flood warning system allowing for the early warning of extreme tidal events.

An automated telephone flood warning service is available to residents in Teignmouth to obtain help and to alert the authorities of flooding. An emergency plan exists for evacuation of the town centre in the event of extreme coastal flooding.

2.2.3 Shaldon

The existing defences at Shaldon comprise sections of seawall. There are no groynes present for beach stabilisation. Working in a northwestern direction from beneath The Ness public house towards Shaldon village, the flood defences are formed by an assortment of different seawalls constructed at different times and exhibiting different levels of maintenance and repair. These seawalls are either concrete, masonry, or a combination of the two, and primarily provide flood and erosion protection to the adjacent road, Marine Parade. Examples of seawalls at Shaldon are shown in Figure 2.18.



Figure 2.18 Two different seawall types found at Shaldon.

3. Condition Assessment & Residual Life

The purpose of the condition assessment is to provide an up-to-date visual inspection of the coastal defences along the project frontage to assess their current condition and estimate their residual life. For the purpose of the inspection the Environment Agency's Asset Information Management System (AIMS)

(<https://environment.data.gov.uk/asset-management/>) was used to categorise the defences into individual assets types.

3.1 Visual Inspection

Visual inspection of the coastal defence assets was undertaken on Friday 23rd February 2024 between 10:30am and 2:30pm by a Chartered coastal engineer and assistant engineer. The inspection was timed to coincide with the low tide window to maximise access and visibility of the structures. The weather at the time of the survey was 6°C with scattered clouds, occasional heavy showers with light winds and calm sea state.

Predicted tides on the day of the survey were

- Low Tide 1.28mCD at 12:02am
- High Tide 3.97mCD at 16:35pm

The inspection was divided into the three areas as shown in Figure 1.1. Along the Teignmouth Open Coast frontage, the inspection excluded the seawall assets along the railway line since these are owned by Network Rail. Along the Teignmouth Back Beach frontage, the inspection excluded flood defence assets located within the secure area of Associated British Ports (ABP). Along the Shaldon frontage, the riverward limit of the inspection was at Shaldon Quay flood gate 6 adjacent to the Clipper Café. A summary of AIMS assets for each of these frontages is provided in Table 3.1.

Table 3.1 Summary of AIMS assets by frontage.

Frontage Name	Approx. Length	Asset Numbers	Defence Description
Teignmouth Open Coast	1,180m	19no.	Concrete and masonry seawalls with sheet piled toe. 14no. timber groynes.
Teignmouth Back Beach	600m	29no.	Various concrete and masonry flood walls, masonry property walls, 8no. flood gates, 1no. demountable flood board and property level protection.
Shaldon	630m	14no.	Concrete, brick and masonry seawalls. 5no. flood gates, 2no. demountable flood boards.
TOTAL	2,410m	62no.	

3.2 Condition Grading Methodology

Assessment of asset condition was undertaken using the same visual inspection approach adopted for the previous Beach Management Plan (CH2M, 2014), using the Environment Agency's Condition Assessment Manual (EA, 2012). This guidance provides a set of visual indicators based on the specific failure mechanism for that structure to assess its integrity and performance. The assessment includes visible surface defects and the asset's surroundings only and excludes below water elements or buried foundation. These indicators allow a condition grade to be determined for each asset ranging from 'Very Good' to 'Very Poor', as described in Table 3.2. More detailed asset specific descriptions are available in the Condition Assessment Manual.

Table 3.2 General condition grades for structures from the Condition Assessment Manual (EA, 2012).

Grade	Rating	Description
1	Very Good	Cosmetic defects that will have no effect on performance.
2	Good	Minor defects that will not reduce the overall performance of the asset.
3	Fair	Defects that could reduce the performance of the asset.
4	Poor	Defects that would significantly reduce performance of the asset.
5	Very Poor	Severe defects resulting in complete performance failure.

3.3 Residual Life Estimation Methodology

Assessment of the residual life for all coastal defence structures was undertaken in accordance with the Environment Agency's Practical Guidance on Determining Asset Deterioration and the Use of Condition Grade Deterioration Curves (EA, 2013). This guidance provides a standardised approach to assessing and quantifying the deterioration of flood and coastal defence assets based on models that determine the progression of an asset's condition through the five condition grade states (as defined in the Condition Assessment Manual). These models provide high level estimates only, intended to be used in decisions of long-term strategic investment; regional asset management and budgeting; and for planning of maintenance scheduling. Estimates of residual life of assets was not included in the previous BMP (CH2M, 2014) and therefore no comparison can be made.

Using these deterioration curves, the number of years until complete performance failure (transition from current condition grade to condition grade 5 Very Poor) has been determined based on the following factors

- **Environment** The environment which influences the asset being either fluvial or coastal. To classify correctly, consideration should be given to the presence of wave loading, salt environment and daily water level variation.
- **Material** The type of material that the asset is made of. For the Teignmouth and Shaldon frontages asset material types include concrete, brick/masonry and timber as well as metal flood gates.
- **Asset type** Such as vertical walls, sheet piles, groynes, flood gates and demountable defences.
- **Maintenance Regime.** Residual life guidance includes three maintenance regimes:
 - **Low/basic** Which is a do-minimum approach.
 - **Medium** Which is an average approach including minor reactive repairs to maintain at condition grade 3 Fair [target grade for EA assets].
 - **High** To maintain assets at condition grade 2 Good [not considered].
- **Deterioration Rate.** The following environmental exposure classes are used to determine the deterioration rate for the assets
 - **Slowest** Arising from a sheltered location and/or high-quality materials and construction, well-designed asset.
 - **Medium** Considered a typical rate providing a mid-range value representing an average situation, with assets being neither exposed nor sheltered.
 - **Fastest** Arising from an exposed location and/or poor-quality materials, construction or design.

In addition, the Condition Assessment Manual also recommends applying engineering judgement and practical experience to adapt the deterioration curves to be more specific to individual site situations, as required. In particular this has been applied to the residual life of the demountable defences at Teignmouth

Back Beach and Shaldon, where damage curves for Low Maintenance (Do Nothing) unrealistically reduced the residual life to 3 to 5 years. Assuming the aluminium flood boards are left in place under a Do Nothing scenario the residual life has been increased to 15 to 20 years which considers seals failing, as-hoc damage and unauthorised removal.

3.3.1 Structural Failure due to Beach Lowering

Experience of this coastline has shown that erosion and lowering along some of the open coast sections of is likely to be a key mechanism affecting the stability of the coastal defence structures increasing the probability of failure of the seawalls. To assess the potential for early failure due to beach lowering the Teignmouth Coastal Defences Engineering Assessment (Binnies, 2024) has been used to identify the beach level required to give a factor of safety of 1.0 (i.e. for failure to be likely). This engineering assessment was undertaken with and without toe piles but reports that since *“the calculations made without toe piles indicated Area 4B would have failed at the minimum beach level recorded, this provides confidence assumed that the toe piles retain sufficient structural integrity to be effective”* and that *“visual inspection of the exposed toe piles did not indicate extensive corrosion that might be of concern at this time”*. For these reasons only critical low beach levels with toe piles has been used. Table 3.3 provides an extract from Binnies (2024) Table 6 showing critical beach levels for failure.

Table 3.3 Extract from Binnies, 2024 Table 6 showing critical beach levels for structural failure.

Location on Teignmouth Open Coast	Area 2	Area 3	Area 4a	Area 4b	Area 5	Area 6
AIMS Asset ID	177501		177697		57776	
Beach profile	N/A		6b00209		6B00212	6B00216
Beach level for FoS = 1.0 (m ODN)	-3.5	-0.3	-1.25	-1.25	-4.0	-3.7

Using the values presented above and results from the Coastal Processes Baseline Assessment (CMAR, 2024) (Figures 8-1 to 8-5 showing predicted beach levels over time), an estimate of when this critical low beach level will occur has been determined. An example chart is presented in Figure 3.1. Upper and lower limits of the 95% confidence bounds have been used to estimate a range of values where the structure is likely to fail early due to beach lowering.

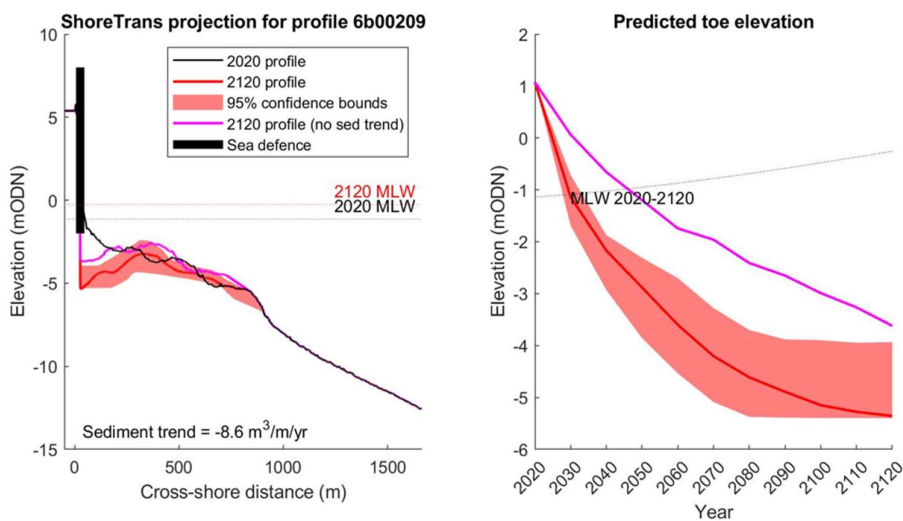

Figure 3.1. Extract from CMAR, 2024 showing example chart showing predicted beach level at seawall toe.

Since data for structural failure is only available for the seawalls along the Teignmouth open coast (Binnies, 2024) and the coastal processes baseline assessment (CMAR, 2024) only identifies beach lowering at the

southern end of this frontage, this assessment of structural failure due to beach lowering is limited to a number of structures only.

3.4 Inspection Results

For each individual asset a detailed description of its condition, estimate of condition grade and residual life, along with asset location maps and general photos are provided in Appendix A. A summary description is provided below, grouped by frontage and asset type.

For a more detailed assessment of the structural stability of the seawalls along the Teignmouth open coast frontage refer to the Teignmouth Coastal Defences Engineering Assessment by Binnies (draft April 2023).

3.4.1 Teignmouth Open Coast – Concrete & Masonry Seawalls

AIMS Asset ID 57776, 177697, 177501, [No. AIMS Asset No.]

Frontage Description A seawall extends along the 1.2km of Teignmouth open coast frontage consisting of 4 different wall types including masonry walls, concrete recurve walls and masonry clad concrete walls. These seawalls extend from the estuary mouth in the south to the junction with the railway line in the north (seawalls further north along the railway line are owned by Network Rail and excluded from this inspection).

Condition Description No structural movement evident in any of the walls. Very low beach levels at southern end exposing approx. 2m height of sheet piles along masonry wall toe. Exposed height continues along approx. 50m of sheet piled toe of concrete recurve wall. Minor surface corrosion and loss of protective paint system evident to exposed sheet piles. Heavy abrasion evident along the exposed stepped toe and access steps to the concrete recurve wall south of the Pier. At the centre of the frontage beach levels continue to increase completely burying toe steps by groyne no.10. Minor cracks visible at the centre of most bays in the concrete recurve wall, likely thermal shrinkage cracks at the time of construction. Minor areas of spalling at movement joints and missing sealant from many expansion joints. Damage to a short section of masonry facing near groyne no.7 with stones missing along approximately 5m length.

Condition Grade 2 (Good) to 3 (Fair)

Residual Life (fastest exposure rate) 20 to 30 years - if 'Medium' maintenance
15 to 25 years - if 'Low' Maintenance
5 to 11 years - (for asset 17697) considering beach lowering

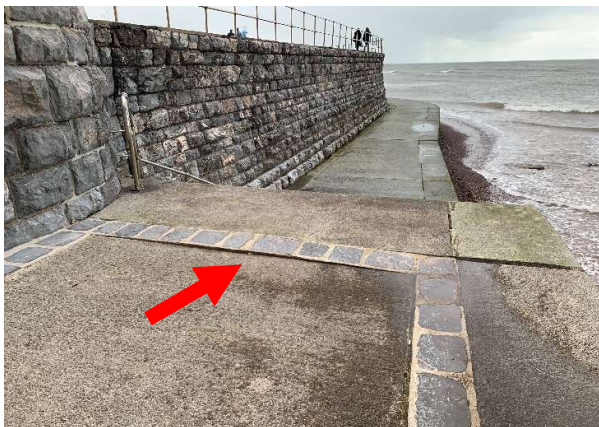

57776 Lifting of areas of infill masonry in between concrete slabs.



57776 Loss of paint system and surface corrosion of toe piles. Loss of majority expansion joint sealant.

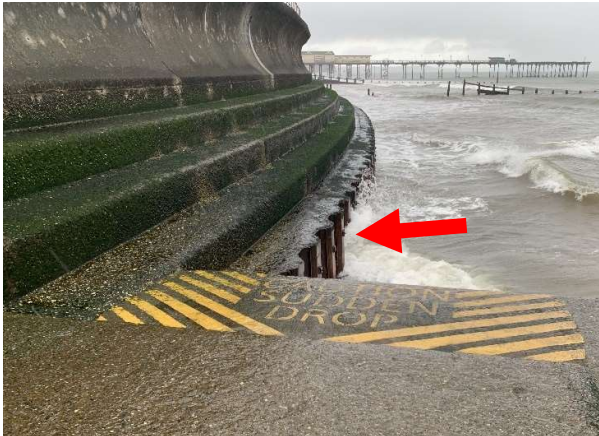

177697 Low beach levels exposing sheet piled toe.



177697 Heavy abrasion of concrete toe and steps.



177697 Loss of expansion joint sealant at most joints.



177697 Vertical cracks in upper recurved section of wall at mid-point of many wall sections.



177501 Upper concrete bullnose and masonry facing in good condition, high beach levels.



177501 Localised loss of section of masonry facing at northern end of wall exposing concrete backing.

At northern end, high beach levels prevent high tide reaching the wall. Majority of stone blocks and mortar joints in reasonable condition, no evidence of any cracked or missing blocks, except for large section of concrete repair at Teign Corinthian Yacht Club which has horizontal cracking along construction joints.



No AIMS Asset ID. Masonry blocks sound, minor abrasion to mortar joints.



No AIMS Asset ID. Small horizontal cracks between construction joints at repaired section of wall.

3.4.2 Teignmouth Open Coast - Groynes

AIMS Asset ID 327116, 327115, 327085, 327084, 327083, 327082, 327081, 327080, 327079, 327078

Frontage Description A total of 14no. groynes are located along the Teignmouth open coast frontage, 13no. timber and one concrete encased steel outfall pipe. These groynes are typically 60 - 70m long with a typical spacing of 70 - 80m, with the exception of groynes 2 - 4 at the northern end of the beach which are only 35 - 40m long, and groynes 2 - 6 which have a reduced spacing of 35 - 40m.

Condition Description All groynes along the Teignmouth open coast frontage are in poor condition with heavy abrasion throughout splitting of some posts and many planks damaged or missing. Very low beach levels at the south end around groynes no. 12 - 14. No evidence of any groynes being effective at retaining beach material. Posts generally remain vertical with only very minor rotation of some posts evident. Most planks across the vehicle access gap in the upper beach missing. Planks that remain are heavily abraded with large gaps between. Many fixings damaged or missing, some evidence of repairs to fixings on groyne no.13.

Condition Grade 4 (Poor)

Residual Life (fastest exposure rate) 2 years - if 'Medium' maintenance
<2 years - if 'Low' Maintenance

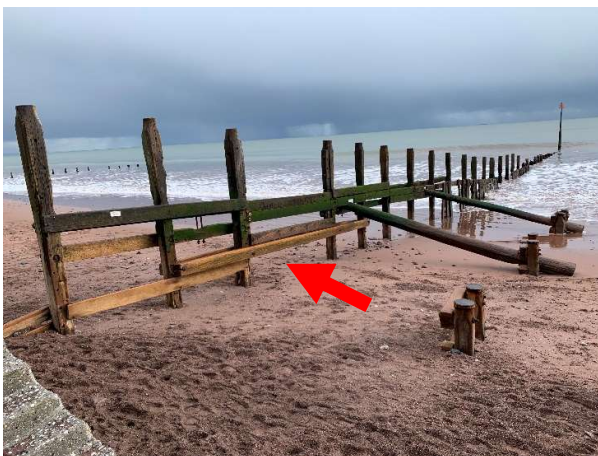

327115 Many groynes missing planks with large gaps between planks that remain.



327117 Heavy abrasion of posts and planks with gaps showing between boards.



327084 Most posts vertical with only minor rotation evident. Many posts split and cracked.

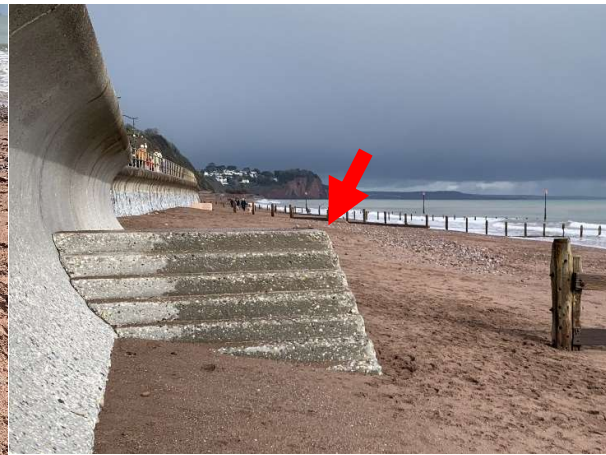

327085 Heavy abrasion to most concrete steps over groynes. Handrailing present on some steps but most missing.

3.4.3 Teignmouth Back Beach – New Masonry Flood Walls

AIMS Asset ID 392717, 180688, 392733, 10148, 180673, 392777, 392781

Frontage Description New reinforced concrete (RC) masonry faced flood walls constructed in 2012 located along the northern extent of the frontage at Gates Hill Road, and in front of the Ship Inn Public House. Other masonry walls that form part of flood defences along this frontage include historic masonry walls of properties, largely located along the central and southern part of the frontage at The New Quay Inn, and properties between Ivy Lane and Forrester Terrace.

Condition Description The new RC masonry faced flood walls are generally in good condition with no evidence of structural movement, damage, missing masonry blocks or gaps in mortar joints. All expansion joints sealant is well bonded with no signs of cracking. No damage to glazing panels, all seals intact, some rot to lintels.

Condition Grade 2 (Good Condition)

Residual Life (slowest exposure rate) 80 years - if 'Medium' maintenance
65 years - if 'Low' Maintenance



180688 No gaps or cracks in masonry or mortar joints in new walls constructed.



180688 Joint sealant in new masonry walls remains in good condition with no signs of debonding or cracking.



392781 Waterproof glazing panels in good condition. 392781 Seals to floodproof glazing panels intact. Some rot evident in lintles.

3.4.4 Teignmouth Back Beach – Historic Masonry Property Walls

AIMS Asset ID 392716, 392734, 4142, 42304, 180630, 3935, 392776, 392779, 392780, 181119

Frontage Description The rendered masonry wall forming the flood defence at the New Quay Inn Public House is located along the back of a wide sandy beach at around high tide level. This defence includes wooden sash windows that do not appear to be flood proof. This flood defence continues across the back of the quay at Garstone Garden Ornaments which is well set back from the sea. The remaining flood walls between Ivy Lane and Forrester Terrace, provided by boundary walls to the property gardens, are located along the back of a narrow sandy beach around at around high tide level.

Condition Description No evidence of structural movement in any masonry property walls. All masonry blocks generally sound with no signs of missing blocks or cracks (apart from two short sections of missing coping at asset No.392776). All mortar joints are generally sound with no significant cracks or gaps. Some lowering of beach levels between Ivy Lane and Forrester Terrace exposing the concrete toe and causing localised undermining up to 0.6m.

Condition Grade 2 (Good) to 3 (Fair)

Residual Life (slowest exposure rate) 40 to 80 years - if 'Medium' maintenance
35 to 65 years - if 'Low' Maintenance



392734 Property wall of the New Quay Public House in good condition, windows do not appear to be floodproof.



4142 Flood defence alignment appears to run through the Garstone Garden Ornaments property. Not inspected.



392776 Masonry blocks and mortar joints good, two short sections of missing coping stones.

Evidence of beach lowering and some undermining of toe of masonry boundary wall.

3.4.5 Teignmouth Back Beach - Flood Gates

AIMS Asset ID 392714, 392718, 392732, 392735, 392752, 392754, 392774, 392778

Frontage Description There are 8no. single and double hinge flood gates (5no. vehicle and 3no. pedestrian) located along the estuary frontage between the ABP Port area and The Point at the mouth of the estuary. These flood gates were constructed as part of the Teignmouth Flood Alleviation Scheme in 2012.

Condition Description All components appear present and functioning. No corrosion to hinges, all gates appear to be in good working order although not operated at time of inspection. Gates and frames appear in good alignment. No damage to any sills. Some rubber seals showing minor signs of distress and cracking, with delamination evident on one seal (flood gate No.12). Most timber facings have minor signs of splitting and rot along base, although these elements appear aesthetic only and are not expected to reduce the performance of the asset.

Condition Grade 2 (Good)

Residual Life (slowest exposure rate): 22 years - if 'Medium' maintenance
17 years - if 'Low' Maintenance



392735 No corrosion to hinges which appear to be in good working order.

392735 No damage evident to sills which appear to provide a good sealing face.



392754 Minor cracking evident to most rubber seals, with some delamination of one seal (flood gate No.12).

392718 Minor splitting and rot along bottom of aesthetic facing timber to most gates.

3.4.6 Teignmouth Back Beach - Demountable Defences

AIMS Asset ID 524451, 42304

Frontage Description Short section of demountable flood defence (22m) along top of masonry flood wall fronting the Ship Inn Public House. Constructed as part of the Teignmouth Flood Defence Scheme in 2012. Posts and planks not installed at time of inspection. Boards assumed to be metal due to narrow width of slots in end channel. Flood proof doors installed to 13no. properties along back of beach between Queens Street and Ivy Lane as part of 2012 scheme.

Condition Description All post caps and end channels appear in very good condition. No flood boards present at time of survey so not possible to assess condition. Narrow sandy beach between Queens Street and Ivy Lane with evidence of high tide line close to properties. All 13no. flood proof doors to properties along back of beach in good condition, evidence of one door having been replaced.

Condition Grade 2 – Good

Residual Life (slowest exposure rate) 60 years - if 'Medium' maintenance
20 years - if 'Low' Maintenance



524451 All post caps and hold down bolts present and in very good condition.



524451 End channels secure and in very good condition.



42304 Narrow beach between Queens Street and Ivy Lane with high tide mark near flood defence line of properties.



42304 All flood proof doors to property defence line along back of beach in good condition.

3.4.7 Teignmouth Back Beach - Concrete Seawalls

AIMS Asset ID 3934

Frontage Description The southernmost asset along the Teignmouth Back Beach is a 150m long concrete wall. This wall extends along the back of the beach with steps leading to a public walkway along the crest. Situated at the back of this walkway are the masonry property walls of Morgans Quay containing low level doors (standard, not floodproof) and openings / walk-throughs. A narrow sandy beach is located along the toe of the wall along with a concrete pier with steps and a ramp. The walls gets submerged at high tide. The exact level and alignment of the flood defence through this area is unclear.

Condition Description Evidence of minor cracking and spalling of render. Narrow sandy beach with evidence of high tide against the structure, evidence of lowering of beach levels at flapped outlet surround and localised undermining of toe up to 0.5m deep.

Condition Grade 3 - Fair

Residual Life (medium exposure rate) 30 years - if 'Medium' maintenance
20 years - if 'Low' Maintenance



3934 Minor cracks evident in concrete wall but render largely intact along northern end.



3934 Some cracking and spalling evident in concrete render, beach lowering and localised undermining of toe.



3934 No gaps or damage to timber boards or hand railings along crest of concrete wall.



3934 Concrete quay and steps fronting Morgans Quay properties with low levels doors and openings through properties.

3.4.8 Shaldon – Concrete Seawall

AIMS Asset ID N/A

Frontage Description The seawall at the easternmost end of the frontage consists of a number of different structures broadly consisting of a lower concrete wall and toe supporting an upper masonry wall and grassed embankment.

Condition Description Cracks in concrete throughout and spalling of rendering. Heavy abrasion of Spraycrete facing exposing reinforcement bars, and abrasion along concrete toe and steps. Voids opening in construction joint along toe. Most flap valves missing. Masonry wall along crest largely ok but cracks between in-situ slabs above. Erosion of soft grassed bank above wall at southern end, previous geotextile bag repair in good condition.

Condition Grade 3 (Fair)

Residual Life (medium exposure rate) 30 years - if 'Medium' maintenance
20 years - if 'Low' Maintenance



No AIMS Asset ID Low beach levels and undermining of toe.



No AIMS Asset ID Heavy abrasion and voids opening in toe. Most flap valves missing.



No AIMS Asset ID Cracks in concrete and rendering, some sections of concrete broken and missing.



No AIMS Asset ID Erosion of grass bank as southern end of wall.

3.4.9 Shaldon – Historic Masonry Seawalls

AIMS Asset ID 84539, 84538

Frontage Description From The Ness public House the historic stone masonry seawalls run along the western edge of the estuary along Marine Parade Road until the first properties at Shaldon House. These walls have a concrete toe beam running along their full length. The beach fronting these sections of wall is very low with the toe of the walls submerged at high tide.

Condition Description No signs of structural movement. Masonry is generally sound with no cracks or missing blocks, with the exception of the wall adjacent to Shaldon House where the masonry is heavily abraded and has many brickwork repairs which remain in reasonable condition. Mortar joints are generally sound with no cracks or gaps. Evidence of beach lowering along most of the length, with signs of undermining at the southern end with concrete fill repairs underway at the time of the inspection.

Condition Grade 3 (Fair)

Residual Life (medium exposure rate) 30 to 55 years - if 'Medium' maintenance
20 to 40 years - if 'Low' Maintenance



84539 Evidence of undermining of concrete toe, concrete fill repairs underway at time of inspection.



84539 Abrasion along concrete toe and localised cracks and missing sections of some concrete.



84538 Masonry blocks generally in good condition with no cracks or gaps in mortar.



84538 Heavy abrasion to masonry blocks along some sections of wall, especially at toe, many brickwork repairs but in reasonable condition.

3.4.10 Shaldon – New Masonry Seawalls

AIMS Asset ID 84537, 84540, 82711, 82710

Frontage Description From Shaldon House to the Clipper Café new masonry seawalls were constructed in 2011 as part of the Shaldon and Ringmore Tidal Defence Scheme. The beach in front of this section is generally very wide with the majority of the walls well above the high tide line. The first section of wall up to Horse Lane includes a promenade and setback wall. From Horse Lane the defence line steps out around the gardens along the estuary side of The Strand Road and is made up of a narrower boundary wall. These walls finish at the Pier adjacent to The Clipper Café where they tie into a flood gate (flood gate No.6).

Condition Description No signs of structural movement. All masonry in good condition with no cracks or gaps in mortar joints. Low beach levels along a short stretch of wall at the southern end near the outfall resulting in localised undermining of the toe, up to 0.9m deep. Remaining beach levels very wide and high resulting in the rest of the wall being well set back from the high tide level.

Condition Grade 2 (Good)

Residual Life (medium to slowest exposure rate)

55 to 80 years - if 'Medium' maintenance
40 to 65 years - if 'Low' Maintenance



84537 Low beach levels at southern end of wall near outfall resulting in localised undermining up to 0.9m deep.



84537 High beach levels along promenade, concrete surfacing and masonry setback wall in good condition.



82711 Masonry blocks in good condition, no cracking or gaps in mortar joints, all flap valves present and working.
 82719 Masonry blocks in good condition, no cracking or gaps in mortar joints, all flap valves present.

3.4.11 Shaldon – Floodgates & Flood Boards

AIMS Asset ID 332938, 332936, 332937, 332935, 332934, 332933, 332932

Frontage Description There are 5no. single hinge flood gates (2no. vehicle, 3no. pedestrian) located between Horse Lane and The Clipper Café. These were constructed as part of the Shaldon and Ringmore Tidal Defence Scheme in 2011.

Condition Description No evidence of corrosion. All hinges appear to be in good working order, although gates not operated at time of inspection. Gates appears to be in good alignment with frame. Seals covered behind locked protective flaps so not possible to inspect. No evidence of damage to sills. Timber facings in very good condition. Channels for flood boards in good condition, some loss of paint, boards were not present at time of inspection so excluded from the assessment.

Condition Grade 2 (Good)

Residual Life (slowest exposure rate) 22 to 50 years - if 'Medium' maintenance
 15 to 17 years - if 'Low' Maintenance



332933 No corrosion to hinges, all appear to be in good working order.

332938 No damage evident to sills, all sealing faces appear in good condition.



332934 Timber facings to all gates in good condition, no evidence of rot.



332936 Some loss of paint to aluminium channels for flood boards.

3.5 Summary

A summary of condition grade and residual life estimates grouped by frontage and asset type is presented in Table 3.4.

Table 3.4 Summary of condition grade and residual life estimates grouped by frontage and asset type

Frontage / Asset Type	Condition Grade	Exposure Rate	Residual Life (years)		
			Maintenance Regime		Beach lowering
			'Medium'	'Low'	
<u>Teignmouth Open Coast</u>					
Seawalls	2 (Good) / 3 (Fair)	Fastest	20 to 30	15 to 25	5 to 11
Groynes	4 (Poor)	Fastest	2	2	N/A
<u>Teignmouth Back Beach</u>					
New Masonry Flood Walls	2 (Good)	Slowest	80	65	N/A
Historic Masonry Property Walls	2 (Good) / 3 (Fair)	Slowest	40 to 80	35 to 65	N/A
Flood Gates	2 (Good)	Slowest	22	17	N/A
Demountable Defences	2 (Good)	Slowest	60	20	N/A
Concrete Seawalls	3 (Fair)	Medium	30	20	N/A
<u>Shaldon</u>					
Concrete Seawalls	3 (Fair)	Medium	30	20	N/A
Historic Masonry Seawalls	3 (Fair)	Medium	30 to 55	20 to 40	N/A
New Masonry Seawalls	2 (Good)	Medium / Slowest	55 to 80	40 to 65	N/A
Floodgates & Flood Boards	2 (Good)	Slowest	22 to 50	15 to 17	N/A

4. Wave Overtopping

An assessment of wave overtopping has been undertaken for Teignmouth Open Coast and Shaldon frontages. Profile locations investigated are provided in Figure 4.1 and Figure 4.2. Overtopping analysis from JBA (2021) and CH2M Hill (2014) has been considered as a way to indicate the current, 50-year and 100-year standard of protection. Overtopping limits from EurOtop II (2018) and EurOtop (2007) have been used to determine public safety and structural limits, respectively.

A summary of the findings of this analysis are provided below, further details are provided in Appendix B.



Figure 4.1 Profiles from JBA (2021) and BMP (2014)- Shaldon to the pier at Teignmouth.

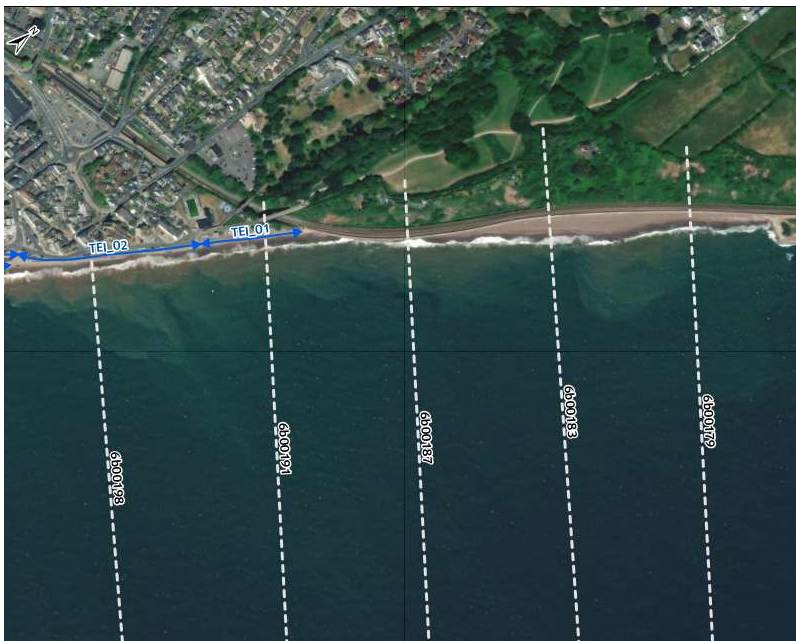

Figure 4.2 Profiles from JBA (2021) and BMP (2014)- From the pier at Teignmouth to the railway.

4.1 Teignmouth Open Coast

Royal Haskoning DHV (2014) determined that overtopping increased negligibly/minimally from 2013 to 2014. Changes since then are likely not sufficient to alter the assessment of SoP. For future epochs, while the previous BMP analysis used old climate projections (UKCP09), the calculated overtopping rates were higher than those of the JBA analysis (2021) which used the latest projections (UKCP18). Therefore, the results are still likely to be conservative.

Table 4.1 Standard of protection at Teignmouth based on CH2M Hill (2014) overtopping rates and EurOtop (2007) and EurOtop II (2018) tolerable limits.

Section Name		Present Day (2014)		2062		2112	
JBA (2021)	BMP (2014)	Structural SoP	Public Safety SoP	Structural SoP	Public Safety SoP	Structural SoP	Public Safety SoP
TEI_01	6b00191	1 in 200	1 in <1	1 in 10	1 in <1	1 in 5	1 in <1
TEI_02	6b00198	1 in 500	1 in <1	1 in 200	1 in <1	1 in 100	1 in <1
TEI_03	6b00204	1 in 500	1 in 10	1 in 200	1 in 1	1 in 10	1 in <1
TEI_04	6b00216	1 in 50	1 in <1	1 in 10	1 in <1	1 in 1	1 in <1
TEI_07	6b00212	1 in 50	1 in <1	1 in 1	1 in <1	1 in <1	1 in <1
TEI_08	6b00204	1 in 500	1 in 10	1 in 200	1 in 1	1 in 10	1 in <1

Note Red text denotes where the SoP is below a 1 in 200yr RP event and therefore insufficient.

As is shown in Table 4.1, a number of the sections calculated above are deemed to provide an insufficient SoP. Particular cross sections of concern are TEI_04 (which reaches the limit under present day conditions), TEI_01 (which reaches the limit for public safety in the present day and then structurally in 2062) and TEI_07 (which reaches the limit under present day conditions). TEI_02, TEI_03 and TEI_08 reached the structural limit in the year 2112 but reach the limit for public safety in the present day, 2062 and 2112 respectively.

4.2 Shaldon

The Shaldon coastline on the South side of the River Teign was not considered in the previous BMP analysis (CH2M Hill, 2014) due to a lack of beach profile data. As such, JBA modelling has been adopted to determine the various standards of protection, as shown in Table 4.2.

Table 4.2 Return period in which the overtopping rate reaches the threshold for the standard of protection in EurOtop II (JBA, 2021).

Section Name		Overtopping Discharge (l/s/m)					
JBA (2021)	BMP (2014)	Present Day		2070		2120	
		Structural SoP	Public Safety SoP	Structural SoP	Public Safety SoP	Structural SoP	Public Safety SoP
TEI_05	SHALDON	1 in >1000	1 in 20	1 in >1000	1 in <200	1 in >1000	1 in <200
TEI_06	SHALDON	1 in >1000	1 in 200	1 in >1000	1 in <200	1 in >1000	1 in <200

Since JBA (2021b) have not conducted an overtopping assessment in the year 2070 and 2120 for return periods other than 1 in 200 and 1 in 1000 years, commentary can only be made as to whether the overtopping limits have been reached for those conditions. In the case of TEI_05, it is reasonable to suggest that the SoP for public safety will be less than 1 in 20-year return period for the year 2070 and 2120 based on the return period conditions in the present day.

Based on the results from JBA (2021b) it is unlikely that overtopping will be the cause of structural failure along this coastline.

As with the previous BMP (2014), no profile monitoring data is available along the Shaldon frontage. Therefore, no checks can be made on the levels provided in JBA (2021) with which the overtopping rates have been calculated. For profiles along the Teignmouth open coast some of these levels were found to be related to the overall coastal flood inundation, rather than structural overtopping which is required for assessment of the standard of protection. The results should therefore be considered as indicative only.

To allow a more detailed assessment of overtopping rates and standard of protection along the Shaldon frontage it is recommended that profile monitoring along the Shaldon is required to improve data collections at Shaldon.

5. Tidal Flooding

An assessment of tidal flood risk has been undertaken for the Teignmouth Back Beach Frontage. Due to the geography of the Teignmouth Back Beach, this coastline will not experience coastal wave conditions and the subsequent energy caused from direct exposure to the sea. The beach here is located at a low level and therefore has suffered with tidal flooding due to the increase of sea water levels in the estuary basin. As such, it is unlikely that wave overtopping will contribute significantly to flooding in this area.

The Teignmouth Back beach is currently protected by the 2011 Teignmouth Flood defence scheme in which new flood protection structure were issued along the coastline. Please refer to Section 2.2.2 for more information.

5.1 Determining Required Design Height

Water levels have been analysed using Coastal Flood Boundary data (EA, 2017) from 2017 and transformed to present day (2024) by Jacobs. These levels, combined with a wave allowance and freeboard (obtained from Atkins, 2013) have been used to determine the required design height to provide a range of SoPs in 2024. These are presented in Table 5.1. Note, the original aim of the scheme was to provide the coastline with a 1 in 1000-year SoP in 2013.

Table 5.1 Required design heights to deliver a range of SoPs in 2024.

Standard of Protection (year)	EWL (mAOD)	Wave Allowance (m)	Freeboard Allowance (m)	Design Height (mAOD)
2	2.89	0.42	0.225	3.53
5	2.99	0.42	0.225	3.63
10	3.07	0.42	0.225	3.71
20	3.15	0.42	0.225	3.79
30	3.17	0.42	0.225	3.81
40	3.19	0.42	0.225	3.83
50	3.24	0.42	0.225	3.88
75	3.28	0.42	0.225	3.92
100	3.31	0.42	0.225	3.95
150	3.35	0.42	0.225	3.99
200	3.38	0.42	0.225	4.02
500	3.46	0.42	0.225	4.10
1000	3.52	0.42	0.225	4.16

5.2 Floodgates

Levels of the top of the floodgates have been obtained using AIMS data (EA, 2024) accessed in April 2024. It is unknown when this information was added to the AIMS database or the original source of the information. Toe levels of the gates have been obtained from Atkins (2013) and corroborated with the AIMS database (EA, 2024).

The crest and toe levels and location of the flood gates are presented in Table 5.2.

Table 5.2 Floodgate location, toe levels (Atkins, 2013) and crest levels (EA, 2024) and subsequent Standard of Protection for floodgates at the Teignmouth Back of Beach.

Gate	Location	Toe Level (mAOD)	Crest Level (mAOD)	SoP
7	Gales Hill Gate	3.37	4.155	500 Year
8	Osmond's Lane	3.24	4.295	1,000 Year
9	Osmond's Ramp	2.602	4.157	500 Year
10	New Quay North	3.267	4.215	1,000 Year
11	New Quay South	3.302	4.157	500 Year
12	Back Beach Access Ramp	2.878	4.168	1,000 Year
13	Coast Guard Access	2.8	4.155	500 Year
14	6 Marine Terrace	3.083	4.168	1,000 Year

Note Red text denotes where the SoP is below a 1 in 1000 yr RP event and therefore insufficient.

Based on the updated water level conditions this report determines that the current SoP, assuming water level variation change only from Atkins (2013), remains as the designed SoP of 1 in 1000-years for most of floodgates with a few slightly failing the new 1 in 1000-year criteria (these are highlighted in red).

5.3 Floodwalls and Engineered High Ground

Levels of the top of the floodwalls and engineered high ground have been obtained using AIMS data (EA, 2024) accessed in April 2024. It is unknown when this information was added to the AIMS database or the original source of the information.

The crest and AIMS asset numbers for the Floodwalls and engineered high ground can be found in

Table 5.3.

Table 5.3 Floodwalls and Engineered High Ground location and Crest levels (EA, 2024) for floodgates at the Teignmouth Back of Beach.

Asset number	Description	Crest Level (mAOD)	SoP	Comments
392717	Pumping station wall	4.12	500 Year	
392716	Masonry wall	4.155	1,000 Year	
180688	Masonry wall	4.15	500 Year	
392733	Masonry wall	3.855	20 Year	AIMS (EA,2024) indicates the SoP is 1000 years but level indicates a SoP of 20 years.
392734	Masonry property wall	4.155	1,000 Year	
4142	Masonry property wall	4.155	1,000 Year	

Defences Baseline Report

10148	Masonry wall	4.155	1,000 Year	
180673	Masonry wall with glazing	4.155	1,000 Year	
42304	Wall	4.155	1,000 Year	
392783	Engineered high ground	3.54	1 Year	Temporary flood protection measures would be required in order to achieve the design level set out in Atkins (2013)
3935	Wall	4.155	1,000 Year	
180630	Wall	3.63	2 Year	Despite the low wall level the house behind has been reinforced to protected against flooding.
392776	Masonry property wall	4.155	1,000 Year	
392777	Masonry property wall	4.155	1,000 Year	
392779	Masonry property wall	4.155	1,000 Year	
392780	Masonry property wall	4.155	1,000 Year	
392782	Engineered high ground	3.63	2 Year	Temporary flood protection measures would be required in order to achieve the Design level set out in Atkins (2013)
181119	Rendered property wall	3.63	2 Year	Despite the low wall level the house behind has been reinforced to protected against flooding.
392781	Masonry wall with glazing	4.155	1,000 Year	
3934	Concrete wall	2.79	<1 Year	Temporary flood protection measures would be required in order to achieve the Design level set out in Atkins (2013)
<i>Note Red text denotes where the SoP is below a 1 in 1000 yr RP event and therefore insufficient.</i>				

For the purpose of calculating the standard of protection, the structure has been considered as an individual unit without any additions such as demountable flood boards. In the most part, the flood defence systems seem to be providing the desired 1 in 1000-year protection other than the ones highlighted in red in

Table 5.3. Areas of particular tidal flood risk are structures located towards the mouth of the River and areas of engineered high ground.

6. References

Atkins, 2013. Teignmouth (Back Beach) Tidal Defence Scheme (IMSW 000780) - CDM Regulations Health & Safety File, Revision 1, 3rd Issue.

Binnies, 2024. Teignmouth Coastal Defences Engineering Assessment, For Information, Project No.4020285, prepared by Binnies for the Environment Agency, 4020906-BUK-ZZ-TCV-RP-Z-00008, October 2024.

CH2M, 2014. Teignmouth and Shaldon Beach Management Plan, prepared by CH2M Hill for Teignbridge District Council, May 2014.

City Population, 2025a. Teignmouth using Census data from 2021. URL [Teignmouth \(Parish, United Kingdom\) - Population Statistics, Charts, Map and Location](#) Accessed last on 20th January 2025.

City Population, 2025b. Shaldon using Census data from 2021. URL [Shaldon \(Devon, South West England, United Kingdom\) - Population Statistics, Charts, Map, Location, Weather and Web Information](#) Accessed last on 20th January 2025.

CMAR, 2024, Teignmouth Beach Management Plan, Coastal Processes Baseline Assessment, version 2005_d1v2, by Coastal Marine Applied Research (CMAR) May 2024.

Devon Live, 2017. Flashback Storm damage in Devon through the years URL <https://www.devonlive.com/news/devon-news/gallery/flashback-storm-damage-devon-through-62717> Accessed on 7th May 2024

EA, 2010, Project Appraisal Report, Teignmouth Estuary (Back Beach) Tidal Defence Scheme

EA, 2012. Condition Assessment Manual, Environment Agency, March 2012.

EA, 2013. Practical guidance on determining asset deterioration and the use of condition grade deterioration curves Revision 1, Report – SC6078/R1, Environment Agency, June 2013.

EA, 2017. Coastal Flood Boundary Data. URL [Coastal flood boundary conditions for the UK 2018 update - GOV.UK \(www.gov.uk\)](#)

EA, 2024. Asset Information and Maintenance System (AIMS). URL <https://environment.data.gov.uk/asset-management/> Accessed on 10th April 2024.

Gundry, S., 1982. A consideration of harbour improvements and sea defence in Teignmouth, Devon, BSc. Thesis, Aberystwyth University College of Wales, Aberystwyth

Jacobs, 2024a. Water Level analysis for CFBD at chainage 4844, and UKCP18 RCP 8.5 70th percentile sea level rise.

Jacobs 2021b. Economics Baseline, Version 1.









JBA, 2021. Devon and Cornwall Coastal Flood Risk Modelling-Model Development Report, Version 4.0





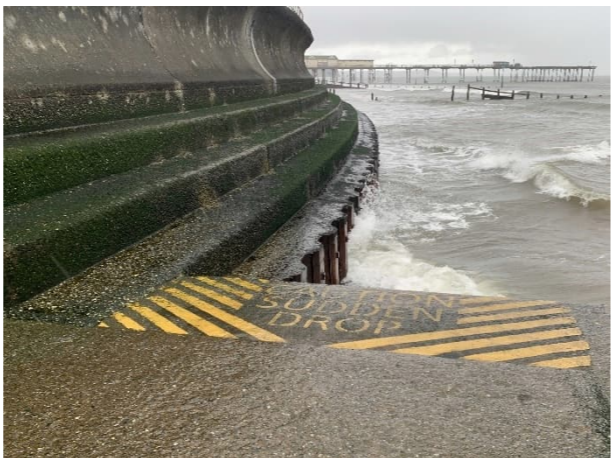

South West Water Authority, 1997. Layout of Groynes 15,16 and 17, Preliminary-Not Built. Drawing No. TE/6/35

Van Oord, 2016. Typical Cross section of Teignmouth Seawall Emergency Repair Works



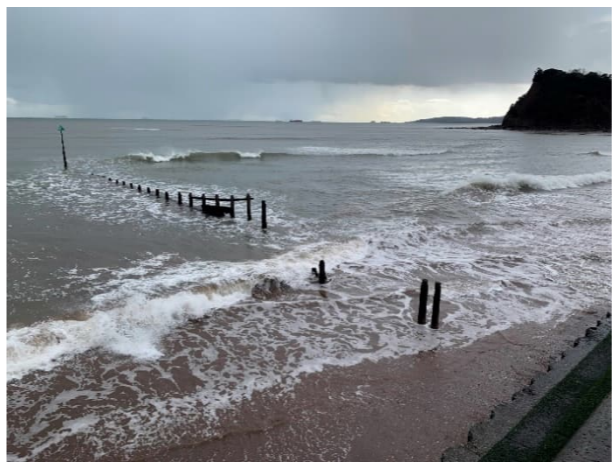
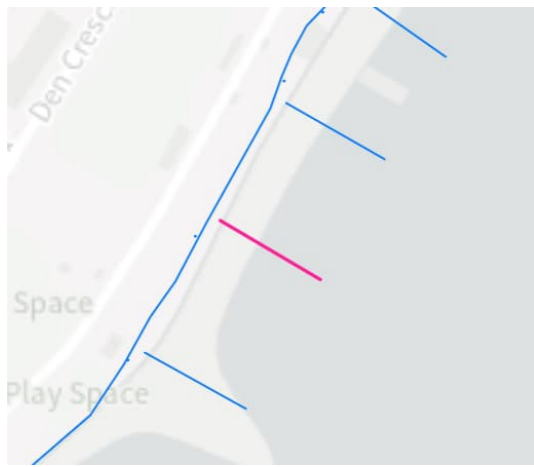
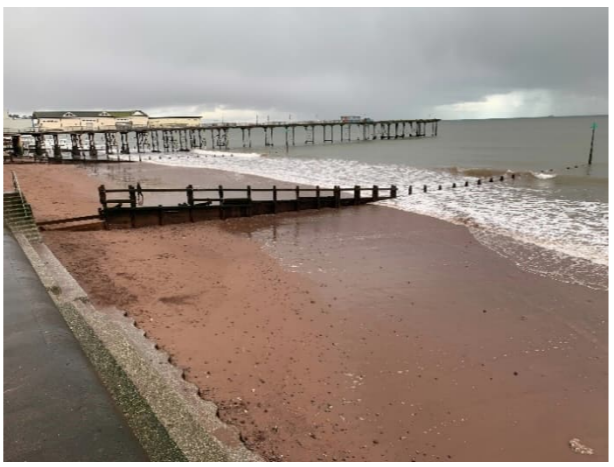
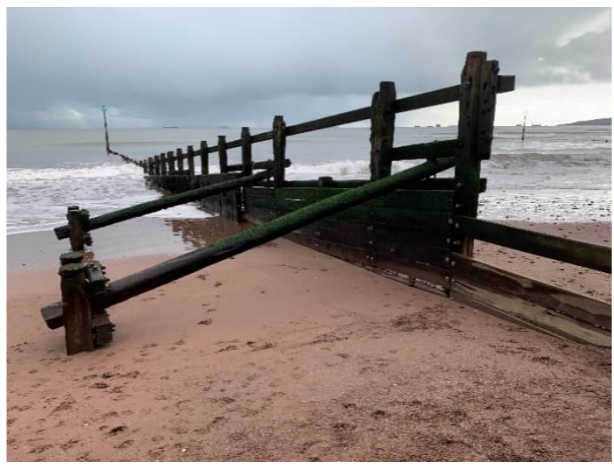



Appendix A. Condition Inspection by Asset

Teignmouth Beach Management Plan - Defences Baseline Report



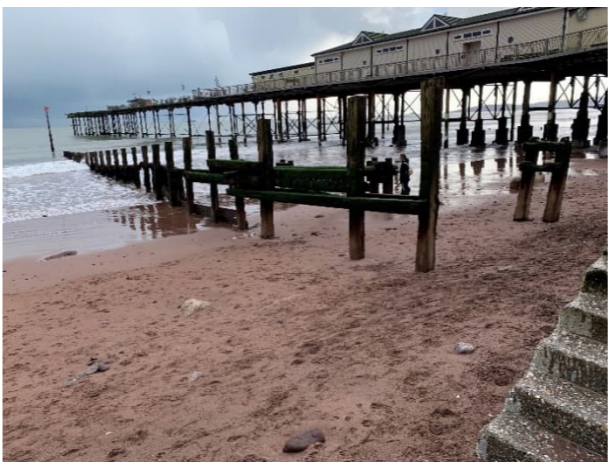

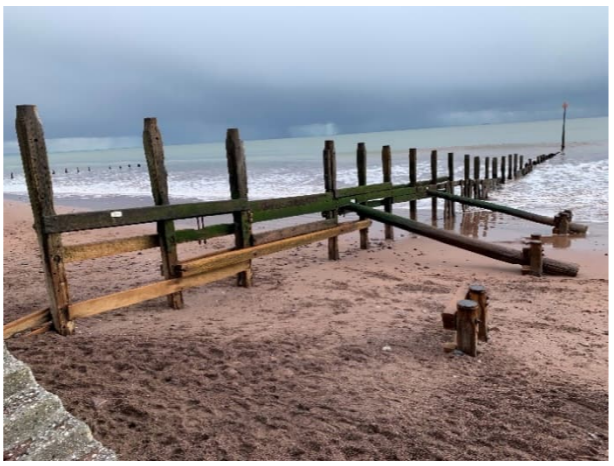
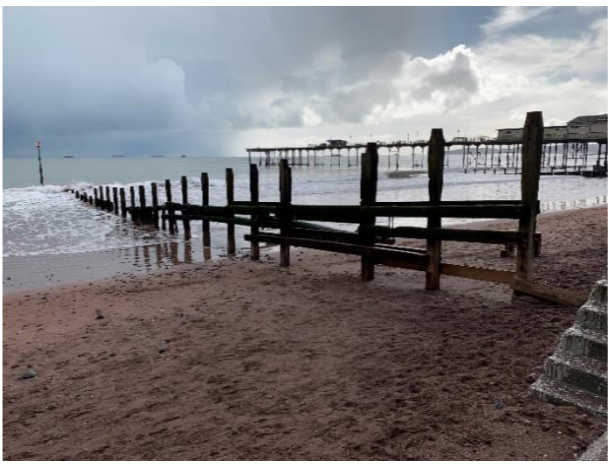
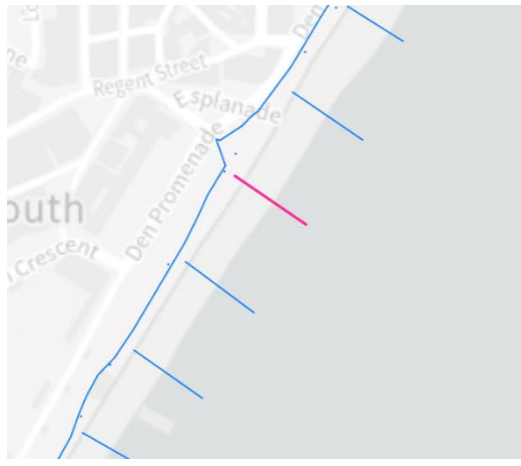

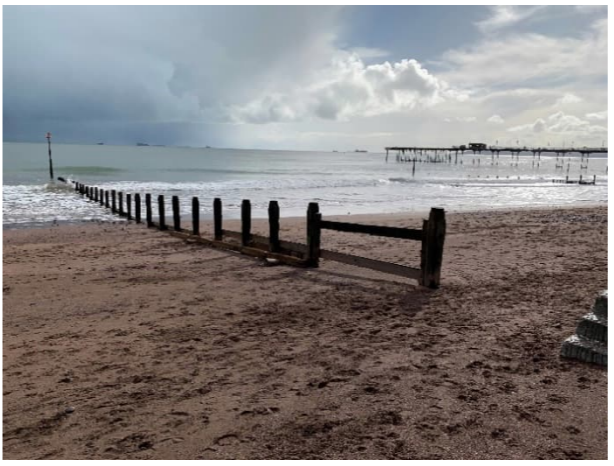

AIMS ID	Asset Name	Asset Length	Location Plan	Photos	Condition Description	Condition Grade	Exposure Rate	Residual Life (yrs) Maintenance: Medium / Low (due to beach lowering)	
TEIGNMOUTH OPEN COAST (West to East)									
n/a	The Point River Training Wall	85m				Cracks in concrete and abrasion. Undermining of facing concrete and exposure of stainless reinforcement at the seaward end.	3: Fair	Fastest	20 / 15
57776	Masonry Wall	245m				Masonry blocks and mortar joints good, minor differential movement in concrete slab at top of steps. Loss of majority of joint sealant to concrete slab and pile capping beam. Loss of majority of painted coating and some surface corrosion to piles.	2: Good	Fastest	30 (28) / 25
177697	Concrete Wall	526m				Sheet piled toe exposed at western end. Loss of majority of joint sealant along length. Small gap opening at top of precast step unit at west end. Abrasion of lower part of concrete wall, stepped toe and groyne access steps. Some cracks in concrete wall and some spalling of concrete at movement joints.	2: Good	Fastest	30 / 25 (5 - 11)

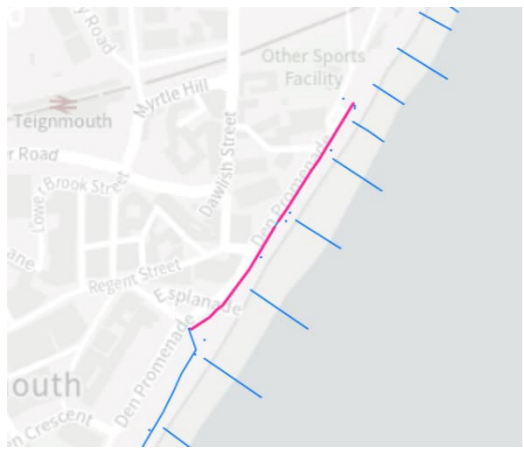

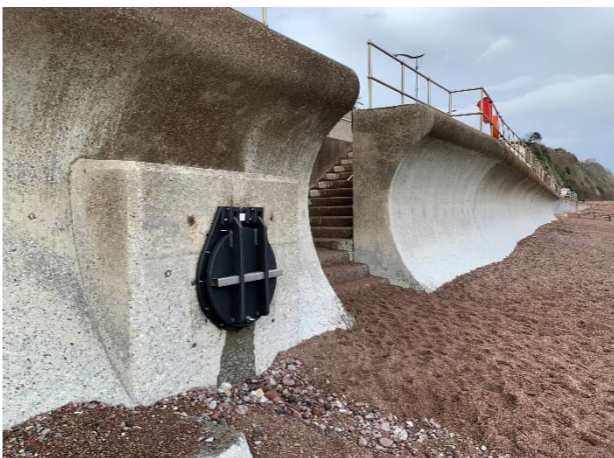



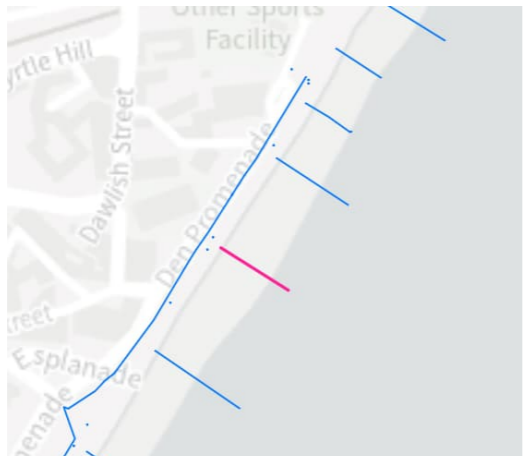
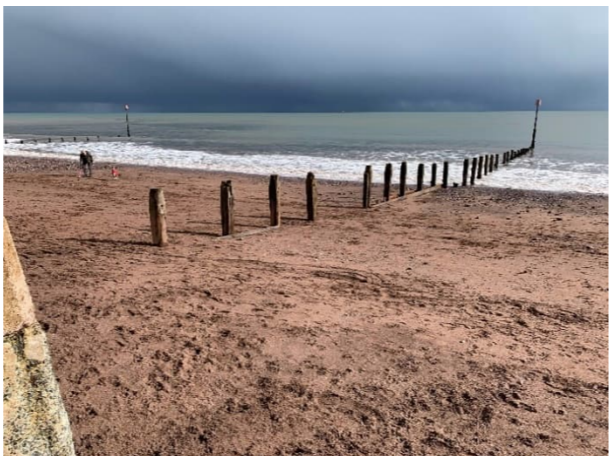

AIMS ID	Asset Name	Asset Length	Location Plan	Photos		Condition Description	Condition Grade	Exposure Rate	Residual Life (yrs) Maintenance: Medium / Low (due to beach lowering)
327119	Groyne 14	-				Groyne largely submerged at low tide so not possible to fully inspect. Piles still vertical, all planks missing across upper beach, significant number of planks missing across lower beach. Large gaps between planks, no longer retaining beach material. Navigation marker good.	4: Poor	Fastest	2 / 2
327118	Groyne 13	-				Piles vertical, little to no rotational movement. Some missing or damaged planks. Some gaps between planks. Timber abraded. Some new fixings. Groyne not retaining beach material.	4: Poor	Fastest	2 / 2
327117	Groyne 12	-				Piles vertical, no rotational movement. Many planks missing across upper beach. Abrasion to piles and planks abraded, large gaps between planks. Groyne not retaining beach material.	4: Poor	Fastest	2 / 2





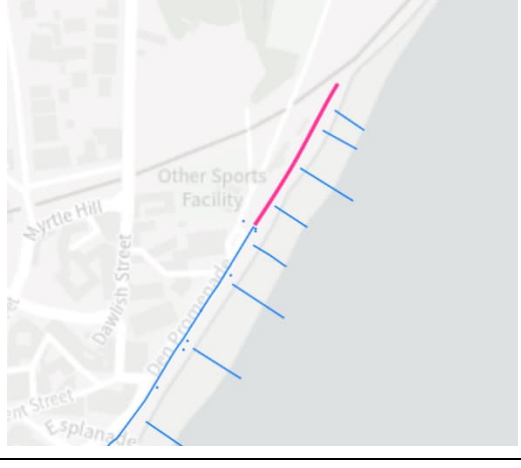
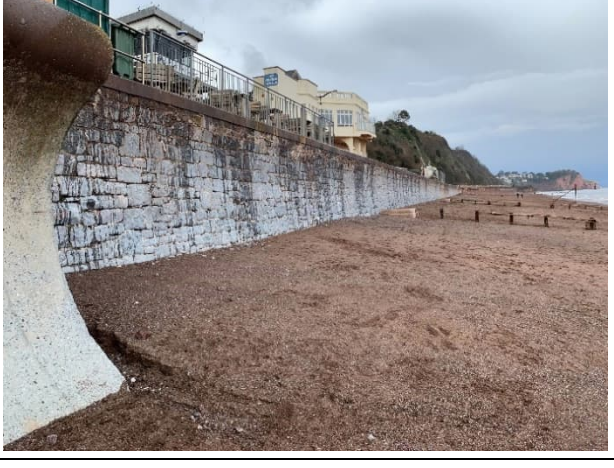

Teignmouth Beach Management Plan - Defences Baseline Report

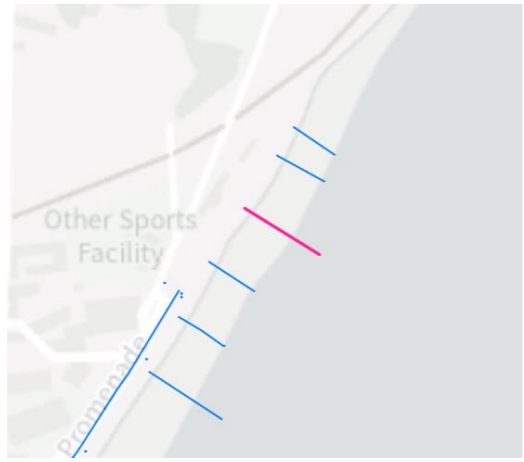

AIMS ID	Asset Name	Asset Length	Location Plan	Photos		Condition Description	Condition Grade	Exposure Rate	Residual Life (yrs) Maintenance: Medium / Low (due to beach lowering)
327116	Groyne 11	-				Piles vertical with no rotational movement. Some bracing support timbers missing. Majority of planks missing across upper beach. Abrasion to piles and plank. Fixings damaged or missing. Groyne not retaining beach material. Navigation marker ok.	4: Poor	Fastest	2 / 2
327115	Groyne 10	-				Piles vertical with no rotational movement. One bracing support timber missing. Majority of planks missing across upper and mid beach. Significant abrasion of piles and plank. Large gaps between planks where present. Corrosion of fixings. Groyne not retaining beach material. Navigation marker ok.	4: Poor	Fastest	2 / 2
327085	Groyne 9	-				Piles vertical with no rotational movement. Missing planks across upper beach. Some splitting of piles, significant abrasion to piles and planks. Large gaps between planks where present. Fixings damaged or missing. Groyne not retaining beach material. Navigation marker ok.	4: Poor	Fastest	2 / 2

Teignmouth Beach Management Plan - Defences Baseline Report

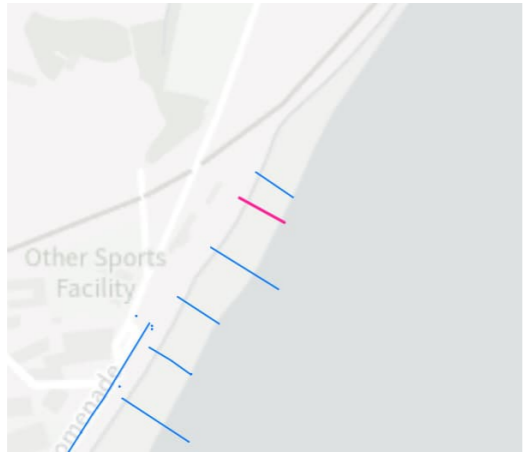



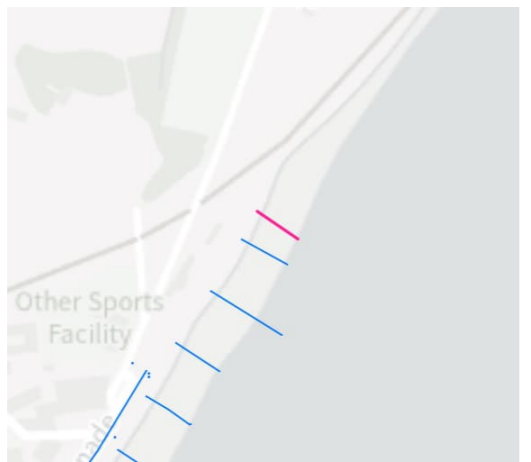
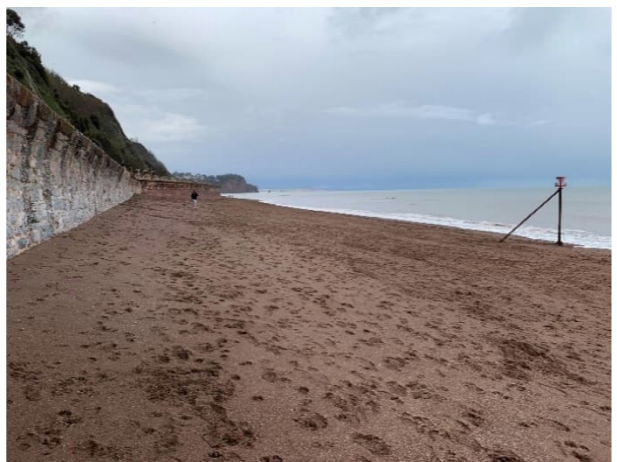

AIMS ID	Asset Name	Asset Length	Location Plan	Photos		Condition Description	Condition Grade	Exposure Rate	Residual Life (yrs) Maintenance: Medium / Low (due to beach lowering)
177501	Concrete Wall	252m				Masonry facing mostly good, some abrasion of mortar from joints. loss of mortar from joints. Loss of masonry along small section at east end by ramp. Sealant lost from many movement joints. High beach levels, toe steps not visible. Some cracks in upper concrete wall section. Navigation marker ok.	2: Good	Fastest	30 / 25
327084	Groyne 8	-				Piles vertical with no rotational movement. Significant abrasion and some splitting to piles. Planks missing or buried across upper and mid beach. Large gaps between planks where present. Groyne not retaining beach material. Navigation marker ok.	4: Poor	Fastest	2 / 2
327083	Groyne 7	-				Groyne largely buried. Significant abrasion and splitting to piles, some piles broken/missing. Planks buried or missing along majority of groyne. Fixings damaged or missing. Groyne not retaining beach material. Navigation marker ok.	4: Poor	Fastest	2 / 2



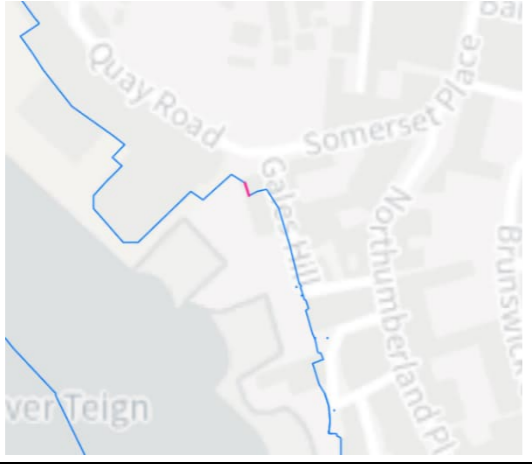

AIMS ID	Asset Name	Asset Length	Location Plan	Photos		Condition Description	Condition Grade	Exposure Rate	Residual Life (yrs) Maintenance: Medium / Low (due to beach lowering)
327082	Groyne 6	-				Piles vertical with no rotational movement. Significant abrasion and splitting of the piles, some piles missing. Planks missing or buried along majority of groyne. Groyne not retaining beach material. Navigation marker ok.	4: Poor	Fastest	2 / 2
497233	Groyne 5	-				Groyne largely buried. Planks missing. Groyne not retaining beach material. Navigation marker ok.	4: Poor	Fastest	2 / 2
n/a	Masonry Wall	160m				Masonry and mortar in ok condition, some abrasion of mortar but no gaps. Section of wall replaced by concrete, some horizontal gaps in construction joints. High beach levels over toe.	3: Fair	Fastest	20 / 15

AIMS ID	Asset Name	Asset Length	Location Plan	Photos		Condition Description	Condition Grade	Exposure Rate	Residual Life (yrs) Maintenance: Medium / Low (due to beach lowering)
327081	Groyne 4	-				Groyne largely buried. Metal piles visible. Many planks missing, significant abrasion to planks that remain. Majority of fixings corroded. Groyne not retaining beach material. No navigation marker.	4: Poor	Fastest	2 / 2
327080	Groyne 3	-				Groyne largely buried. Majority of planks missing, abrasion and large gaps between planks that remain. Groyne not retaining beach material. Navigation marker ok.	4: Poor	Fastest	2 / 2
327079	Groyne 2	-			Completely buried at time of inspection. Historic photos from May 2018 included for reference (reference Google Street View).	Groyne completely buried. No navigation marker. Historic photos May-18 show missing planks missing, abrasion and large gaps between planks.	4: Poor	Fastest	2 / 2

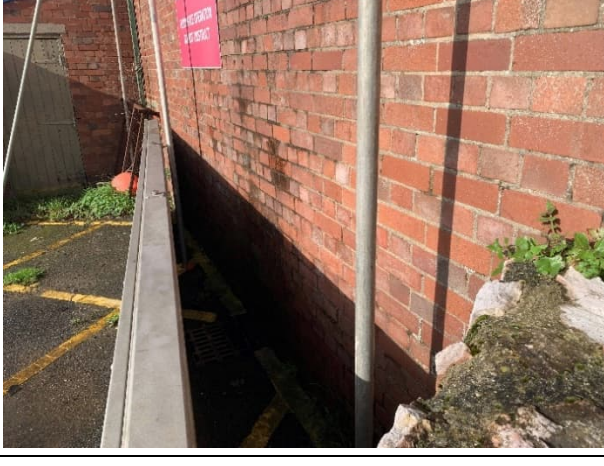
AIMS ID	Asset Name	Asset Length	Location Plan	Photos		Condition Description	Condition Grade	Exposure Rate	Residual Life (yrs) Maintenance: Medium / Low (due to beach lowering)
327078	Groyne 1 SWW Outfall	-				Groyne completed buried except for gridded outlet to pipe. Navigation marker ok.	-	Fastest	-

Teignmouth Beach Management Plan - Defences Baseline Report

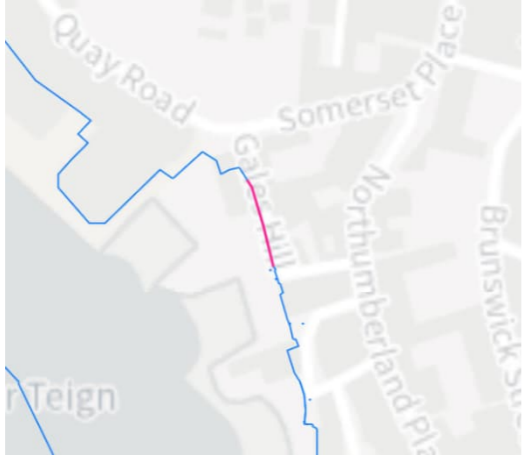



AIMS Asset ID	Asset Name	Asset Length	Location Plan	Photos	Condition Description	Condition Grade	Exposure Rate	Residual Life (yrs) Maintenance: Medium / Low (due to beach lowering)
TEIGNMOUTH BACK BEACH (North to South)								
392714	Floodgate 7 - Gales Hill Ramp	8.0m		 	Gate, hinges and sealing faces in good condition. Timber facing ok. Gate and frame alignment appears ok. Gates not operated during inspection.	2: Good	Slowest	22 / 17
392717	Pumping Station Wall	7.1m		 	Some spalling of bricks and loss of mortar. Some vegetation growth.	2: Good	Slowest	80 / 65
392716	Masonry Wall	10.3m			Bricks and joints in good condition.	2: Good	Slowest	80 / 65





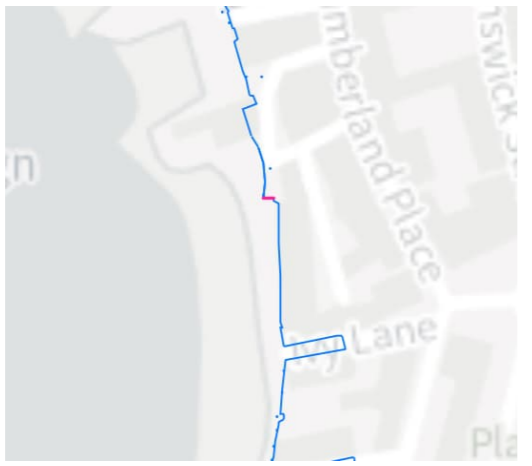

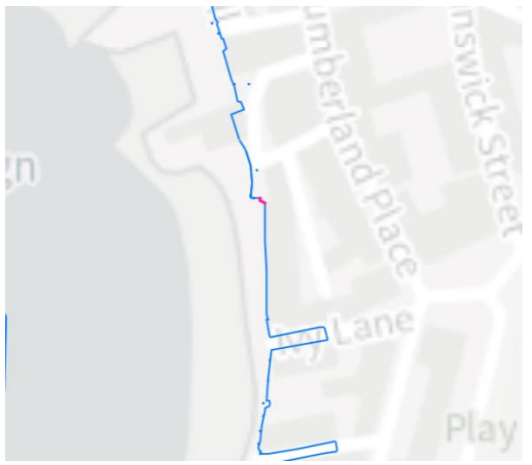
AIMS Asset ID	Asset Name	Asset Length	Location Plan	Photos	Condition Description	Condition Grade	Exposure Rate	Residual Life (yrs) Maintenance: Medium / Low (due to beach lowering)
392718	Back Beach Ramp	7.9m			Gate, hinges and sealing faces in good condition. Gate and frame alignment appear ok. Gates not operated during inspection.	2: Good	Slowest	22 / 17
180688	Masonry Wall	43.7m			Mortar in good condition. No undermining. Some debris either side of the ramp along the wall.	2: Good	Slowest	80 / 65
392732	Floodgate Osmond Lane Ramp	2.6m			Gate, hinges and sealing faces in good condition. Gate and frame alignment appear ok. Gates not operated during inspection.	2: Good	Slowest	22 / 17



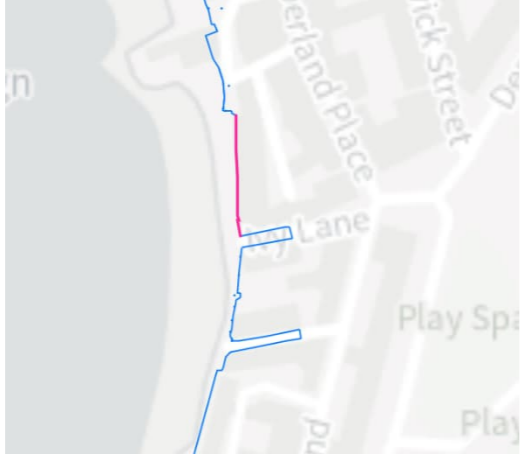

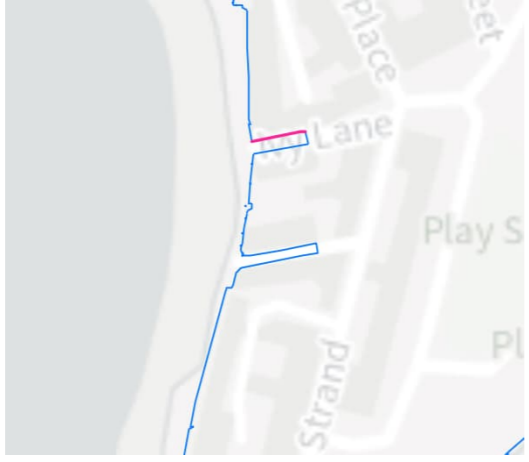

AIMS Asset ID	Asset Name	Asset Length	Location Plan	Photos	Condition Description	Condition Grade	Exposure Rate	Residual Life (yrs) Maintenance: Medium / Low (due to beach lowering)
392733	Masonry Wall	8.1m			Mortar in good condition. No undermining. Some debris either side of the ramp along the wall.	2: Good	Slowest	80 / 65
392734	Masonry Property Wall	23.2m			Wall of pub, scaffolding up at time of inspection. Wall in good condition. No flood proof windows. Section of masonry wall with a glass window, masonry in good condition, window seals ok, some rust in frame.	2: Good	Slowest	80 / 65
392735	Floodgate New Quay (North)	6.4m			Gate and hinges ok, minor cracking to seals. Some rot along lower edge of timber facing boards. Some sediment around hinge. Gates not operated during inspection.	2: Good	Slowest	22 / 17



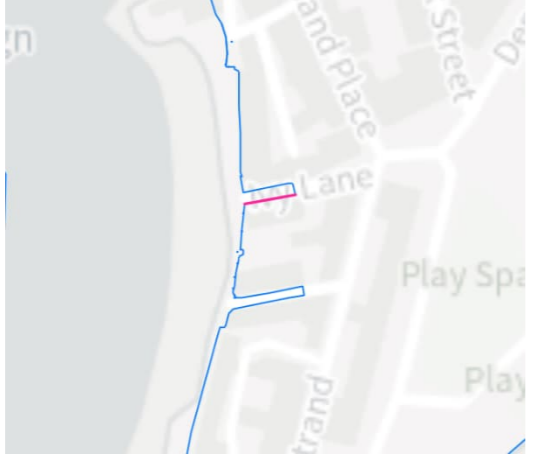

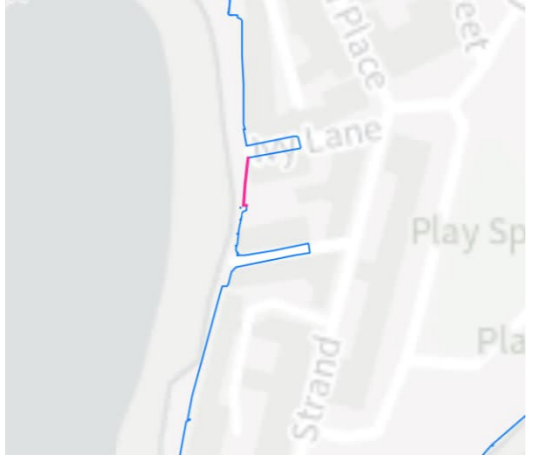

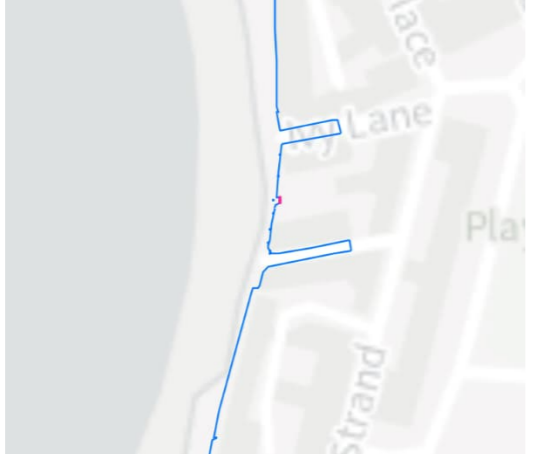
Teignmouth Beach Management Plan - Defences Baseline Report

AIMS Asset ID	Asset Name	Asset Length	Location Plan	Photos	Condition Description	Condition Grade	Exposure Rate	Residual Life (yrs) Maintenance: Medium / Low (due to beach lowering)
4142	Masonry Property Wall	23.4m			Visible elements of wall in reasonable condition, no loss of mortar. Walls within building not inspected.	3: Fair	Slowest	40 / 35
392752	Floodgate New Quay (South)	4.8m			Gate and hinges ok, minor cracking to seals. Some rot along lower edge of timber facing boards. Some sediment around hinge. Gates not operated during inspection.	2: Good	Slowest	22 / 17
10148	Masonry Wall	21.4m			Masonry, mortar joints and coping in good condition. No cracks or movement. High beach levels along toe. Minimal algae growth.	2: Good	Slowest	80 / 65

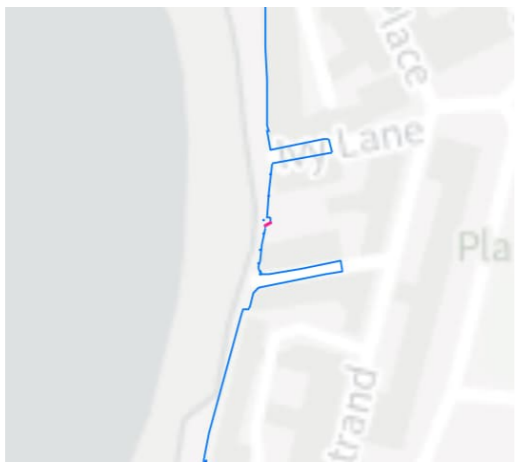
AIMS Asset ID	Asset Name	Asset Length	Location Plan	Photos	Condition Description	Condition Grade	Exposure Rate	Residual Life (yrs) Maintenance: Medium / Low (due to beach lowering)
524451	TDS Back Beach	21.4m		[Demountable defences not installed at time of inspection]	Demountable defence on top of seawall 10148. End plates and sockets in good condition, some vegetation growth. No seals visible, assume to be integral to boards. Boards (assumed metal) not available for inspection.	2: Good	Slowest	60 / 20
392754	Floodgate 12 - Back Beach Access Ramp	3.9m			Gate and hinges in good condition. Some cracks and splitting of seals. Gate and frame alignment ok. Some rot to facing timbers. Debris on beach side of gate. No damage visible. Gate not operated during inspection.	2: Good	Slowest	22 / 17
180673	Masonry Wall with Glazing	3.8m			Masonry and mortar joints ok. No cracks or settlement. Large amounts of algae growth. Window and seal ok. Timber lintel in poor condition.	2: Good	Slowest	80 / 65

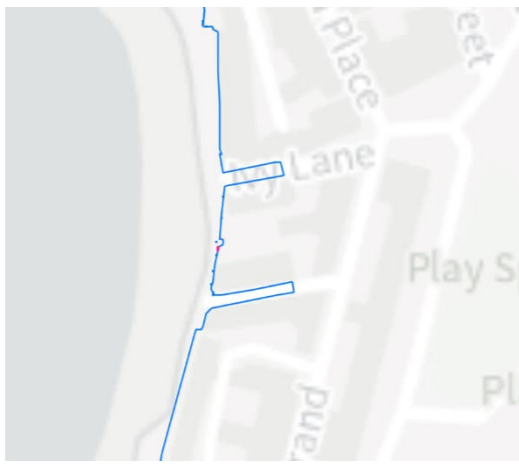

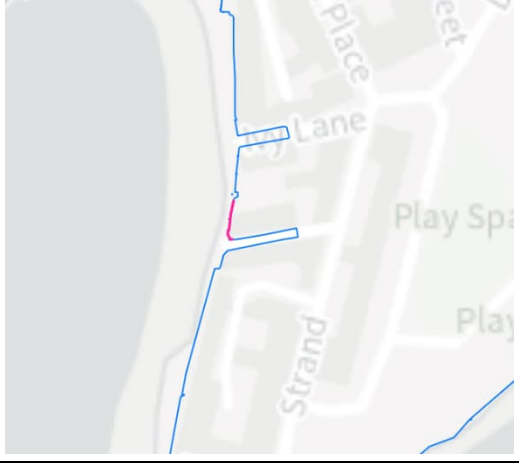

AIMS Asset ID	Asset Name	Asset Length	Location Plan	Photos	Condition Description	Condition Grade	Exposure Rate	Residual Life (yrs) Maintenance: Medium / Low (due to beach lowering)
42304	Rendered Property Walls	60.5m			No cracks in render or signs of movement or settlement. Floodproof windows and doors appear ok. Evidence of one door having been replaced. High beach levels, wide crest.	3: Fair	Slowest	40 / 35
180630	Ivy Lane - north wall	24.6m			No cracks in render or signs of movement or settlement. Floodproof windows and doors appear ok.	3: Fair	Slowest	40 / 35
392783	Engineered High Ground	6.1m			-	-	Slowest	-





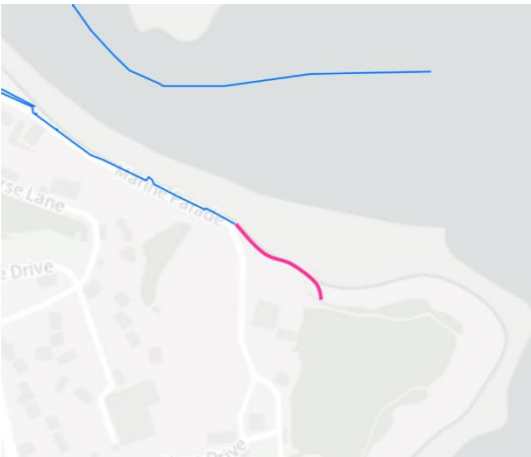

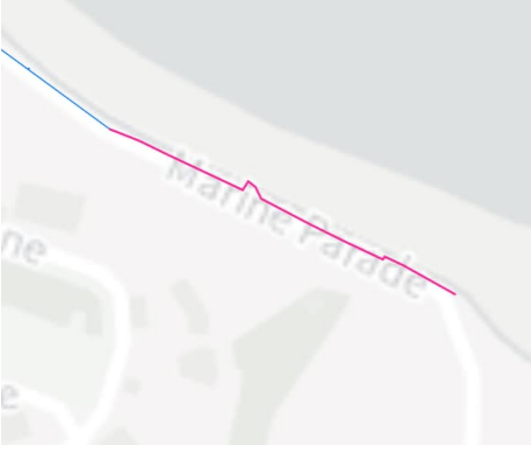
AIMS Asset ID	Asset Name	Asset Length	Location Plan	Photos	Condition Description	Condition Grade	Exposure Rate	Residual Life (yrs) Maintenance: Medium / Low (due to beach lowering)
3935	Masonry Property Wall	24.9m			Masonry blocks and mortar joints ok. No cracks or signs of movement or settlement. No flood proof doors at openings.	3: Fair	Slowest	40 / 35
392776	Masonry Property Wall	24.0m			Stone blocks and mortar ok, no cracks. Two sections of missing coping. Flap valve in good condition. Minor erosion and undermining of concrete toe. No access to landward side.	2: Good	Slowest	80 / 65
392774	Floodgate Coastguard Station	2.8m			Gate and frame ok, timber facing boards in fair condition. Minor corrosion to frame. Seals not visible as gate closed. Hinges not accessible as no access to landward side. Gate not operated at time of inspection.	2: Good	Slowest	22 / 17



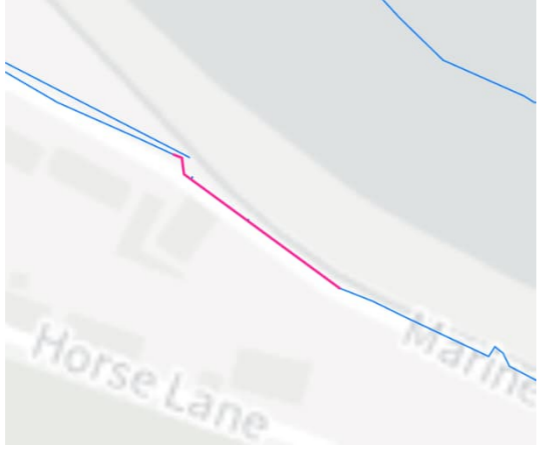

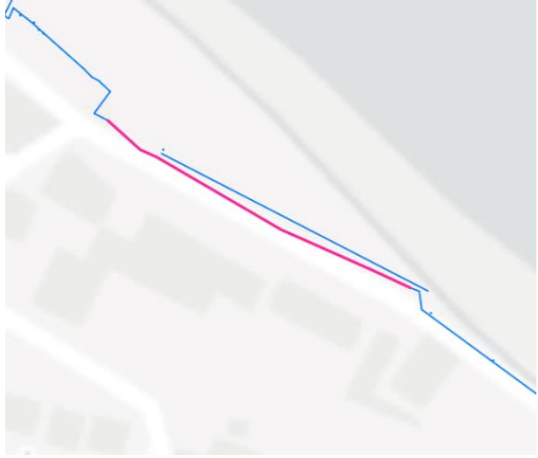

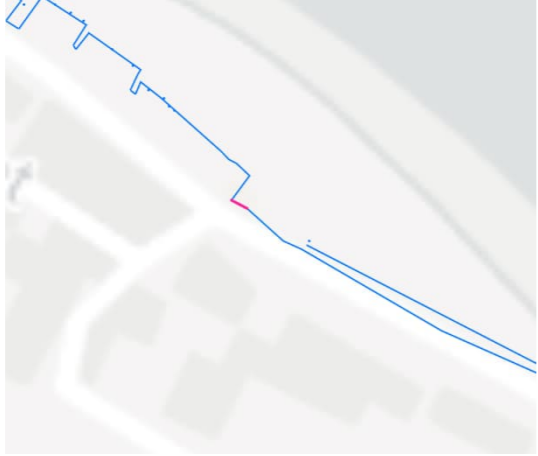
AIMS Asset ID	Asset Name	Asset Length	Location Plan	Photos	Condition Description	Condition Grade	Exposure Rate	Residual Life (yrs) Maintenance: Medium / Low (due to beach lowering)
392777	Masonry Property Wall	2.6m			Masonry blocks and mortar joints ok, no cracks. No access to landward side.	2: Good	Slowest	80 / 65
392778	Floodgate 6 Marine Terrace	1.1m			Gate and frame ok, timber facing boards in fair condition. Minor corrosion to frame. Seals and hinges not visible as gate closed. Gate not operated at time of inspection. No access to landward side.	2: Good	Slowest	22 / 17
392779	Masonry Property Wall	20.6m			Masonry blocks and mortar joints in good condition, no cracks. Minor undermining to concrete apron at toe. Flap valves in good condition.	2: Good	Slowest	80 / 65

AIMS Asset ID	Asset Name	Asset Length	Location Plan	Photos	Condition Description	Condition Grade	Exposure Rate	Residual Life (yrs) Maintenance: Medium / Low (due to beach lowering)
392780	Masonry Property Wall	32.1m			Masonry blocks and mortar joints ok. No flood proof doors in openings.	2: Good	Slowest	80 / 65
392782	Engineered High Ground	4.7m			-	-	Slowest	-
181119	Rendered Property Wall	35.5m			Render ok, no cracks. Unclear if doors are flood proof.	2: Good	Slowest	80 / 65

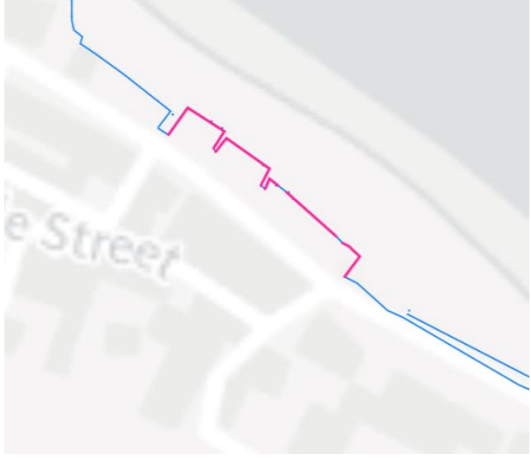

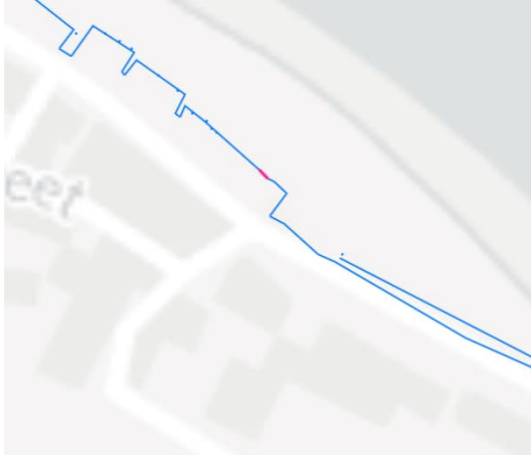

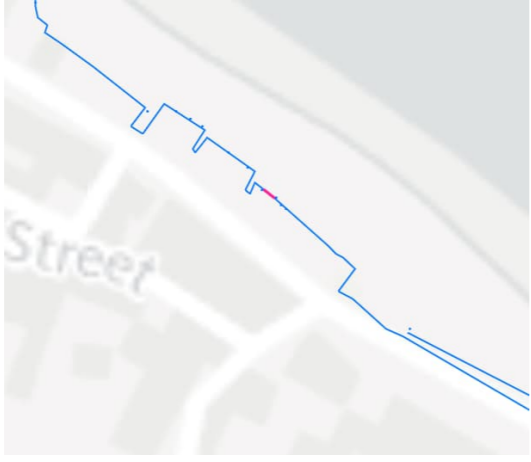

AIMS Asset ID	Asset Name	Asset Length	Location Plan	Photos	Condition Description	Condition Grade	Exposure Rate	Residual Life (yrs) Maintenance: Medium / Low (due to beach lowering)
392781	Masonry Wall with Glazing	14.4m			Masonry and mortar joints good. Significant calcium deposits on concrete toe. Glazing and seals good, wooden lintels in good condition. Concrete apron ok.	2: Good	Slowest	80 / 65
3934	Concrete	152.2m			Minor cracks and spalling of render. Some undermining of wall on beach at northern end.	3: Fair	Medium	30 / 20



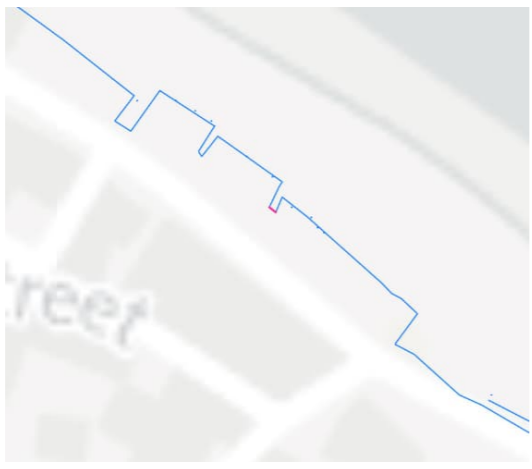



AIMS Asset ID	Asset Name	Asset Length	Location Plan	Photos	Condition Description	Condition Grade	Exposure Rate	Residual Life (yrs) Maintenance: Medium / Low (due to beach lowering)
SHALDON								
n/a	Concrete Wall	100m		 	General cracks and spalling to concrete, missing flap valves, abrasion to concrete toe and steps, corrosion of reinforcement in sprayed concrete facing, erosion to earth bank at crest, some undermining of toe at northern end. Escape ladder in good condition.	3:Fair	Medium	30 / 20
84539	Masonry Wall	151.8m		 	No gaps in masonry joints. Mortar good. Concrete repairs to masonry sound. Some abrasion to concrete toe, occasional cracks. Initial undermining of concrete toe in places, contractor on site filling voids with concrete.	2: Good	Medium	55 / 40

AIMS Asset ID	Asset Name	Asset Length	Location Plan	Photos	Condition Description	Condition Grade	Exposure Rate	Residual Life (yrs) Maintenance: Medium / Low (due to beach lowering)
84538	Masonry Wall	74.1m		 	No gaps in masonry. Expansion joints good. Some masonry, in good condition. Minor erosion of lower wall and toes.	3: Fair	Medium	30 / 20
84537	Masonry Wall	106.5m		 	No gaps in masonry. Expansion joints good. No cracks in promenade surfacing. Generally high beach levels. Localised undermining of toe at southern end.	2: Good	Medium	55 / 40
332938	Ferry Boat Shelter flood gate 10	5.6m		 	Gate, hinges and sealing faces in good condition. Gate and frame alignment appear ok. Seals protected by metal covers. Gates not operated during inspection.	2: Good	Slowest	22 / 17

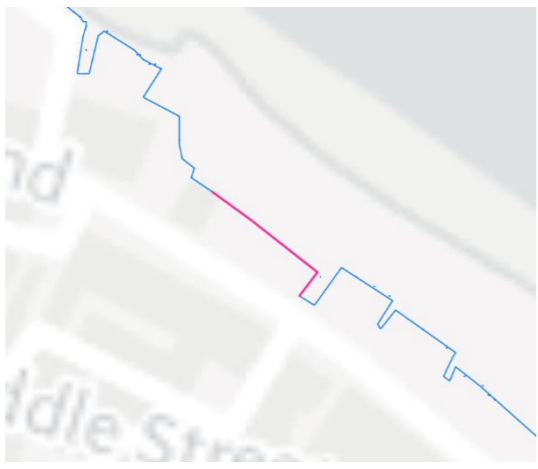
AIMS Asset ID	Asset Name	Asset Length	Location Plan	Photos	Condition Description	Condition Grade	Exposure Rate	Residual Life (yrs) Maintenance: Medium / Low (due to beach lowering)
84540	Masonry Wall	104.0m			No gaps in masonry. Minor abrasion at the base of the historic wall. Mortar in good condition, some separation between mortar and masonry. Joints in good condition.	2: Good	Slowest	80 / 65
332936	Beach Comber flood boards	3.4m			Channels appear straight. No signs of damage. Minor corrosion and degradation of protective coating, no boards present at time of inspection. Boards assumed to be metal due to narrow channels.	3: Fair	Slowest	50 / 15
332937	Ferry Boat Pub flood boards	3.3m			Channels appear straight. No signs of damage. Minor corrosion and degradation of protective coating, no boards present at time of inspection. Boards assumed to be metal due to narrow channels.	3: Fair	Slowest	50 / 15

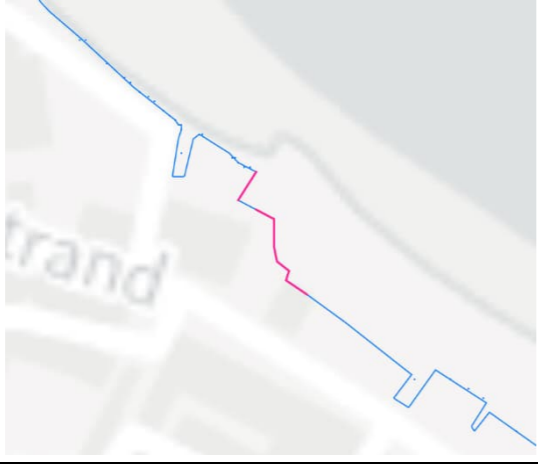
Teignmouth Beach Management Plan - Defences Baseline Report

AIMS Asset ID	Asset Name	Asset Length	Location Plan	Photos	Condition Description	Condition Grade	Exposure Rate	Residual Life (yrs) Maintenance: Medium / Low (due to beach lowering)
332935	Ferry Boat Alleyway flood gate 9	1.5m			Gate, hinges and sealing faces in good condition. Gate and frame alignment appear ok. Seals protected by metal covers. Gate not operated during inspection.	2: Good	Slowest	22 / 17
332934	Tom Thumb Alleyway flood gate 8	1.5m			Gate, hinges and sealing faces in good condition. Gate and frame alignment appear ok. Seals protected by metal covers. Gate not operated during inspection.	2: Good	Slowest	22 / 17
332933	Manor Alleyway Slipway flood gate 7	4.4m			Gate, hinges and sealing faces in good condition. Gate and frame alignment appear ok. Seals protected by metal covers. Gate not operated during inspection.	2: Good	Slowest	22 / 17

AIMS Asset ID	Asset Name	Asset Length	Location Plan	Photos	Condition Description	Condition Grade	Exposure Rate	Residual Life (yrs) Maintenance: Medium / Low (due to beach lowering)
82711	Masonry Wall	37.8m			Minor abrasion to lower stone and mortar. Joints in good condition.	2: Good	Slowest	80 / 65
82710	Masonry Wall	35m			Minor undermining at building. Masonry and mortar in good condition. Some abrasion over lower half of the wall. Access ladders in good condition. Flap valves in good condition.	2: Good	Slowest	80 / 65
332932	Shaldon Quay flood gate 6	4.8m			Gate, hinges and sealing faces in good condition. Gate and frame alignment appears ok. Seals protected by metal covers. Gates not operated during inspection.	2: Good	Slowest	22 / 17

Appendix B. Overtopping Assessment

Teignmouth Overtopping Assessment

Date: 17 May 2024
Project name: Teignmouth Beach Management Plan
Project no: B2471100
Company: Environment Agency
Prepared by: Emily Marshall
Reviewed by: Matthew Stannard
Document no: Overtopping Assessment
Revision no: P02 (28-Jan-25, minor changes)

Jacobs UK
The West Wing
1 Glass Wharf
Bristol, BS2 0EL
United Kingdom
T +44 (0)117 457 2500

Contents

Acronyms and abbreviations.....	ii
1. Introduction.....	1
1.1 The Purpose of the Report.....	1
1.2 Background and Study Area	1
2. Analysis Inputs.....	2
2.1 Methodology.....	2
2.2 Cross Section Dimensions.....	3
2.2.1 TEI_01 and 6b00191	3
2.2.2 TEI_08 and 6b00204	4
2.3 Wave conditions.....	5
3. Overtopping.....	7
3.1 Results from previous reports	7
3.2 Standard of Protection (SoP)	7
3.2.1 Overtopping Limits.....	7
3.2.2 Resulting Standard of Protection	8
4. Conclusions.....	11
5. References	12

Tables

Table 2-1: Cross section dimensions for each profile line	3
Table 2-2: Wave Conditions used in JBA (2021) and BMP (2014)	6
Table 3-1: Overtopping results from both JBA (2021) and BMP (2014) for a 1 in 200-year Return Period	7
Table 3-2: Standard of protection at Teignmouth based on BMP (2014) overtopping rates and EurOtop (2007) and EurOtop II (2018) tolerable limits.....	9
Table 3-3: Standard of protection at Shaldon based on JBA (2021) overtopping rates and EurOtop II (2018) tolerable limits.	9

Figures

Figure 1-1: Extent of the Defence assessment for Teignmouth and Shaldon	1
Figure 2-1: Profiles from JBA (2021) and BMP (2014)- Shaldon to the Pier at Teignmouth.....	2
Figure 2-2: Profiles from JBA (2021) and BMP (2014)- From the Pier at Teignmouth to the Railway	2
Figure 2-3: SWRCMP data (2022) for Profile 6b00191 with crest levels used in the BMP and JBA overtopping analyses highlighted.	4
Figure 2-4: Photos from a recent site walkover at the rough location of the profile 6b00191 with crest levels used in the BMP and JBA overtopping analyses highlighted light blue and dark blue respectively.	4
Figure 2-5: SWRCMP data (2022) for Profile 6b00204 with crest levels used in the BMP and JBA overtopping analyses highlighted.	5
Figure 2-6: Photos from a recent site walkover at the rough location of the profile 6b00204 with crest levels used in the BMP and JBA overtopping analyses highlighted light blue and dark blue respectively.	5
Figure 3-1: Extract from EurOtop (2007) indicating tolerable overtopping discharges for structural damage..	8
Figure 3-2: Extract from EurOtop (2018) indicating tolerable overtopping discharges for public safety.	8

Acronyms and abbreviations

BMP	Beach Management Plan
RP	Return Period
SWRCMP	Southwest Regional Coastal Monitoring Programme

1. Introduction

1.1 The Purpose of the Report

This Technical Note summarises an assessment of the standard of protection of typical defence sections along the Teignmouth and Shaldon Frontage. The Teignmouth frontage extents are from Sprey Point to the Point. These results shall inform the Beach Management Plan for Teignmouth and Shaldon.

1.2 Background and Study Area

Teignmouth is located at the mouth of the river Teign, located on the South-East coast of Devon. The defences and beaches for this assessment have been examined along the town of Teignmouth and village of Shaldon, at the mouth of the Teign Estuary. The extent of the assessment is shown in Figure 1-1.

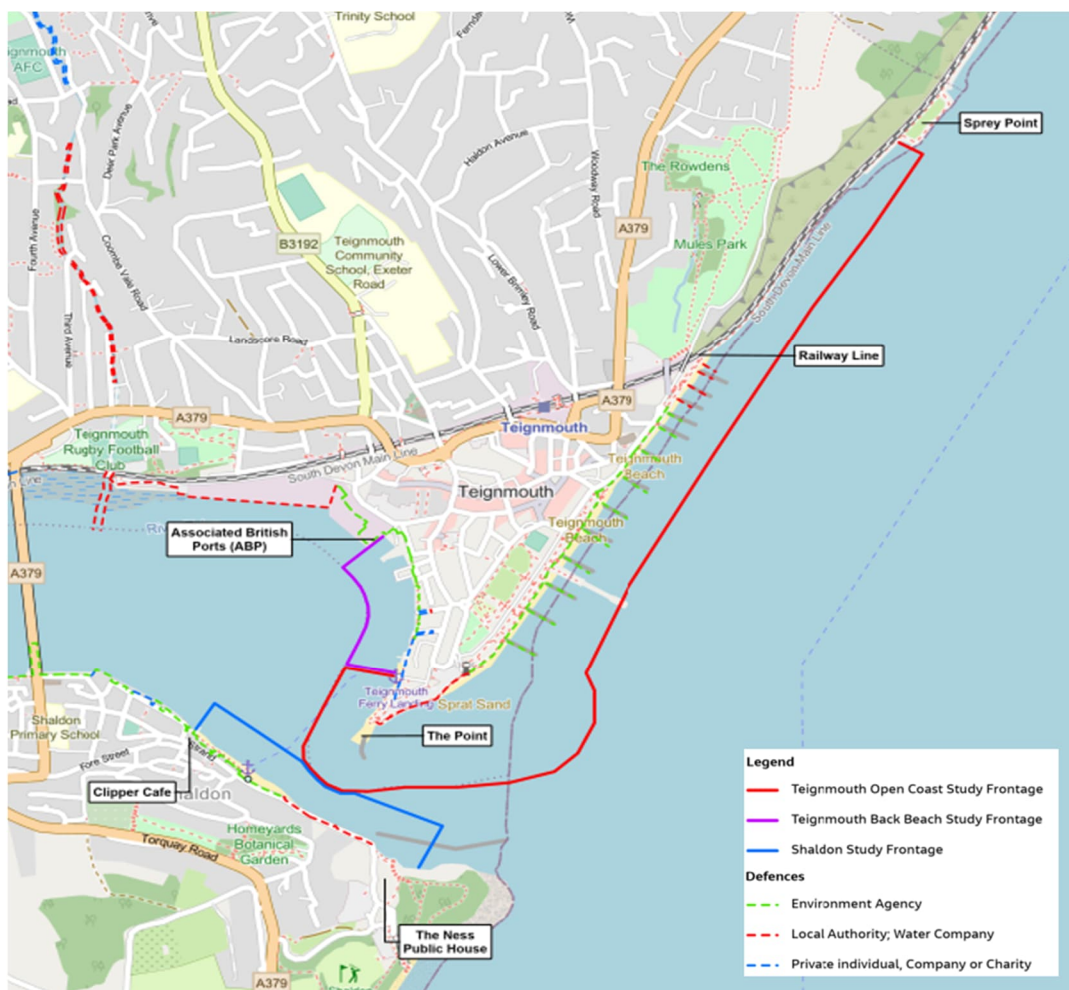

Figure 1-1: Extent of the defence assessment for Teignmouth and Shaldon

Based on a Jacobs (2024b) assessment of the economics, present value damage are estimated at £116.5 million and £3.1 million for Teignmouth and Shaldon respectively. .

Behind the immediate shoreline of Teignmouth and Shaldon the land is used for a mixture of residential and commercial properties, general amenity and shipping activities. As a result of the historic high value of tourism to both Teignmouth and Shaldon, there are also a number of amenity facilities along the shorelines including berthing facilities, restaurants, Teignmouth lido, a mini golf course and tennis/multi-purpose court. The shoreline also forms a part of the South West Coast Path.

2. Analysis Inputs

2.1 Methodology

Previously calculated overtopping rates from the 2014 Beach Management Plan (BMP) supplemented by results from the 2021 JBA modelling report have been used as a desk study to determine existing defence standard of protection.

The two reports consider different sets of profiles along the coast. The BMP uses beach profiles from the Southwest Regional Coastal Monitoring Programme (SWRCMP) while JBA have adopted other profiles these are combined in the plan as seen in Figure 2-1 and Figure 2-2.



Figure 2-1: Profiles from JBA (2021) and BMP (2014)- Shaldon to the pier at Teignmouth.

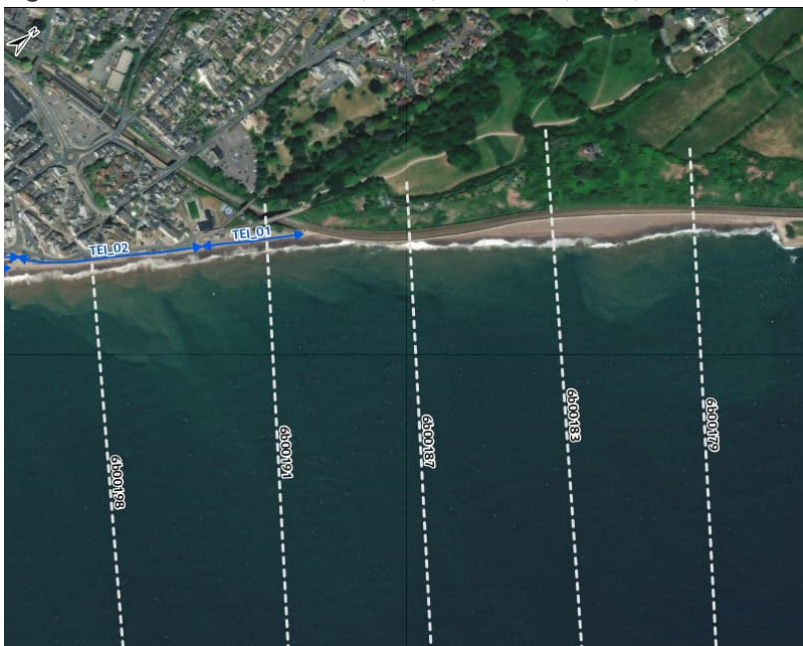

Figure 2-2: Profiles from JBA (2021) and BMP (2014)- From the pier at Teignmouth to the railway.

2.2 Cross Section Dimensions

Cross sections dimensions have been taken from the BMP (2014) and JBA (2021) reports and are summarised in Table 2-1.

Table 2-1: Cross section dimensions for each profile line

Section Name		Crest Level (mODN)		Toe Level (mODN)
JBA (2021)	BMP (2014)	JBA (2021)	BMP (2014)	JBA (2021)
TEI_01	6b00191	6.80	5.80	0.96
TEI_02	6b00198	7.00	6.80	1.43
TEI_03 ¹	6b00204	4.78	4.70	1.25
TEI_04	6b00216	5.23	5.20	0.37
TEI_05	SHALDON	4.28	-	2.08
TEI_06	SHALDON	4.85	-	2.26
TEI_07	6b00212	4.84	4.60	0.00
TEI_08 ¹	6b00204	5.90	4.70	1.25

¹ TEI_03 and TEI_08 are at the same longshore location. The difference is how far inland they extend. TEI_03 just goes over the seawall whereas TEI_08 goes up the prom and over the set-back wall. The BMP only calculated overtopping at this longshore location for the seawall.

Despite no major additional intervention occurring to the sea defence structures other than patch repairs in 2016 the crest level shows a variation from the BMP (2014) and the JBA model (2021).

Where the crest levels vary significantly, the use of recent (2022) SWRCMP data as well as images taken from site have been used to determine the likely cause of this. This is set out in the following sections.

2.2.1 TEI_01 and 6b00191

Recent profile data from the SWRCMP is presented in Figure 2-3. The crest levels used for the different overtopping analyses are highlighted.

In this case, it can be seen that the discrepancy in the crest level from the BMP (2014) and JBA report (2021) is due to the definition of where the overtopping is taking place. In the BMP (2014) overtopping is considered on the top of the sea wall, whereas on the JBA report (2021) overtopping is considered on the flood wall at the back of the promenade. The likely reason for the discrepancy is that the JBA modelling report (2021) considers overtopping for flood risk potential and as such the full defence height against flooding is considered. For the BMP (2014) overtopping is used as an indicator of structural integrity of the sea defence, hence, the sea wall crest level is considered.

For this assessment, overtopping shall also be used to assess standard of protection against structural failure. As such, results from the overtopping analysis for the BMP (2014) shall be considered.

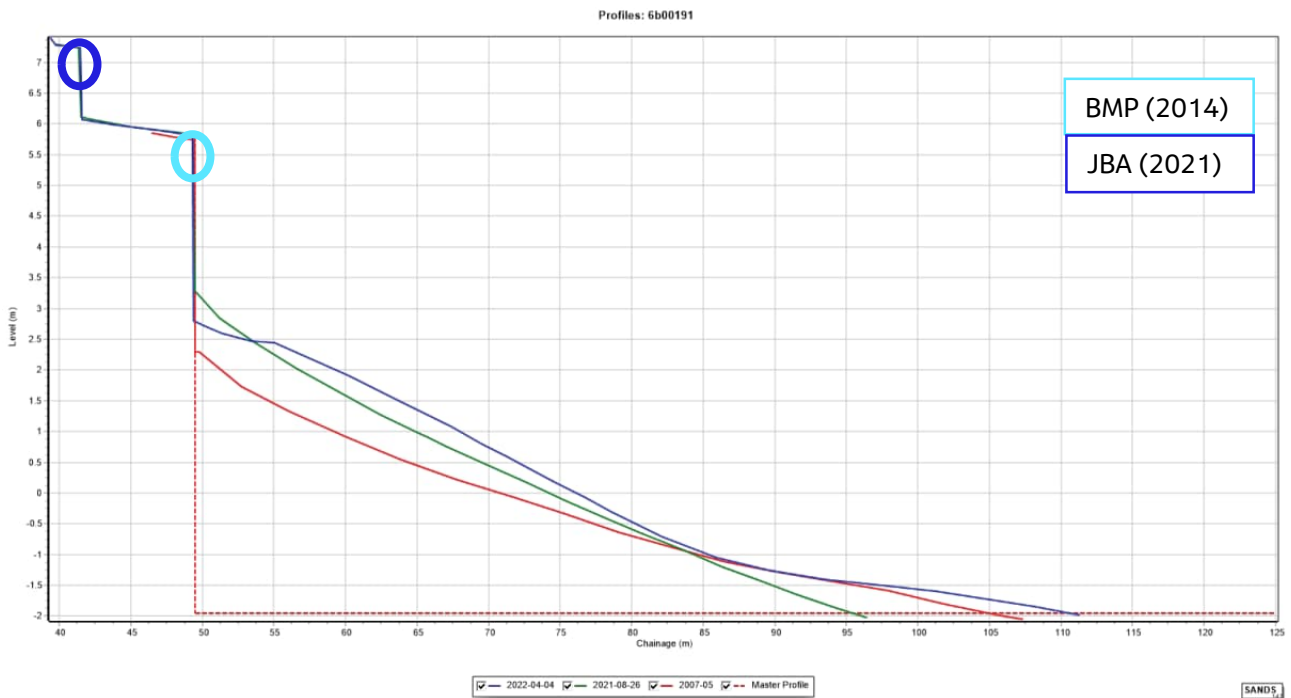

Figure 2-3: SWRCMP data (2022) for Profile 6b00191 with crest levels used in the BMP and JBA overtopping analyses highlighted.

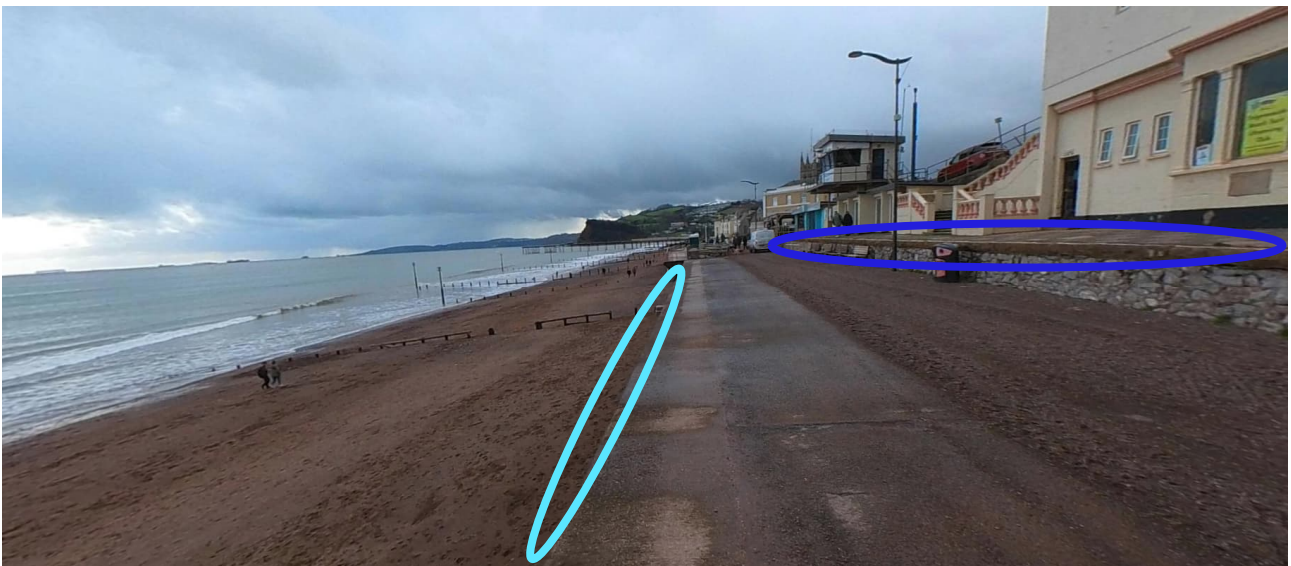

Figure 2-4: Photos from a recent site walkover at the rough location of the profile 6b00191 with crest levels used in the BMP and JBA overtopping analyses highlighted light blue and dark blue respectively.

2.2.2 TEI_08 and 6b00204

Recent profile data from the SWRCMP is presented in Figure 2-5. The crest levels used for the different overtopping analyses are highlighted.

In this case, it can be seen that the discrepancy in the crest level from the BMP (2014) and JBA report (2021) is due to the definition of where the overtopping is taking place. In the BMP (2014) overtopping is considered on the top of the sea wall, whereas on the JBA report (2021) overtopping is considered on the flood wall at

the back of the promenade. The likely reason for the discrepancy is that the JBA modelling report (2021) considers overtopping for flood risk potential and as such the full defence height against flooding is considered. For the BMP (2014) overtopping is used as an indicator of structural integrity of the sea defence, hence, the sea wall crest level is considered.

For this assessment, overtopping shall also be used to assess standard of protection against structural failure. As such, results from the overtopping analysis for the BMP (2014) shall be considered.

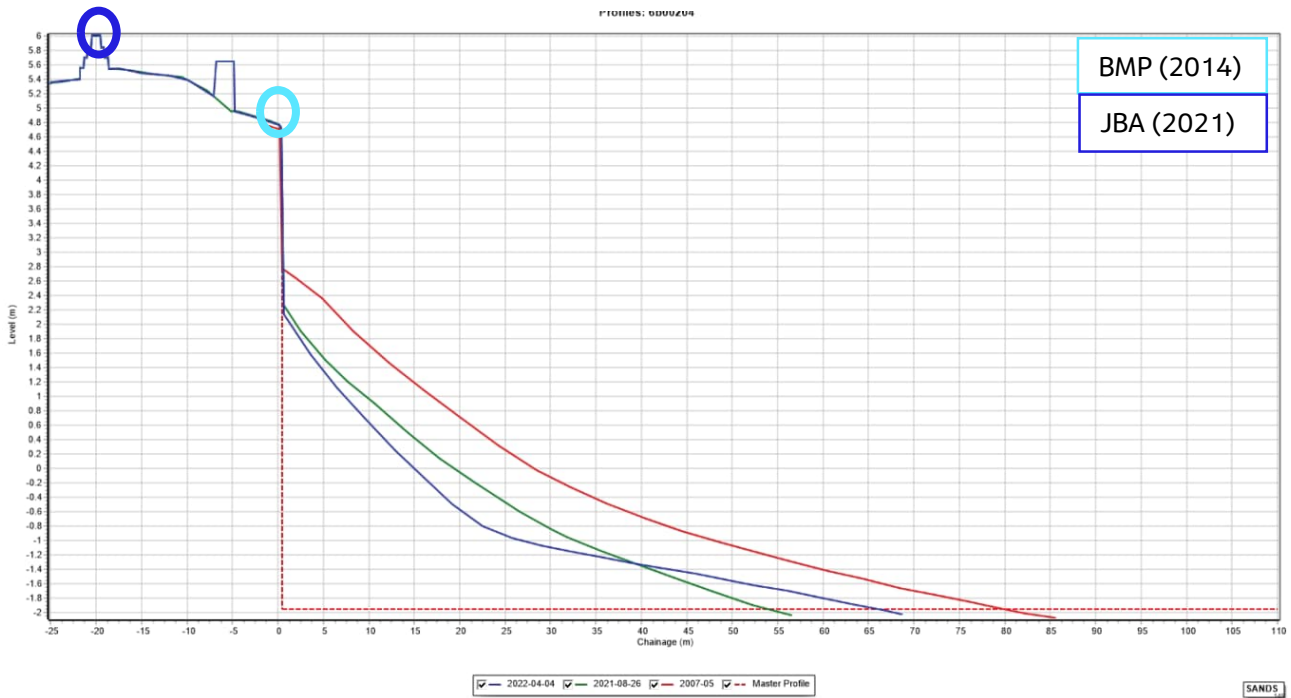

Figure 2-5: SWRCMP data (2022) for Profile 6b00204 with crest levels used in the BMP and JBA overtopping analyses highlighted.

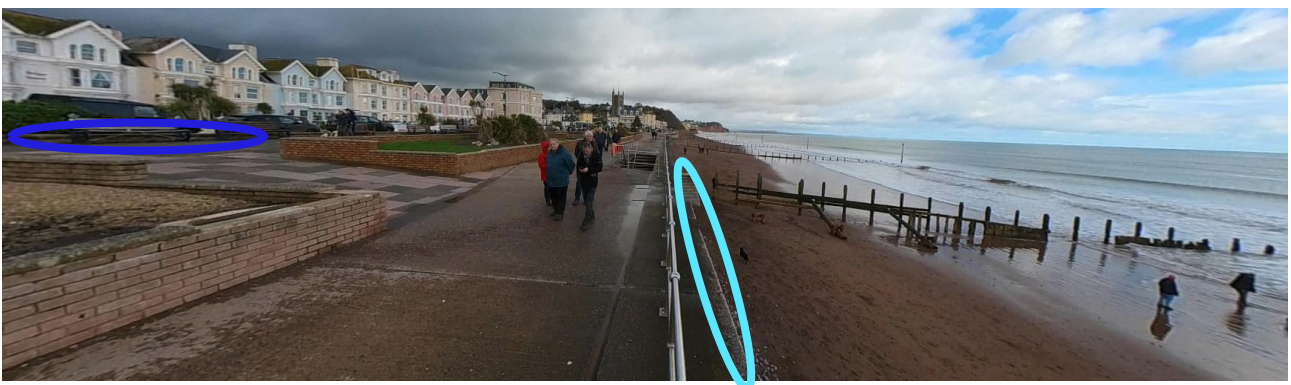

Figure 2-6: Photos from a recent site walkover at the rough location of the profile 6b00204 with crest levels used in the BMP and JBA overtopping analyses highlighted light blue and dark blue respectively.

2.3 Wave conditions

To further understand any potential differences in the overtopping results from the two analyses, the input wave and water level conditions are compared in the table below. The JBA (2021) report provided conditions

at the toe of the structures. However, the BMP (2014) provided them offshore. For this comparison, the BMP conditions were transformed to the toe of the structures (as stated in the BMP (2014)) using Goda. In the case of TEI_05 and TEI_06, where the profiles have not been considered in the previous BMP, offshore wave conditions have been transformed to the toe provided in JBA (2021).

It can be seen that the JBA wave heights and water levels are generally slightly higher which would be expected from seven years of climate change.

Table 2-2: Wave Conditions used in JBA (2021) and BMP (2014).

Section Name		Wave Height (m)		Wave Period (s)		Water level (mODN)	
JBA (2021)	BMP (2014)	JBA (2021)	BMP (2014)	JBA (2021)	BMP (2014)	JBA (2021)	BMP (2014)
TEI_01	6b00191	1.82	1.42	6.87	9.68	3.32	3.19
TEI_02	6b00198	1.58	2.32	7.47	9.68	3.23	3.19
TEI_03	6b00204	1.63	0.68	8.21	9.68	3.15	3.19
TEI_04	6b00216	2.05	2.28	7.26	11.40	3.15	3.03
TEI_05	SHALDON	1.26	1.00	7.57	9.81	3.13	3.11
TEI_06	SHALDON	1.06	0.87	7.85	9.94	3.04	3.05
TEI_07	6b00212	2.26	1.91	7.15	10.20	3.23	2.88
TEI_08	6b00204	0.00	0.68	0.00	9.68	0.00	3.19

In the case of profile TEI_08 from JBA, no wave height, period or water level is provided. The reason for this is unclear. In JBA (2021b) it states that where the still water level overflows the top of the structure the wave overtopping discharge is reduced to zero to avoid double counting as the inundation model accounts for still water level flooding separately. However, it may instead be the case that no waves overtop this structure in present day epoch and as such no associated overtopping wave condition can be presented. It is unclear why the wave height, period and water level are also set to zero in the report.

3. Overtopping

3.1 Results from previous reports

The summary of the overtopping results from both JBA (2021) and BMP (2014) can be found in Table 3-1.

Table 3-1: Overtopping results from both JBA (2021) and BMP (2014) for a 1 in 200-year Return Period

Section Name		Overtopping Discharge (l/s/m)					
JBA (2021)	BMP (2014)	Present Day		2070	2062	2120	2112
		JBA (2021)	BMP (2014)	JBA (2021) ¹	BMP (2014)	JBA (2021) ¹	BMP (2014)
TEI_01 ¹	6b00191	1	183	4	420	19	1367
TEI_02	6b00198	0	54	1	109	8	280
TEI_03	6b00204	12	30	46	156	112	2138
TEI_04	6b00216	51	605	118	696	261	3443
TEI_05	SHALDON	2	-	24	-	41	-
TEI_06	SHALDON	0	-	15	-	130	-
TEI_07	6b00212	55	341	127	1359	170	19248
TEI_08 ¹	6b00204	0	30	0	156	1	2138

¹ Denotes where crest levels vary significantly this will impact the overtopping rate

In some of the cases overtopping results are not comparable due to the differences in crest heights, as mentioned in section 2.2, this will significantly impact the overtopping rate recorded in the two reports. The differences in overtopping rates increase further for future epochs with the BMP analysis finding considerably larger rates for 2112 than JBA found for 2120. Input wave conditions were not available to compare for future epochs. The BMP analysis also carried out sensitivity testing and did find that the results were highly sensitive to beach levels. This highlights the importance of ensuring appropriate trigger levels are in place that will prevent low beach levels being reached.

3.2 Standard of Protection (SoP)

3.2.1 Overtopping Limits

All defences included within this analysis are close to public walkways. The standard of protection against structural damage has been determined using a tolerable discharge of 200 l/s/m. The standard of protection for public safety has been assessed using limit of 0.3 l/s/m. These tolerable limits are detailed in the EurOtop manual from 2007 and 2018 respectively, see Figure 3-1 and Figure 3-2.

Table 3.5: Limits for overtopping for damage to the defence crest or rear slope

Hazard type and reason	Mean discharge
	q (l/s/m)
Embankment seawalls/sea dikes	
No damage if crest and rear slope are well protected	50–200
No damage to crest and rear face of grass covered embankment of clay	1–10
No damage to crest and rear face of embankment if not protected	0.1
Promenade or revetment seawalls	
Damage to paved or armoured promenade behind seawall	200
Damage to grassed or lightly protected promenade or reclamation cover	50

Figure 3-1: Extract from EurOtop (2007) indicating tolerable overtopping discharges for structural damage.

Table 3.3: Limits for overtopping for people and vehicles

Hazard type and reason	Mean discharge q (l/s per m)	Max volume V _{max} (l per m)
People at structures with possible violent overtopping, mostly vertical structures	No access for any predicted overtopping	No access for any predicted overtopping
People at seawall / dike crest. Clear view of the sea.		
H _{m0} = 3 m	0.3	600
H _{m0} = 2 m	1	600
H _{m0} = 1 m	10-20	600
H _{m0} < 0.5 m	No limit	No limit
Cars on seawall / dike crest, or railway close behind crest		
H _{m0} = 3 m	<5	2000
H _{m0} = 2 m	10-20	2000
H _{m0} = 1 m	<75	2000
Highways and roads, fast traffic	Close before debris in spray becomes dangerous	Close before debris in spray becomes dangerous

Figure 3-2: Extract from EurOtop (2018) indicating tolerable overtopping discharges for public safety.

It is recommended that the minimum SoP for structural stability should be below the overtopping limit for a minimum of a 1 in 200-year return period condition, while, for public safety, the overtopping rate should be below the overtopping limit for a minimum of a 1 in 1 year Return period.

3.2.2 Resulting Standard of Protection

3.2.2.1 Teignmouth

Royal Haskoning DHV (2014) determined that overtopping increased negligibly/minimally from 2013 to 2014. Changes since then are likely not sufficient to alter the assessment of SoP. For future epochs, while the previous BMP analysis used old climate projections (UKCP09), the calculated overtopping rates were higher than those of the JBA analysis (2021) which used the latest projections (UKCP18). Therefore, the results are still likely to be conservative.

Table 3-2: Standard of protection at Teignmouth based on BMP (2014) overtopping rates and EurOtop (2007) and EurOtop II (2018) tolerable limits.

Section Name		Present Day (2014)		2062		2112	
JBA (2021)	BMP (2014)	Structural SoP	Public Safety SoP	Structural SoP	Public Safety SoP	Structural SoP	Public Safety SoP
TEI_01	6b00191	1 in 200	1 in <1	1 in 10	1 in <1	1 in 5	1 in <1
TEI_02	6b00198	1 in 500	1 in <1	1 in 200	1 in <1	1 in 100	1 in <1
TEI_03	6b00204	1 in 500	1 in 10	1 in 200	1 in 1	1 in 10	1 in <1
TEI_04	6b00216	1 in 50	1 in <1	1 in 10	1 in <1	1 in 1	1 in <1
TEI_07	6b00212	1 in 50	1 in <1	1 in 1	1 in <1	1 in <1	1 in <1
TEI_08	6b00204	1 in 500	1 in 10	1 in 200	1 in 1	1 in 10	1 in <1

Note Red text denotes where the SoP is below a 1 in 200 yr RP event and therefore insufficient.

As can be seen in Table 3-2, a number of the sections calculated above are deemed to provide an insufficient SoP. Particular cross sections of concern are TEI_04 (which reaches the limit under present day conditions), TEI_01 (which reaches the limit for public safety in the present day and then structurally in 2062) and TEI_07 (which reaches the limit under present day conditions). TEI_02, TEI_03 and TEI_08 reached the structural limit in the year 2112 but reach the limit for public safety in the present day, 2062 and 2112 respectively.

3.2.2.2 Shaldon

The Shaldon coastline on the South side of the River Teign was not considered in the BMP (2014) due to a lack of profile monitoring. As such, JBA (2021) results have been adopted to determine standards of protection as shown in Table 3-3.

Table 3-3: Standard of protection at Shaldon based on JBA (2021) overtopping rates and EurOtop II (2018) tolerable limits.

Section Name		Overtopping Discharge (l/s/m)					
JBA (2021)	BMP (2014)	Present Day		2070		2120	
		Structural SoP	Public Safety SoP	Structural SoP	Public Safety SoP	Structural SoP	Public Safety SoP
TEI_05	SHALDON	1 in >1000	1 in 20	1 in >1000	1 in <200	1 in >1000	1 in <200
TEI_06	SHALDON	1 in >1000	1 in 200	1 in >1000	1 in <200	1 in >1000	1 in <200

Since JBA (2021b) have not conducted an overtopping assessment in the year 2070 and 2120 for return periods other than 1 in-200 and 1 in 1000 years, commentary can only be made as to whether the overtopping limits have been reached for those conditions. In the case of TEI_05, it is reasonable to suggest that the SoP for public safety will be less than 1 in 20-year return period for the year 2070 and 2120 based on the return period conditions in the present day.

Based on the results from JBA (2021b) it is unlikely that overtopping will be the cause of structural failure of this coastline.

As with the BMP (2014), no profile monitoring data is available on the Shaldon frontage. Therefore, no check can be made on the levels provided in JBA (2021) with which the overtopping rates have been calculated.

With the profiles along the Teignmouth Open Coast some of the levels were found to be related to the overall coastal flood inundation rather than structural overtopping which is required for standard of protection assessment. The results should therefore be considered as indicative only. It is recommended that for future structural determinations more monitoring is required to improve data collections at Shaldon.

4. Conclusions

To conclude, overtopping analysis from JBA (2021) and BMP (2014) has been considered as a way to indicate the current, 50-year and 100-year standard of protection. Overtopping limits from EurOtop II (2018) and EurOtop (2007) have been used to determine public safety and structural limits, respectively. The assessment shows that parts of the frontage (TEI_04 and 07) have a present-day SoP against structural failure of less than 1 in 200. Most of the frontage has a SoP for public safety of less than 1 in 1. By 2112 the whole frontage is expected to have a SoP against structural failure of less than 1 in 200 and less than 1 in 1 for public safety.

Based on the JBA (2021) results for Shaldon it can be determined that overtopping is unlikely to be the cause of structural failure. The standard of protection in terms of public safety cannot be fully commented on based on the limited analysis undertaken in the year 2070 and 2112.

5. References

CH2MHILL, 2014. Teignmouth & Shaldon Beach Management Plan (BMP)

EurOtop, August 2007. Wave Overtopping of Sea Defences and Related Structures: Assessment Manual.

EurOtop, 2018. Manual on wave overtopping of sea defences and related structures. An overtopping manual largely based on European research, but for worldwide application. Van der Meer, J.W., Allsop, N.W.H., Bruce, T., De Rouck, J., Kortenhaus, A., Pullen, T., Schüttrumpf, H., Troch, P. and Zanuttigh, B., www.overtopping-manual.com.

JBA, 2021a. Devon and Cornwall Coastal Flood Risk Modelling-Summary Report, Version 3.0

JBA, 2021b. Devon and Cornwall Coastal Flood Risk Modelling-Model Development Report, Version 4.0

Plymouth Coastal Observatory, 2022. Southwest Regional Coastal Monitoring Programme- Annual Survey Report- Dawlish Warrant to Start Point 2022

Royal Haskoning DHV, 2014. Site 5- Teignmouth

Appendix C. Environmental Baseline

Environmental Baseline

Document no: 1

Version: P04

Teignbridge District Council

Teignmouth Beach Management Plan

25 September 2025

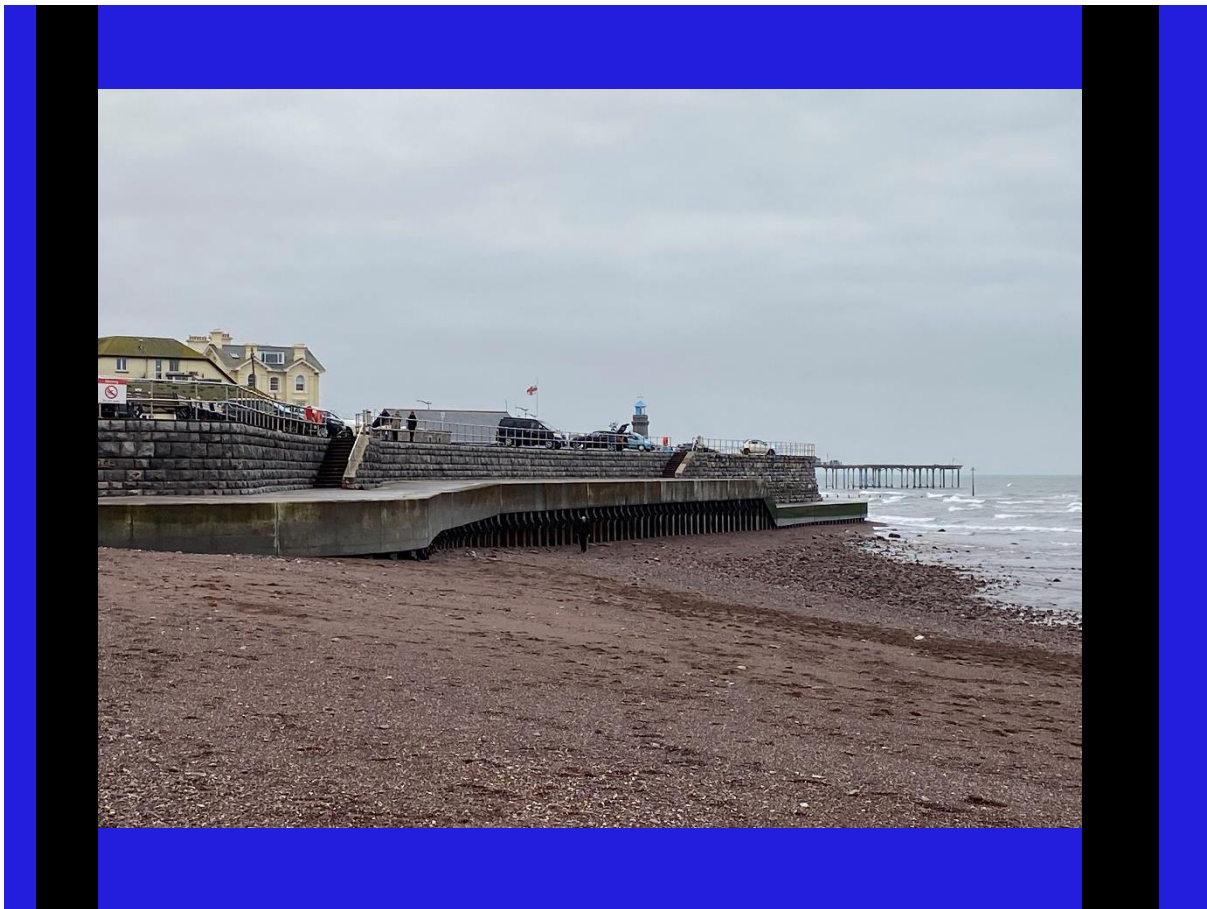

Environmental Baseline

Client name:	Teignbridge District Council	Project no:	B2471100
Project name:	Teignmouth Beach Management Plan	Project manager:	Emma Allan
Client reference:	<i>[Client reference]</i>	Prepared by:	Isabel Lee-Elliott, Corinna Morgan
Document no:	1	File name:	Teignmouth BMP_Environmental Baseline_P04
Version:	P04		
Date:	25 September 2025		

Document history and status

Version	Date	Description	Author	Checked	Reviewed	Approved
0.1	13/03/2024	Draft for internal review	IL-E	CM	CM	EA (03.04.24)
0.2	11/04/2024	Draft for Client review	IL-E	CM	CM	EA (17.04.24)
0.3	18/09/25	Final for Client (minor updates, including MMO license details)	IL-E	CM	CM	EA (18.09.25)

Distribution of copies

Version	Issue approved	Date issued	Issued to	Comments
3	EA	18.09.25	TDC	TDC review completed – no comments to address. Final for Client issue.
4	EA	25.09.25	TDC	Amendment to Figure 1.1.

Jacobs U.K. Limited

Aperture @ Pynes Hill, Rydon Lane
Exeter, EX2 5AZ
United Kingdom

T +44 (0)118 946 7000
www.jacobs.com

© Copyright 2025 Jacobs U.K. Limited. All rights reserved. The content and information contained in this document are the property of the Jacobs group of companies ("Jacobs Group"). Publication, distribution, or reproduction of this document in whole or in part without the written permission of Jacobs Group constitutes an infringement of copyright. Jacobs, the Jacobs logo, and all other Jacobs Group trademarks are the property of Jacobs Group.

NOTICE: This document has been prepared exclusively for the use and benefit of Jacobs Group client. Jacobs Group accepts no liability or responsibility for any use or reliance upon this document by any third party.

Contents

1. Introduction.....	5
1.1 Background and study area.....	5
1.2 Report content	5
1.3 Limitations and data gaps.....	8
2. Environmental setting	10
2.1 Physical setting	10
2.2 Overview of environmental designations	10
2.2.1 Environmental designations within the study area.....	10
2.2.2 Environmental Designations near the study area	11
2.3 Geomorphology and coastal processes	11
2.3.1 Geological conservation sites.....	11
2.3.2 Geomorphology and sediment transport.....	11
2.3.3 Sediment quality	11
2.4 Ecology.....	12
2.4.1 Designated nature conservation sites.....	12
2.4.2 Habitats.....	12
2.4.3 Protected and notable species	13
2.4.4 Birds.....	14
2.4.5 Mammals.....	16
2.4.6 Fish.....	16
2.4.7 Invertebrates.....	17
2.4.8 Flora	17
2.5 Fisheries	17
2.5.1 Commercial fishing.....	17
2.5.2 Recreational fishing	19
2.6 Transportation and navigation	19
2.6.1 Transportation.....	19
2.6.2 Marine navigation	19
2.7 Landscape and seascape.....	20
2.7.1 Landscape Designations.....	20
2.7.2 Landscape character	20
2.7.3 Tree Preservation Orders	22
2.8 Historic environment	23
2.8.1 Designated archaeology and cultural Heritage	23
2.8.2 Non-designated archaeology and cultural heritage	23
2.9 Water	26
2.9.1 WFD water bodies	26

2.9.2	WFD protected areas	26
2.10	Land and marine use.....	27
2.10.1	Amenity value.....	27
2.10.2	Landfill.....	28
2.10.3	Air quality	29
3.	Consents and licensed activities.....	30
3.1	Licences and consents.....	30
3.2	Existing licensed activities	30
4.	Relevant plans and strategies.....	32
4.1	Durlston Head to Rame Head Shoreline Management Plan (SMP2)	32
4.1.1	Holcombe to Teignmouth The Point.....	32
4.1.2	Teign Estuary - The Point to Shaldon	32
4.1.3	Shaldon (The Ness) to Tor Point.....	33
4.2	Local Plan 2013-2033 – Teignbridge.....	33
4.3	South Devon Catchment Flood Management Plan	33
4.4	South Marine Plan.....	34
4.5	River Basin Management Plan	34
4.6	Coastal Access Program	34
4.7	National Planning Policy Framework	35
5.	References	36

Tables

- 1.1 Environmental baseline topics
- 2.1 Protected and notable faunal species
- 2.2 Selected records of wildfowl, wader and seabird sightings within 5km of Teignmouth since 2018
- 2.3 Landings into Teignmouth port by UK vessels: 2017

Figures

- 1.1 The study area (red outline) and BMP frontages (blue line)
- 2.1 Nature conservation
- 2.2 Landscape character types (Devon County Council Environment Viewer) and TPOs
- 2.3 Historic environment
- 2.4 Water
- 2.5 Land use

1. Introduction

1.1 Background and study area

This Environmental Baseline Report has been prepared for Teignbridge District Council to support the Teignmouth Beach Management Plan (BMP), which will inform future beach management solutions for the frontages of Teignmouth and Shaldon in Devon.

The Beach Management Plan boundaries extend from The Ness, Shaldon; the Teign Estuary as far as Shaldon Bridge, and The Point to The Parson and Clerk headland to the North. However, the BMP will set-out future management activities for a discrete length of this extent from The Ness, Shaldon to Clipper Quay, New Quay to The Point, and along the open coast, from The Point to east Cliff. These extents are shown in Figure 1.1.

Studies covering coastal processes, defences and economics are being undertaken separately and a detailed options appraisal will be completed as part of the BMP process.

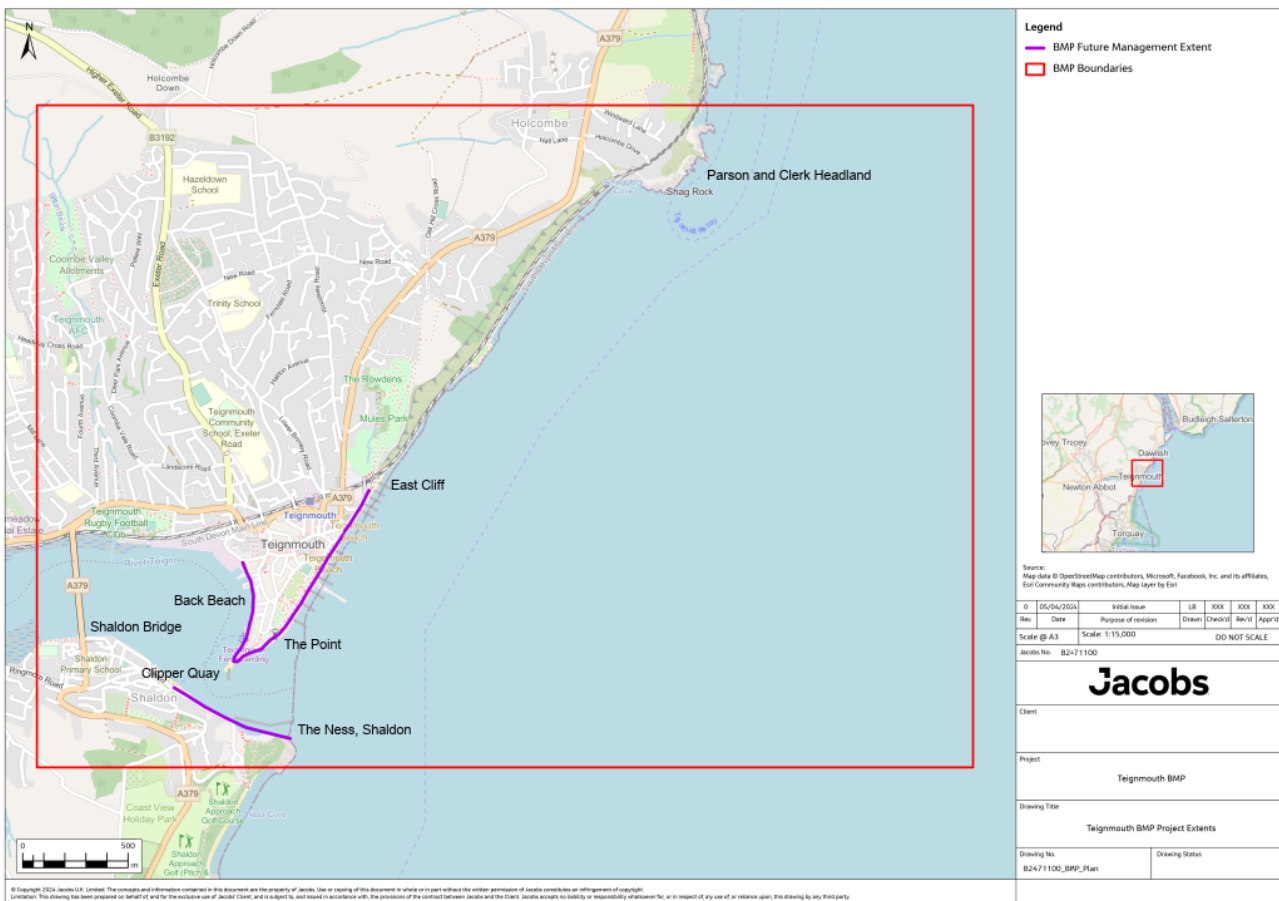

Figure 1.1 The study area (red outline) and BMP frontages (purple line).

1.2 Report content

This report has been divided into sections, with the main content of the 'Environmental Setting' presented in Section 2. This information has been prepared in line with best practice and follows recommendations made by the Beach Management Manual 2nd Edition (Rogers *et al.*, 2010) to cover specific topics. Details of the environmental topics considered in this report are presented in Table 1.1.

Table 1.1 also references relevant environmental receptors in Environmental Impact Assessment (EIA) legislation, which might require consideration as part of any EIA (see text box below) required to support future consent applications.

It should be noted that the level of detail presented in this report allows for an initial appraisal of environmental features to inform the development of an environmentally sustainable future management regime. This does not negate the requirement for future detailed environmental assessment, which may be required to support consent applications or prejudge the scope of the assessment.

Environmental Impact Assessment (EIA) procedures in EC countries are based on the European Community Directive 'The Assessment of the Effects of Certain Public and Private Projects on the Environment' (85/337/EEC) as amended by the Council Directive 97/11/EC.

The Directive was implemented in the UK through various regulations. Those regulations relevant to this BMP are considered to be:

The Town and Country Planning (Environmental Impact Assessment) Regulations 2017

These EIA Regulations apply only to the environmental impact assessment ("EIA") of certain developments which are given consent for development under the town and country planning laws of England.

The Town and Country Planning (Environmental Impact Assessment) Regulations 2017 revoke and replace the Town and Country Planning (Environmental Impact Assessment) (England and Wales) Regulations 2011, as amended, in England.

The Town and Country Planning (Environmental Impact Assessment) Regulations 2017

Paragraph 4

Within the Environmental Impact Assessment process:

(2) The EIA must identify, describe and assess in an appropriate manner, in light of each individual case, the direct and indirect significant effects of the proposed development on the following factors

- a) population and human health;*
- b) biodiversity, with particular attention to species and habitats protected under Directive 92/43/EEC(34) and Directive 2009/147/EC(35);*
- c) land, soil, water, air and climate;*
- d) material assets, cultural heritage and the landscape*

The Marine Works (Environmental Impact Assessment) Regulations 2007 (as amended)

These regulations make provision for the requirement of EIAs to be carried out prior to the granting of consent of certain regulated activities in UK waters and UK controlled waters.

Table 1.1 Environmental baseline topics.

Details of the topics covered by Section 2 ‘Environmental setting’, in context of current EIA legislation

Environmental Topics ¹	Sub-topic	Section Reference	Relevant environmental aspects outlined in The Town and Country Planning (Environmental Impact Assessment) Regulations 2017	Relevant environmental aspects outlined in The Marine Works (Environmental Impact Assessment) (Amendment) Regulations 2017
Physical setting	<ul style="list-style-type: none"> ▪ N/A 	2.1	N/A	N/A
Overview of environmental designations	<ul style="list-style-type: none"> ▪ Environmental designations within the study area ▪ Environmental designations within 2km of study area 	2.2	N/A	N/A
Geomorphology and coastal processes	<ul style="list-style-type: none"> ▪ Geological conservation sites ▪ Geomorphology and coastal processes ▪ Sediment quality 	2.3	Land Soil	Soil
Ecology	<ul style="list-style-type: none"> ▪ Designated nature conservation sites ▪ Habitats ▪ Protected and notable species 	2.4	Biodiversity, with attention to protected species and habitats	Fauna and flora
Fisheries	<ul style="list-style-type: none"> ▪ Commercial fishing ▪ Recreational fishing 	2.5	Material assets including the architectural and archaeological heritage, Population and human health, Material Assets	Fauna and flora, Human beings, Material assets and Cultural heritage
Transportation and navigation	<ul style="list-style-type: none"> ▪ Transportation ▪ Marine navigation 	2.6	Material Assets including the architectural and	Human beings, Material assets,

Environmental Topics ¹	Sub-topic	Section Reference	Relevant environmental aspects outlined in The Town and Country Planning (Environmental Impact Assessment) Regulations 2017	Relevant environmental aspects outlined in The Marine Works (Environmental Impact Assessment) (Amendment) Regulations 2017
			archaeological heritage	Landscape and Cultural heritage
Landscape and seascape	<ul style="list-style-type: none"> ▪ National landscape designations ▪ Landscape character ▪ Tree Preservation Orders 	2.7	Cultural heritage and the landscape	Landscape, cultural heritage
Historic environment	<ul style="list-style-type: none"> ▪ Designated archaeology and cultural heritage ▪ Non-designated archaeology and cultural heritage 	2.8	Material assets, cultural heritage and the landscape	Material assets, landscape and cultural heritage
Water	<ul style="list-style-type: none"> ▪ Water Framework Directive (WFD) water bodies ▪ WFD protected areas 	2.9	Water, population and human health	Human beings, fauna and flora, and water
Land and marine use	<ul style="list-style-type: none"> ▪ Amenity value ▪ Contaminated Land ▪ 	2.10	Population and human health, material assets, soil	Human beings, fauna and flora, soil and material assets
Air Quality	<ul style="list-style-type: none"> ▪ Air quality 	2.11	Air and climate, population and human health	Human beings, air and climate

¹Topics sourced from the Beach Management Manual 2nd Edition, Rogers *et al.*, 2010.

1.3 Limitations and data gaps

The level of detail within this baseline report is considered to be proportionate to the study area identified.

This report has been produced as a desk-based study, hence without site surveys. All information contained within this document has been identified from open source, public domain, and readily available information and is presumed accurate at the time of writing. Owing to limitations of these information sources, this report should not be considered a comprehensive description of all possible constraints or opportunities associated with beach management interventions.

No consultation has been carried out as part of this baseline report nor has this been refined in line with statutory consultees or key stakeholders.

The following were excluded from the scope of this baseline report due to limited data availability at this high level stage and/or are not considered to influence the selection of management interventions. This data will require further consideration during the detailed design and appraisal of future schemes.

- Flora and fauna
 - Surveys of protected and invasive species
 - Review of biological records from Devon Biodiversity Records
- Landscape and seascape
 - Local landscape character, locally designated landscapes and visual amenity
- Historic environment
 - Non-designated heritage features – a detailed review of individual heritage sites/finds from Devon's Historic Environment Records
- Water
 - Groundwater protection zones and aquifers
- Land and marine use
 - Individual community facilities and properties
 - Individual tourist assets including restaurants, cafes, accommodation (such as hotels, bed and breakfast and holiday cottages), car parking, visitors centres and recreational attractions
 - Landownership
 - Infrastructure, utilities, ground conditions/UXO/geotechnical conditions, areas of contaminated or made ground
 - Agri-environmental schemes/environmental land management agreements
 - Planning applications and land/employment/housing allocations
- Legislative or policy changes that may influence beach management interventions.
- Noise
 - Baseline data on existing background noise levels. These may be required prior to any management activities depending on their scale and potential to produce elevated levels of noise.
- Services and utilities
 - No statutory searches have been undertaken as part of this baseline review. A full and up-to-date search would need to be completed for any design and operational considerations.

2. Environmental setting

2.1 Physical setting

As outlined in Section 1.1 the study area for this report is the stretch of coast from Holcombe to The Ness at Shaldon which encompasses the BMP frontage where beach management interventions may occur.

Receptors/sites considered near the study area are those where there is a potential pathway for impact (for example, that are hydrologically linked) or could be expected to be within a tidal excursion up and down the coastline (e.g. approximately 2km).

The settlements of Teignmouth and Shaldon lie within the study area at the mouth of the Teign Estuary. Teignmouth is a seaside town and residential area on the northern bank of the Teign Estuary bordering Lyme Bay, and the village of Shaldon is located on the opposite southern bank of the Teign Estuary in South Devon. The wider marine area near the study area is important for biodiversity; however, the study area itself does not comprise any sites of nature conservation designation/importance.

Running west of the town of Teignmouth and Shaldon is the River Teign and Teign Estuary, known to be an important shellfishery (from the A379 bridge up the River Teign) and is also a migratory route for Atlantic salmon (*Salmo salar*). The estuary also supports recreational and commercial activities including the port of Teignmouth just inside the mouth of the estuary, a historic passenger ferry and various clubs associated with water sports.

The coastline and estuary frontage within the study area consists of sandy beaches backed by cliffs at Holcombe (to the north of Teignmouth) and Shaldon, a concrete seawall at Teignmouth itself and by the Teignmouth to Dawlish railway line just to the north of Teignmouth. This railway runs along the northern (left bank) of the Teign Estuary, before passing through Teignmouth and then following the coast immediately landward of the seawall northwards to Holcombe and beyond, cutting through a tunnel at Sprey Point. A prominent landmark seaward of Teignmouth is Teignmouth Pier which was constructed in the 1800's.

Teignmouth is situated within the lower estuary which comprises a number of geomorphological features, which interact with coastal, estuarine and fluvial processes to determine the estuary's behaviour and evolution. On the southern side of the estuary is a cliffed headland, called 'The Ness' which comprises a sand/shingle beach with large pebbles/rocks at the base of the cliffs and extends along the length of Shaldon. Extending into the estuary mouth from the northern shoreline is a spit (Den Spit) which has been almost entirely built over by the town of Teignmouth and has been stabilised with a series of concrete seawalls to form The Point.

2.2 Overview of environmental designations

A summary of the designated, non-designated sites, and important ecological features relevant to the study area is provided in the subsequent sections.

2.2.1 Environmental designations within the study area

The environmental designations within the study area, which are listed below, are central in the consideration of delivering BMP options along the frontage:

- Shaldon Regionally Important Geological Site - see Section 2.3.1.
- County Wildlife Sites (CWS) – Babbacombe Bay Cliffs, The Parson and Clerk, Teign Estuary and Teignbridge/Torbay border to Shaldon Ness - see Section 2.4.1
- Designated heritage assets including Listed Buildings and Conservation Areas – see Section 2.8.1
- Water Framework Directive (WFD) sensitive habitats – see Section 2.9

- WFD Protected Areas - Bathing Waters (Teignmouth Town, Shaldon, Ness Cove and Teignmouth Holcombe) and Teign Estuary East shellfish waters – see Section 2.9
- Teignmouth Air Quality Management Area - see Section 2.10.3

2.2.2 Environmental Designations near the study area

Further environmental designations that are located near to the study area may also require consideration in the BMP, depending on the options selected, and include:

- Lyme Bay and Torbay Special Area of Conservation (SAC) – see Section 2.4.1
- Exe Estuary Special Protection Area (SPA) – see Section 2.4.1
- Dartmoor SAC – see Section 2.4.1
- Dawlish Cliffs Site of Special Scientific Interest (SSSI) – see Section 2.3.1
- Labrador Bay RSPB Reserve – see Section 2.4.1
- Designated heritage assets including Listed Buildings and Conservation Areas – see Section 2.8.1
- WFD sensitive habitats - see Section 2.9
- WFD protected areas - Dawlish Coryton Cove and Dawlish designated Bathing Waters and Teign Estuary West shellfish waters - see Section 2.9

2.3 Geomorphology and coastal processes

2.3.1 Geological conservation sites

The only local geological conservation site within the study area is Shaldon Regionally Important Geological Site (RIGS), located at SX93957201 and designated for its red breccias, sandstones and mudstones of the Teignmouth Breccias.

Dawlish Cliffs geological SSSI (see Figure 2.1) is located 970m to the north of Holcombe and designated for its exposures of interbedded Aeolian sands (Dawlish Sands) and water-laid, breccia-filled, fluvial channels of Permian age.

2.3.2 Geomorphology and sediment transport

A full review of the geomorphology and sediment transport within the BMP study area is presented in the Coastal Processes Baseline, Appendix A to the full BMP report.

2.3.3 Sediment quality

At the time of writing this report, the only information made available regarding sediment quality in the area comprise a number of grab samples collected and analysed as part of the last phase of the project (CH2MHill, 2014). The sediment analysis indicated a D_{50} range of sediment grain size as being between 0.2mm and 5mm. No chemical analysis of the samples was undertaken.

These samples were taken from the navigation channel and nearshore area and not the beaches along the foreshore.

2.4 Ecology

2.4.1 Designated nature conservation sites

There are four County Wildlife Sites (CWS - non-statutory local wildlife sites) located within the study area (Devon Biodiversity Records Centre) (see Figure 2.1), as follows:

- Babbacombe Bay Cliffs
- The Parson and Clerk
- Teign Estuary
- Teignbridge/Torbay border to Shaldon Ness

With the exception of The Parson and Clerk CWS, the CWS' all border parts of the BMP frontage.

There are no statutory nature conservation sites within the study area. The closest statutory nature conservation sites to the study area (see Figure 2.1) are:

- International
 - The closest site is Lyme Bay and Torbay SAC (designated for reefs and submerged or partially submerged sea caves), located approximately 3km to the south of the study area. The reefs extend over a large area on outcropping bedrock distant from the shore and have the potential to be affected by changes in coastal processes from beach management interventions.
 - The nearest SPA and Ramsar site is the Exe Estuary, located approximately 7km north of the study. It is possible that qualifying birds may use the Teign Estuary for feeding and roosting.
 - The headwaters of the River Teign is within the Dartmoor SAC, which has Atlantic salmon listed as a qualifying feature.
- National
 - The closest site is Dawlish Cliffs geological SSSI, located 970m to the north of Holcombe (see Section 2.3.1).
- Local
 - The coastal Labrador Bay RSPB reserve is situated approximately 470m to the south of the study area and 750m to the south of the Teign Estuary. This site has been designated to provide habitat for circl bunting (*Emberiza circlus*), which has a very restricted range in the UK (i.e. south Devon). Peregrine falcons (*Falco peregrinus*) are also found at the reserve (www.rspb.org.uk, 2024). These species may utilise the coastline within the study area e.g. peregrine around the cliffs.

2.4.2 Habitats

The open coastline around the study area comprises mainly intertidal and subtidal sediments and seawall/maritime cliff habitat landward with rocky shore and subtidal rocky reef also present.

The following priority habitats (under Section 41 of the Natural Environment and Rural Communities Act (NERC) are potentially represented within, or in close proximity to the study area (see Figure 2.1):

- Maritime cliffs and slopes – located at The Ness on the southern side of the Teign Estuary and along part of the cliffed area between the north end of Teignmouth and Sprey Point.
- Mudflats – located generally upstream of Shaldon Bridge within the Teign Estuary.
- Saltmarsh – located generally upstream of Shaldon Bridge within the Teign Estuary.

Environmental Baseline

- Deciduous woodland – areas located to the north of the study area and north of Shaldon Approach Golf Course on the southern side of the estuary.
- Mussel beds (*Modiolus modiolus*, *Mytilus edulis* and others) – located upstream of Shaldon Bridge within the Teign Estuary.
- Seagrass beds – located 250m offshore of Holcombe.
- Traditional orchard – areas around Holcombe.

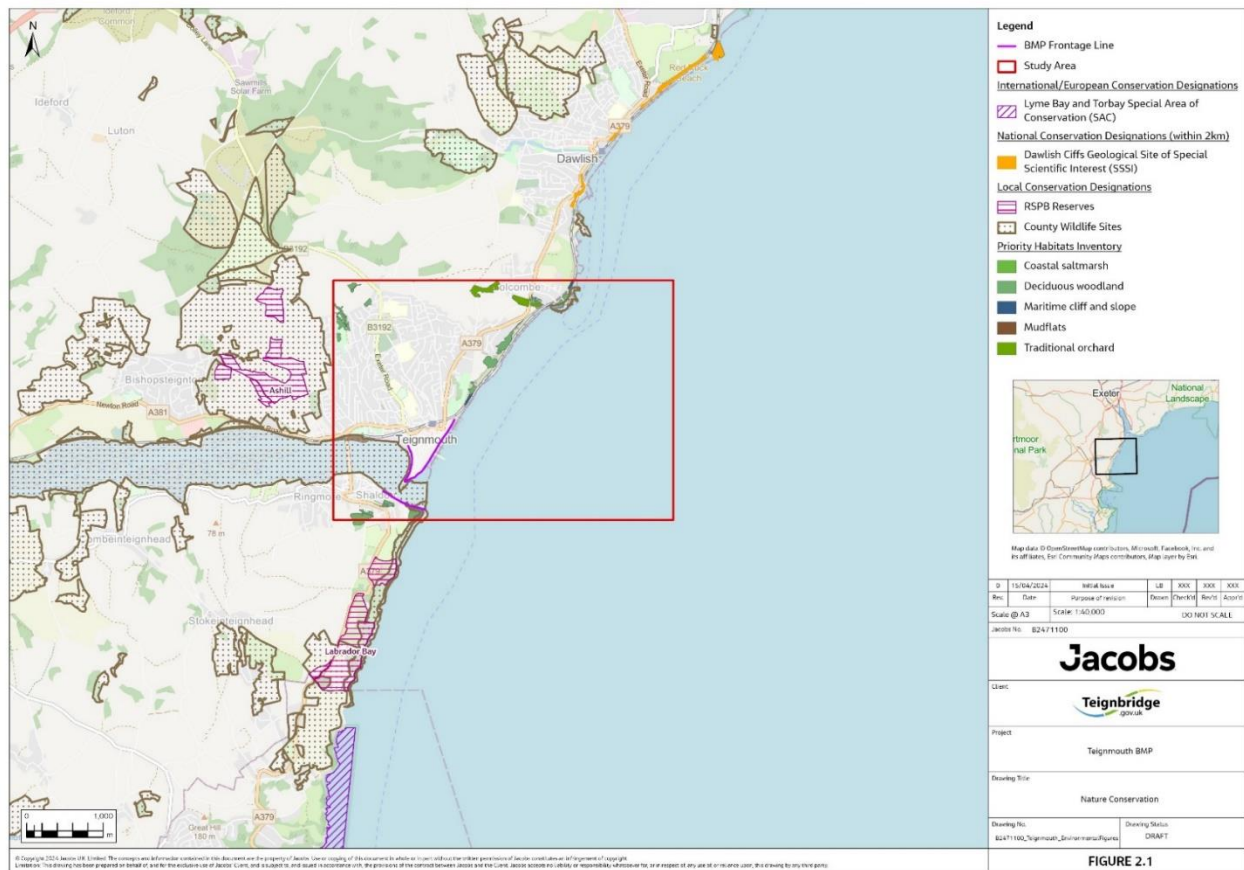

Figure 2.1 Nature conservation.

2.4.3 Protected and notable species

Protected and notable faunal species described in subsequent sections that are expected to be in the study area owing to historic records and/or being a feature of nearby designated sites are summarised in Table 2.1.

Table 2.1 Protected and notable faunal species.

Species	Designations
Mammals	
Otter (<i>Lutra lutra</i>)	NERC Section 4.1 species EC Habitats Annex II and IV; Wildlife and Countryside Act
Birds	
Sandwich tern (<i>Thalasseus sandvicensis</i>)	EC Birds Directive Annex 1 species
Great Northern diver (<i>Gavia immer</i>)	EC Birds Directive Annex 1 species
Roseate tern (<i>Sterna dougalli</i>)	EC Birds Directive Annex 1 species
Little tern (<i>Sternula albifrons</i>)	EC Birds Directive Annex 1 species
Bar-tailed godwit (<i>Limosa lapponica</i>)	EC Birds Directive Annex 1 species
Lapwing (<i>Vannellus vanellus</i>)	NERC Section 4.1 species
Curlew (<i>Numenius arquata</i>)	NERC Section 4.1 species
Dark-bellied brent goose (<i>Branta bernicla bernicla</i>)	NERC Section 4.1 species
Common tern (<i>Sterna hirundo</i>)	EC Birds Directive Annex 1 species
Mediterranean gull (<i>Ichthyaeus melanocephalus</i>)	EC Birds Directive Annex 1 species
Red-throated diver (<i>Gavia stellata</i>)	EC Birds Directive Annex 1 species
Avocet (<i>Recurvirostra avosetta</i>)	EC Birds Directive Annex 1 species
Little gull (<i>Hydrocoloeus minutus</i>)	EC Birds Directive Annex 1 species
Fish	
Atlantic salmon (<i>Salmo salar</i>)	EC Habitats Annex II (freshwater only); Annex V; NERC Section 4.1 species; protected under the Salmon and Freshwater Fisheries Act 1975
Sea trout (<i>Salmo trutta</i>)	NERC Section 4.1 species
European eel (<i>Anguilla anguilla</i>)	NERC Section 4.1 species IUCN Critically endangered; protected under the Eels Regulations (England and Wales) 2009
River lamprey (<i>Lampetra fluviatilis</i>)	EC Habitats Annex II and V; NERC Section 4.1 species

2.4.4 Birds

There are records of numerous species of wildfowl, wader and other birds in the coastal zone off Teignmouth. High level data since 2018/19 available from the NBN gateway (BTO/JNCC partnership data, confirmed sightings) indicate the following species are present (records.nbnatlas.org, 2024):

Table 2.2 Selected records of wildfowl, wader and seabird sightings within 5km of Teignmouth since 2018²

Note: Species in bold are EC Birds Directive Annex 1 species and those asterisked are NERC section 41 species

Species	Scientific name	Species	Scientific name
Herring gull	<i>Larus argentatus</i>	Great Northern diver	<i>Gavia immer</i>
Cormorant	<i>Phalacrocorax carbo</i>	Roseate tern	<i>Sterna dougallii</i>
Oystercatcher	<i>Haematopus ostralegus</i>	Grey plover	<i>Pluvialis squatarola</i>
Little egret	<i>Egretta garzetta</i>	Arctic skua	<i>Stercorarius parasiticus</i>
Black-headed gull	<i>Chroicocephalus ridibundus</i>	Little tern	<i>Stemula albifrons</i>
Greater black backed gull	<i>Larus marinus</i>	Fulmar	<i>Fulmarus glacialis</i>
Shelduck	<i>Tadorna tadorna</i>	Bar-tailed godwit	<i>Limosa lapponica</i>
Common scoter	<i>Melanitta nigra</i>	Knot	<i>Calidris canutus</i>
Curlew*	<i>Numenius arquata</i>		
Shag	<i>Gulosus aristotelis</i>	Lesser black-backed gull	<i>Larus fuscus</i>
Mallard	<i>Anas platyrhynchos</i>	Black swan	<i>Cygnus atratus</i>
Turnstone	<i>Arenaria interpres</i>	Common guillemot	<i>Uria aalge</i>
Mute swan	<i>Cygnus olor</i>	Eider	<i>Somateria mollissima</i>
Sandwich tern	<i>Thalasseus sandvicensis</i>	Wigeon	<i>Mareca penelope</i>
Red-breasted merganser	<i>Merganser serrator</i>	Razorbill	<i>Alca torda</i>
Dunlin	<i>Calidris alpina</i>	Kittiwake	<i>Rissa tridactyla</i>
Redshank	<i>Tringa totanus</i>	Teal	<i>Anas crecca</i>
Grey heron	<i>Ardea cinerea</i>	Lapwing*	<i>Vanellus vanellus</i>
Gannet	<i>Morus bassanus</i>	Common tern	<i>Sterna hirundo</i>
Mediterranean gull	<i>Ichthyaetus melanocephalus</i>	Yellow-legged gull	<i>Larus michahellis</i>
Ringed plover	<i>Charidrius hiaticula</i>	Manx shearwater	<i>Puffinus puffinus</i>
Greenshank	<i>Tringa nebularia</i>	Velvet scoter	<i>Melanitta fusca</i>
Great crested grebe	<i>Podiceps cristatus</i>	Long-tailed duck	<i>Clangula hyemalis</i>
Red-throated diver	<i>Gavia stellata</i>	Balearic shearwater	<i>Puffinus mauretanicus</i>
Moorhen	<i>Gallinula chloropus</i>	Avocet	<i>Recurvirostra avosetta</i>
Canada goose	<i>Branta canadensis</i>	Snipe	<i>Gallinago gallinago</i>
Sanderling	<i>Calidris alba</i>	Greylag goose	<i>Anser anser</i>
Common sandpiper	<i>Actitis hypoleucos</i>	Iceland gull	<i>Larus glaucooides</i>
Common gull	<i>Larus canus</i>	Great skua	<i>Stercorarius skua</i>
Dark-bellied brent goose*	<i>Branta bernicla bernicla</i>	Shoveler	<i>Spatula clypeata</i>
Whimbrel	<i>Numenius phaeopus</i>	Little gull	<i>Hydrocoloeus minutus</i>
Gadwall	<i>Mareca strepera</i>	Black tern	<i>Chlidonias niger</i>
Tufted duck	<i>Aythya fuligula</i>	Garganey	<i>Spatula querquedula</i>

² <https://records.nbnatlas.org/explore/your-area#50.5470|-3.4967|12|Birds>

Species	Scientific name	Species	Scientific name
Black-tailed godwit	<i>Limosa limosa</i>	Spotted redshank	<i>Tringa erythropus</i>
Green sandpiper	<i>Tringa ochropus</i>	Glaucous gull	<i>Larus hyperboreus</i>

2.4.5 Mammals

The Environment Agency recorded otter (*Lutra lutra*) around the coastal area of Teignmouth between 2007 and 2017³ and it is therefore likely that otter utilise the intertidal habitats within the study area.

Recent records of marine mammals have identified that grey seal (*Halichoerus grypus*) has been sighted (October 2023) at Watcombe Beach, Torbay just south of the study area. Approximately 10-20 common dolphin (*Delphinus delphis*) have also been sighted (August 2023) south of the study area, off Dartmouth⁴.

2.4.6 Fish

The River Teign is an important river for migratory fish such as Atlantic salmon (*Salmo salar*) and brown/sea trout (*Salmo trutta*). European eel (*Anguilla anguilla*) and river lamprey (*Lampetra fluviatilis*) also use the river. These are species of conservation importance (with salmon being a feature of the Dartmoor SAC upstream), which migrate through the estuary at certain stages of their life cycle. The Environment Agency (2020) states that the River Teign salmon stock is currently 'At Risk' of failing the Management Objective (defined as attaining the conservation limit $\geq 80\%$ of the time) and represents a continuing deterioration of the salmon stocks since the last assessment in 2015.

The River Teign Estuary is a bass nursery area. The Bass (Specified Areas) (Prohibition of Fishing) (Variation) Order 1999 prohibits fishing for bass, or fishing for any species of sea fish using sand eels (*Ammodytidae* spp) as bait, by any fishing boat within any part of the River Teign bass nursery area between 30th April and 1st November.

Ellis *et al.* (2012) note that the waters in the English Channel just off Teignmouth are utilised by the following marine fish species as spawning/nursery grounds:

- Spurdog (*Squalus acanthias*), low intensity spawning
- Thornback ray (*Raja clavata*), low intensity nursery
- Spotted ray (*Raja montagui*), low intensity nursery
- Whiting (*Merlangius merlangus*), low intensity nursery
- Anglerfish (*Lophius piscatorius*), low intensity nursery
- Sandeel (*Ammodytidae*), low intensity spawning
- Mackerel (*Scomber scombrus*), high intensity nursery
- Plaice (*Pleuronectes platessa*), low intensity nursery
- Dover sole (*Solea solea*), low intensity spawning and nursery

³ <https://records.nbnatlas.org/explore/your-area#50.5470|-3.4967|12|Mammals>

⁴ <https://www.seawatchfoundation.org.uk/recent sightings/>

2.4.7 Invertebrates

As outlined in Section 2.4.2 and 2.5.1, the Teign Estuary supports commercially important bivalve species. No specific marine invertebrate data have been obtained but it is expected that the sedimentary habitats around the open coast frontage and estuary are important in supporting benthic infaunal communities.

2.4.8 Flora

The open coastline seawall/maritime cliff habitat and rocky shore/ subtidal rocky reef provide substrate for various species of macroalgae in places where conditions are suitable. However, the stretches of intertidal finer sediments along the open coast do not provide such substrate, and there would only be limited habitat for macroalgae in the areas interspersed with cobbles or where there are groynes/other coastal structures which includes opportunistic green macroalgae higher up the beach.

As outlined in Section 2.4.1, there is a large subtidal seagrass (*Zostera marina/angustifolia*) stand offshore of Holcombe (250m at the closest point) in the northern section of the study area stretching to the south of the Exe Estuary. It has been described as possibly the largest single seagrass site in England (approximately 1,000ha). This seagrass site in Lyme Bay may have historically (in 2005) supported ~20% of the total UK seagrass coverage, although more data are required to ascertain this (Brown *et al.*, 2022).

Upstream in the River Teign, saltmarsh stands are present mainly on the northern bank although these appear over 2.5km away from the study area.

2.5 Fisheries

2.5.1 Commercial fishing

The Teign Estuary is a designated shellfish water under the Shellfish Waters Directive, comprising two areas, Teign Estuary (East) and Teign Estuary (West). Within the Teign Estuary (East) water are Classified bivalve harvesting areas for mussels (*Mytilus*), which are Class B and C and harvesting areas for Pacific oyster (*Magellana gigas*) which are Class B.

The study area is within the Devon and Severn Inshore Fisheries and Conservation Authority's (IFCA) district.

The Teign has offshore crabbing vessels, trawlers and inshore boats operating out of the estuary area. The Fish Quay provides the main area in Teignmouth for commercial fishing. It is leased to the Teign Fishermen and Watermen's Association by Teignbridge District Council. UK Sea Fisheries statistics data indicate that around 30 species were targeted in 2017 and landed at Teignmouth. The largest catch of finfish species landed at Teignmouth in 2017 were sprat and sardine (approximately 1030 and 212 tonnes, respectively) with whiting and mackerel also caught in large volumes (around 20 tonnes annually). Crabs, whelks and scallops were the top three catches in terms of shellfish (Table 2.3).

Table 2.3 Landings into Teignmouth port by UK vessels: 2017⁵

Species	Quantity (tonnes)	Value (£,000)
Bass	1.29	14.96
Brill	0.10	0.65
Catfish	0.00	0.00
Cod	0.32	1.00

⁵ https://assets.publishing.service.gov.uk/media/5ba8c47fe5274a55c3407c3e/Chapter_3_Landings.xls

Environmental Baseline

Conger Eels	0.15	0.12
Dabs	0.11	0.11
Dogfish	4.66	1.06
Flounder or Flukes	0.58	0.25
Gurnard	0.38	0.30
Hake	0.00	0.01
Lemon Sole	2.59	12.15
Ling	0.02	0.03
Monks or Anglers	0.10	0.25
Plaice	2.03	3.66
Pollack (Lythe)	2.70	6.91
Sand Eels	0.51	1.08
Skates and Rays	2.25	3.47
Sole	0.59	6.66
Turbot	0.42	3.25
Whiting	20.26	11.59
Other Demersal ^(a)	1.37	2.40
Fish Roes	0.06	0.16
Total Demersal	40.49	70.06
Herring	0.30	0.06
Mackerel	22.06	6.70
Sardines	212.26	70.78
Sprats	1029.37	249.10
Other Pelagic	27.69	27.99
Total Pelagic	1291.69	354.64
Crabs	61.69	174.00
Cuttlefish	0.35	1.53
Lobsters	7.05	98.33
Scallops	36.34	97.63
Squid	0.23	1.85
Whelks	100.09	110.17
Other Shellfish	0.00	0.01
Total Shellfish	205.76	483.52
Total All Species	1,538	908

a) Includes fish livers

2.5.2 Recreational fishing

The mouth of the Teign Estuary attracts recreational fishing from the shore. It is reported to have abundant mullet (*Mugilidae*), bass (*Dicentrarchus labrax*) and flounder (*Platichthys flesus*), with mackerel (*Scomber scomber*) targeted in summer⁶.

Salmon and sea trout are also commonly fished between March and September, for which a rod licence is needed from the Environment Agency to use fly or spinner only (no bait fishing is permitted) within certain defined areas of the Teign.

The public are allowed to take shellfish from the shoreline where they have a right of access and there is no limit to the weight allowed to be collected. However, Teignbridge Environmental Health investigate where necessary to check that the shellfish is not entering the commercial food chain. There are various other restrictions to the public in the lower Teign including some prohibited areas e.g. seaward of Shaldon Bridge to the mouth owing to low mussel stocks (notified in 2020) or being classified as commercial shellfishery areas (Teignbridge District Council, 2020).

2.6 Transportation and navigation

2.6.1 Transportation

The main transport route in the study area is the A379, which runs north to south from Holcombe to Shaldon, around the coastline near the Port and over Shaldon Bridge.

There is also a coastal railway line (see Figure 2.5) which runs immediately landward of the Teignmouth seawall in places and through a tunnel in the north of the study area. In the south, it follows the northern bank of the River Teign before turning south towards Torquay.

2.6.2 Marine navigation

The commercial port of ABP Teignmouth is located within the study area and the BMP frontage borders the eastern side of the port. This is a minor cargo port serving the south-west of England, just inside the mouth of the estuary. It is visited by ships mostly handling clay, timber and grain. The lower reaches of the river are navigable up to Newton Abbot, although now only to shallow draft boats and those less than 2.9m high due to the Shaldon Bridge. The navigation channel and channel approaches are regularly dredged by Teignmouth Harbour Commissioners.

The Teignmouth to Shaldon historic passenger ferry (England's oldest passenger ferry) operates a continuous daily service (restricted service in winter months) within the study area between Teignmouth back beach (near Teignmouth lifeboat station) and Shaldon. Teignbridge District Council still retain the 'rights' to the crossing and own No.4 ferry, which was built in 1946. The service itself is run privately by a local company.

The area is also popular for recreational sailing and power craft with regular regattas at the local sailing clubs of Shaldon and Teignmouth. Local sailing/rowing clubs in the study area include (but are not exclusive to):

- Teign Corinthian Yacht Club
- River Teign Rowing Club
- Seasports Southwest (sailing school)
- BOAT (Boat Owners Association Teignmouth)
- Shaldon Regatta Ltd (Rowing Club)

⁶ Fishing in Devon A Sea Angler's Guide. Available at: <https://www.fishmag.co.uk/fishing-in-devon/> [Accessed March 2024]

- River Teign Moorings (temporarily closed)

Teignmouth lifeboat station is located at The Point Car Park within the study area. This houses 'The Two Annes'; a B class Atlantic inshore lifeboat (Atlantic 85). The lifeboat is kept in the original 1862 boathouse.

There is also a commercial fishing fleet that operates out of Teignmouth (Section 2.5.1).

Any future beach management scheme will need to consider potential impacts upon these uses of the estuary.

2.7 Landscape and seascape

2.7.1 Landscape Designations

There are no National Landscapes, Heritage Coasts or other national landscape designations within the study area.

2.7.2 Landscape character

The baseline landscape and seascape character of the study area has been assessed and classified by various landscape character assessments (LCA). The relevant features are summarised below.

2.7.2.1 National landscape character areas

The study area is located within the Devon Redlands National Character Area (NCA) (NE425) ([National Character Area profiles - GOV.UK \(www.gov.uk\)](#)), characterised by its New Red Sandstone and red soil dominated landscape evident through ploughed fields, red coastal cliffs and exposures at Teignmouth, as well as gently rolling hills, small enclosed fields, copses and steep sided, flat bottomed valleys.

The River Teign breaks through the sandstone cliffs into an estuary comprising reedbeds, saltmarsh, mudflats and grazing marshes, protected by a sand spit extending from a long beach. The estuary flows eastwards to join the sea between Shaldon and Teignmouth. The landscape to the south of the estuary comprises undulating hills and small valleys, which fall steeply to the estuary and coast in the east.

Of particular note in the NCA is the importance of Teignmouth, which grew as a seaside resort through the late Georgian and Victorian periods, particularly after the arrival of the railway in 1846. Teignmouth is noted as having a long history as a *'small seaport, fishing town and market town, with a flourishing trade until the early 19th century in granite (from adjoining Dartmoor), pipe clay, manganese and timber. It is thought that ship building, which continues today, began in at least the 17th century. The port is now important for the export of ball and fire clay, extracted in the adjoining South Devon NCA'* ([NCA Profile:148: Devon Redlands - NE425 \(naturalengland.org.uk\)](#)). Teignmouth is characterised by late Georgian and early Victorian architecture, including some notable features such as the Grand Pier.

2.7.2.2 Regional landscape character areas

The study area comprises a range of landscape character types ([Devon County Council Environment Viewer](#)), as shown on

Figure 2.2, categorised as unique geographical areas sharing similar landscape characteristics. Those within or bordering the SMP frontage include: -

- Lower rolling farmed and settled valley slopes (3b) – covers the BMP frontage of Shaldon bordering the estuary and is typically characterised by:
 - Gently rolling lower valley slopes interspersed with pastoral farmland with variable field patterns and sizes and a wooded appearance

- Settled, with varied settlement size, building ages and styles
- Presence of leisure-related development often associated with the coast
- Winding, often narrow sunken lanes with tall earth banks. Main roads may dominate locally
- Streams and ditches
- Enclosed and sheltered landscape and wider views often restricted by vegetation
- Estuaries (4a) – covers the Teign Estuary and is typically characterised by:
 - Extensive area of mudflats, sand banks, marshes or large sandy bays, inundated by salt water at high tide, and often fringed with areas of saltmarsh, sand spits, lagoons and reclaimed areas of marshland
 - Nationally important habitats supporting migratory and overwintering wading birds, fish and rare plants
 - Creeks and tidal rivers highly influenced by prevailing tidal condition
 - Estuary edge can be defined by ridges, valley slopes, lowland headlands, cliffs, rocky outcrops, grazing marsh, arable fields or rough grassland
 - Low accessibility but well used for water-related recreation
 - Unsettled but can be strongly influenced by adjacent towns and development
 - Major road crossings and bridges sometimes present
 - Open and expansive landscape, with large skies
 - Majority of boat traffic comprises small, recreational boats and ferries. Small quays and jetties are found along the shoreline, often associated with settlement
- Coastal slopes and combes (4d) –covers the coastal frontage of the BMP area on the southern side of estuary and also the coastal area at Teignmouth. It is typically characterised by:
 - Individual or multiple branching valleys that can range from narrow and steep including scarp slopes to more open shallow systems
 - Coastal influence and extensive sea views. High, open and exhilarating on top slopes, grading to intimate and enclosed in lower valley where views are restricted by narrowness of combe mouth. Intimate, small-scale and enclosed in combes
 - Vegetation and broadleaved woodland, dominant in places
 - Small areas of pasture or mixed cultivation and scrub with irregular field pattern marked by often low hedgebanks
 - Extremely sparsely settled, old settlements in combes
 - Extensive coastal rights of way with steep paths down to beaches
 - Narrow winding roads and limited vehicle access to coast unless a main road follows the coast
 - Tranquil and remote in areas with limited vehicle access, contrasting with less tranquillity where main roads and main settlements are in proximity
- Cliffs (4h) - covers the coastal BMP frontage between Holcombe and Teignmouth. It is typically characterised by:
 - Steep rocky or vegetated coastal cliffs of varying heights, near-vertical in places
 - Distinctive landforms and exposed rock stratifications relating to local geology and coastal geomorphology
 - Narrow beaches, small stony coves or rocky foreshore at foot of cliffs

- Semi-natural habitats on less steep slopes, including mosaics of maritime grassland, heath and scrub
- Cliff faces support important breeding colonies of seabirds
- Predominantly treeless, although may include stretches of significant mature oak-dominated woodlands clinging to the cliff tops
- Accessible only along cliff top paths or in some places along shore
- Unsettled or very sparsely settled on less steep slopes
- Remains of historic forts may occur in commanding cliff-top positions, as well as remnants of the area's industrial past such as limekilns
- Extensive and dramatic views, reaching out to sea along the coastline and inland over ridgelines
- Exposed and sometimes wild with dominant marine influence
- A 'wild' and remote landscape with high levels of tranquillity
- Main cities and towns (7) – covers the BMP frontage on the northern side of the estuary and covers the town of Teignmouth. It is typically characterised by:
 - Large settlement over 200ha in area, where the landscape is dominated by built development but includes distinct areas of greenspace
 - Varied landform, often masked by development and only apparent when particularly pronounced
 - Nucleated historic cores, frequently including and surrounded by 19th century development, with more recent 20th century and later development on fringes

2.7.3 Tree Preservation Orders

There are Tree Preservation Orders (TPOs) for individual trees and groups of TPO areas throughout parts of the study area (see

Figure 2.2) with particular concentrations bordering:

- Coastal areas at Holcombe
- land off Woodland Avenue at Teignmouth bordering landward side of railway
- Cliffden, Teignmouth
- Individual trees at Ringmore Road, Shaldon
- The Ness, Shaldon
- The Ness Cottage, Shaldon

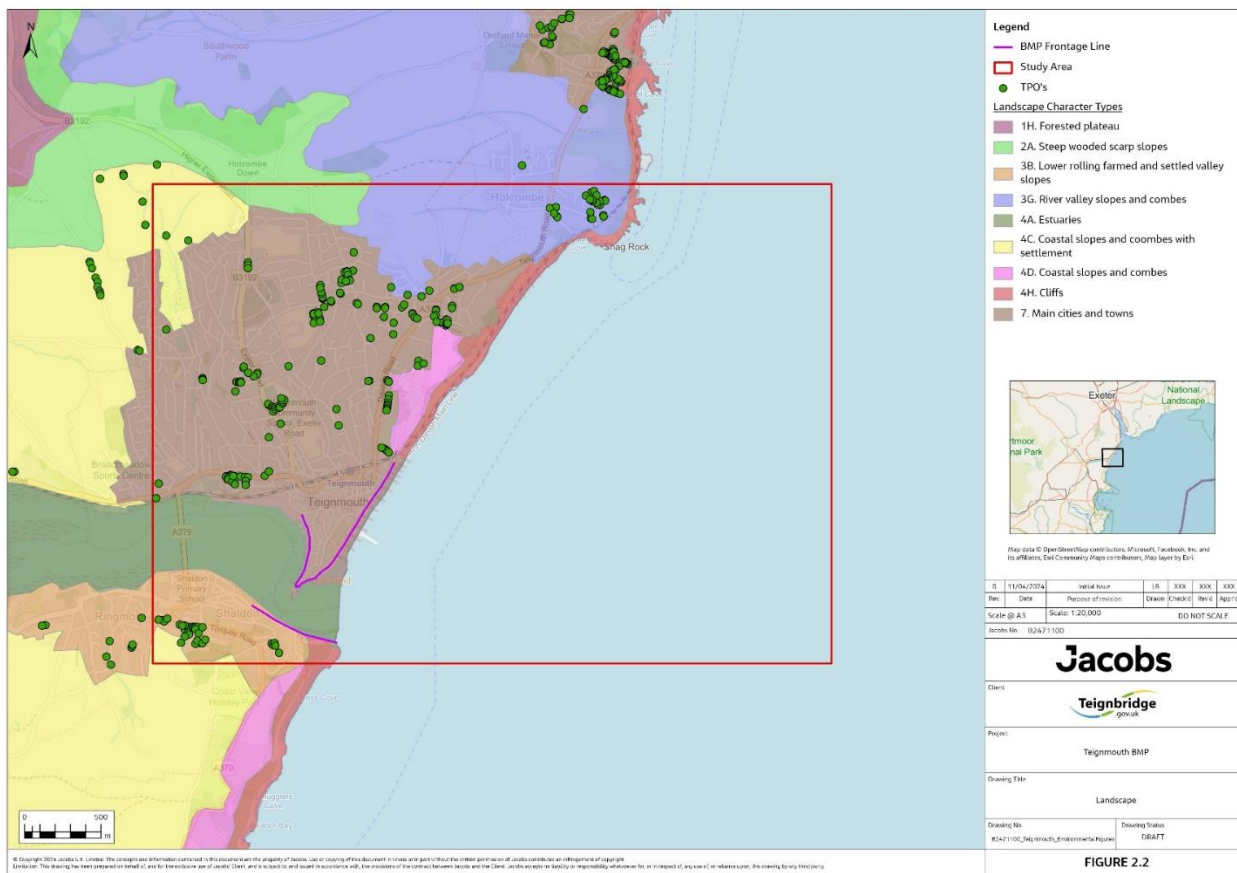

Figure 2.2 Landscape character types (Devon County Council Environment Viewer) and TPOs

2.8 Historic environment

2.8.1 Designated archaeology and cultural Heritage

There are no Scheduled Monuments, Registered Battlefields, World Heritage Sites or Registered Park and Gardens in the study area.

There are numerous Grade 2 Listed Buildings, one Grade 2* Listed Building and one Grade 1 Listed Building (Church of St Peter, adjacent to Shaldon bridge) within the study area, shown on

Figure 2.3.

There are also several Conservation Areas within the study area (some of which border the BMP frontage) including Teignmouth, Teignmouth (St James), Teignmouth (Shaldon), Teignmouth (Ringmore) and Holcombe Drive, as shown on

Figure 2.3.

2.8.2 Non-designated archaeology and cultural heritage

A Historic Environment Records data search was not undertaken and therefore a high level review was undertaken to consider the potential archaeological resource of the study area. Information available on the

Devon County Council Environment Viewer includes several Historic Environment Records along this area of coast to the north and south of the Teign Estuary⁷.

Those to the north include (but are not exclusive to) the following:

Fish Stage on the River Teign, East Teignmouth (MDV110488). A Fish Stage is labelled on the First Edition 25-inch Ordnance Survey map.

Beach Scaffolding, Teignmouth Beach (MDV105174). This is described as a *single length of a linear anti-invasion defence of Second World War date is visible as a structure running on the beach at Teignmouth. The anti-invasion structure, probably beach scaffolding, can be seen from the Promenade to the Point on aerial photographs of 1941-1943.*

Teignmouth Pier, Teignmouth (MDV9884). The Pier is cited as being *constructed in the 1860s on cast iron screw piles, and in 1890s the seaward end had a pavilion theatre, while the inner pavilion housed an early form of cinema entertainment. The pier was pierced during the Second World War as an anti-invasion measure.*

Second World War Machine Gun Position (MDV112157). *The site of a Second World Machine Gun position in Teignmouth is recorded on the National Monuments Record.*

Peat Deposit, Teignmouth (MDV107326). A peat deposit was recovered from -23.8 m OD in 1966.

Church Rocks Wreck (MDV9871). Approximately 180m off Church Rocks, East Teignmouth in approximately 3-7.5m water depth. Evidence of a 16th century wreck was found in 1975 and thought to be Venetian. The wrecked vessel has not been found; nor any documentary evidence of this. Two anchors have been located and remain on the site.

Breakwaters at Sprey Point, Dawlish (MDV109850) An area of breakwaters marked on the 1880s-1890s Ordnance Survey map at Sprey Point.

Anti-aircraft battery (MDV71889). Light World War II anti-aircraft battery off Teignmouth. Exact location not known.

Second World War Anti-Invasion Obstructions At Sprey Point (MDV105175). Pimple; barbed wire World War II anti-invasion obstructions are visible on aerial photographs of 1941.

South Devon Railway, Teignmouth Section (MDV17775). The South Devon Railway line opened as far as Teignmouth in May 1846, then on to Newton Abbot by the following December.

Sea Wall between Parsons Tunnel and Teignmouth (MDV120681). Sea wall between Parsons Tunnel and Teignmouth on the South Devon Railway. Built of sandstone with granite dressings in 1846; subsequently subject to several phases of repair and reinforcement in concrete and limestone.

There have also been finds of Portuguese, medieval and post-medieval coins found in the waters e.g. around The Point at Teignmouth, mainly between 1974 and 1987.

South of the mouth of the River Teign Estuary, the following historic features have been recorded:

Boundary stone (MDV56676). Boundary stone in the Parish of Shaldon, Teignmouth

Mediterranean Pottery from Teignmouth (Finds) (MDV28911). *Three pottery vessels of Mediterranean origin dated to the 4th century BC were discovered in an 'artificial cave' near Teignmouth in the 19th century. Although the exact findspot is unknown the grouping of different pottery types of similar date suggests they constitute a genuine deposit*

⁷ <https://maptest.devon.gov.uk/portaldvl/apps/webappviewer/index.html>

Breakwater (MDV42796). A breakwater is labelled and depicted on the Second Edition 25-inch Ordnance Survey map and the Ordnance Survey Master Map.

Shaldon Emergency Battery (MDV39548). A number of structures relating to the emergency coastal battery at Shaldon are visible on aerial photographs of 1946. Some structures remain visible along Marine Parade and in Ness Gardens.

Teignmouth Local plan identifies several heritage assets. In addition to existing listed buildings; development proposals affecting them and their setting will need to take account of their significance, character, setting and local distinctiveness. Those assets close or along the coastline include the following:

- Fisherman’s Light, Back Beach
- Old Mooring Posts, Back Beach
- The Pier
- Remaining old structure of original Fish Quay
- The seafront terraces of Courtenay Place and non-Listed Buildings in Den Promenade (Bella Vista, Eastcliffe Court, Burlington House, Thornhill, Beach Cottage, Beach Court and Lyme Bay House Hotel)
- The 3 walls at the former Morgan Giles Yard (Breakwaters and landing stages)
- Victorian Cast Iron Post, Gales Hill
- Historic Permian Sandstone / Breccia Walls (in various locations across Teignmouth)

These assets will require further review and consideration during the development of future beach management schemes.

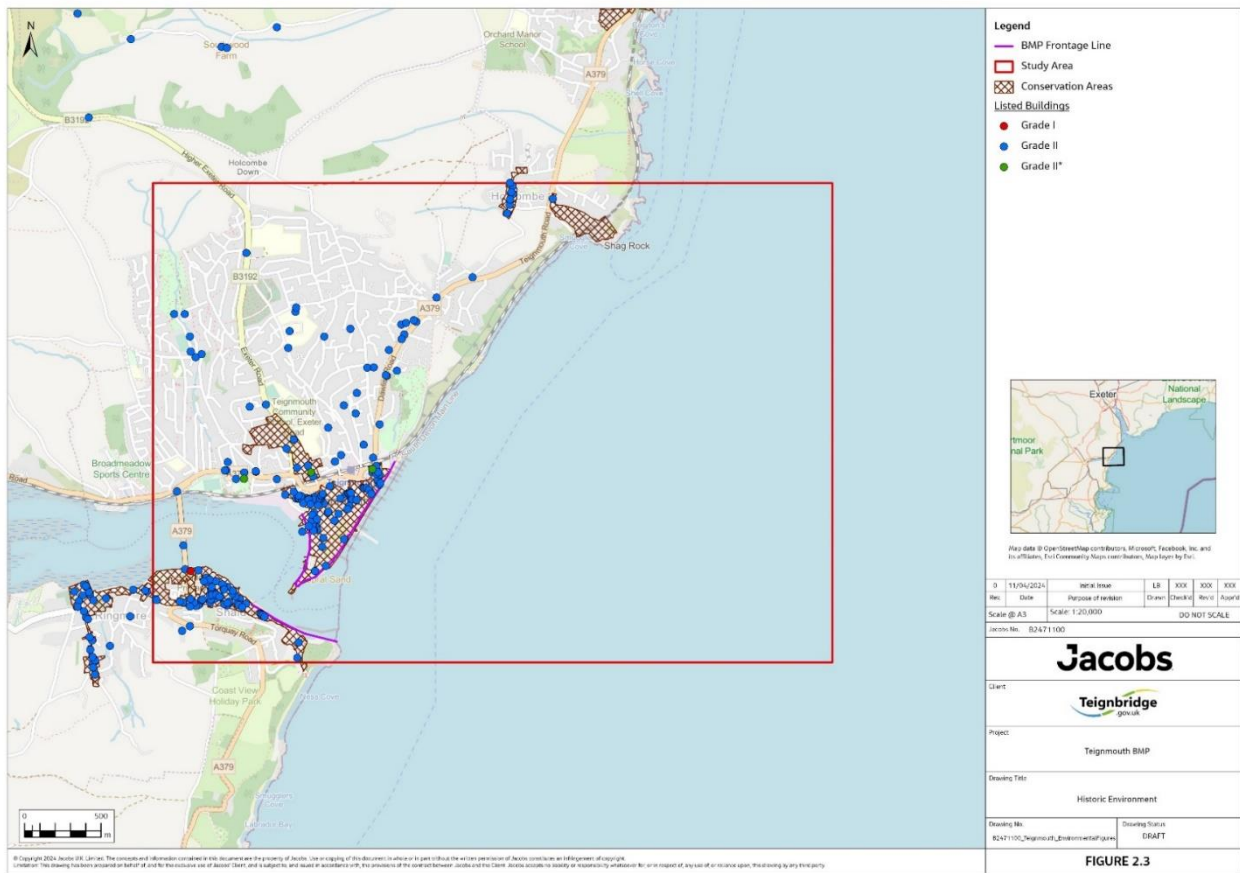

Figure 2.3 Historic environment.

2.9 Water

2.9.1 WFD water bodies

The coastline spans two coastal and transitional WFD waterbodies within the South West River Basin District as shown on Figure 2.4; the Teign (GB510804605800) transitional, partly mixed waterbody and Lyme Bay West (GB650806420000) coastal, moderately exposed waterbody. Both waterbodies are overall Moderate ecological status (2019 and 2022).

The relevant groundwater bodies within the study area are the Permian Aquifer in Central Devon (Overall Poor status (2019), owing to poor nutrient and livestock management) and Torquay (Overall Good status).

There are the following higher sensitivity WFD habitats in the Teign and coastal waters:

- Mussel beds present in River Teign, just west of the A379 bridge
- Subtidal seagrass beds present offshore of Holcombe (approximately 250m offshore at the closest point)
- Saltmarsh present 2.6km upstream in the River Teign

The following lower sensitivity habitats are also present within the study area:

- Intertidal and subtidal soft sediment, rocky shore and subtidal rocky reef

2.9.2 WFD protected areas

The Environment Agency monitors bathing water quality in line with the Bathing Water Directive at four locations within or bordering the study area (see Figure 2.4); Teignmouth Town (currently classed as Good since 2022), and Shaldon, Ness Cove and Teignmouth Holcombe (all Excellent since 2019) (environment.data.gov.uk, 2023).

The Teign Estuary East shellfish waters also fall partially within the study area, as shown on Figure 2.4.

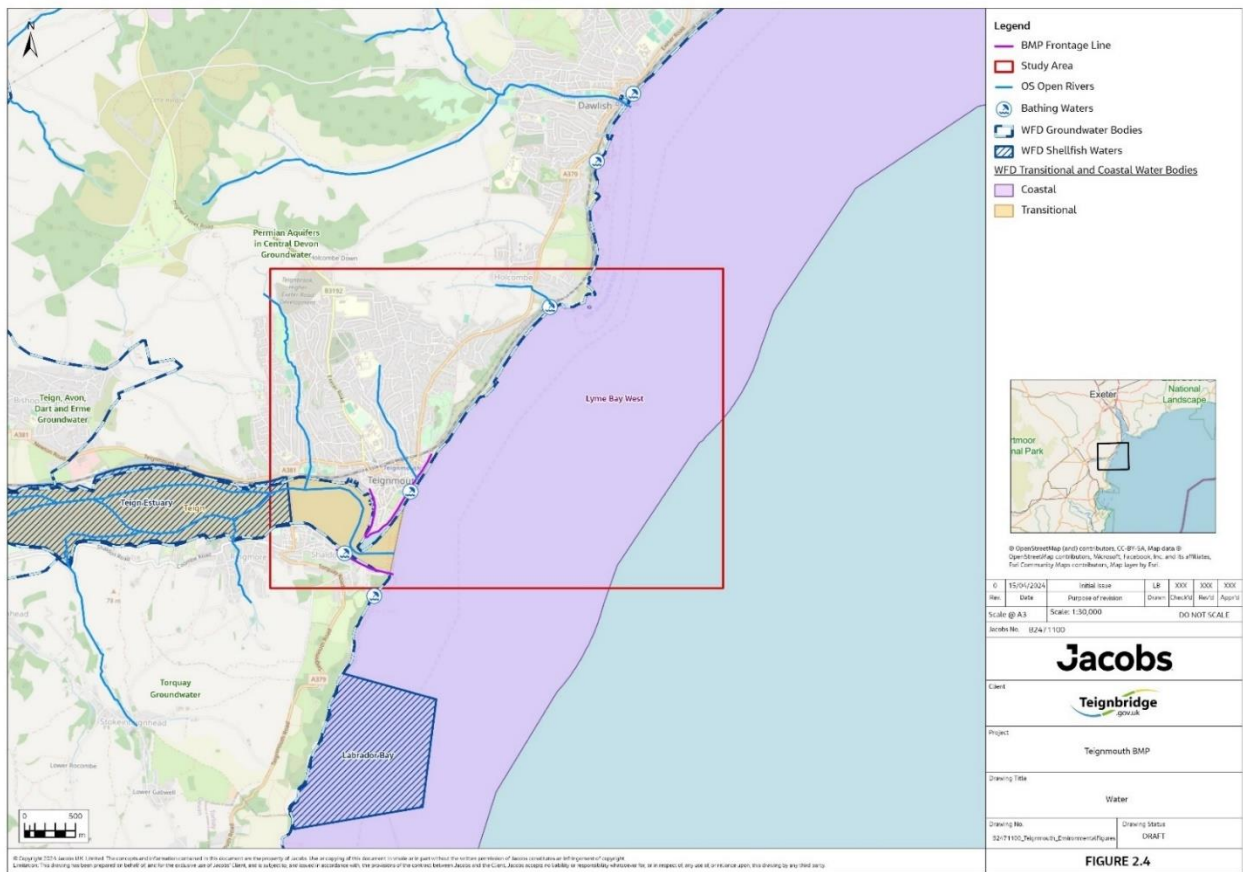

Figure 2.4 Water.

2.10 Land and marine use

2.10.1 Amenity value

The BMP frontage of the study area generally has unrestricted public access, and supports the long-distance route of the South West Coast Path National Trail (see Figure 2.5), which follows the seawall immediately inland of the study area and an amenity beach with associated businesses (e.g. cafés, boat hire etc) present.

The amenity value of the BMP frontage on the northern side of the estuary mouth (see Figure 2.5) is centred on The Point on the mouth of the River Teign, upon which is located a skate park, a Playpark and Teignmouth Lighthouse, which is a local historical landmark. Further north, the Grand Pier is another landmark and tourist attraction (including an arcade) situated along the seawall promenade on the open coast.

On the southern side of the estuary, there are less amenity features. Shaldon Approach Golf Course is situated approximately 400m to the south of the BMP frontage on the edge of the study area (see Figure 2.5) with views over the Teign Estuary.

2.10.2 Landfill

There is one area containing historic landfill sites on the north bank of the Teign Estuary just upstream of Shaldon Bridge (Broadmeadow /Broadmeadow Playing Fields)⁸, just west of the study area (see Figure 2.5). There are no known active landfill sites within the study area.

⁸ <https://data.catchmentbasedapproach.org/datasets/therivertrust::historic-landfill-sites/explore?location=50.547044%2C-3.513133%2C15.82>

3. Consents and licensed activities

3.1 Licences and consents

In order to undertake any future beach management schemes along the Teignmouth and Shaldon BMP frontages, or any associated detailed site investigations, a range of licences, approvals and consents will likely be required. These may include:

- Marine Licence from the Marine Management Organisation (MMO) under the Marine and Coastal Access Act 2009 for works below Mean High Water Spring.
- Harbour Works Licence under the Teignmouth Harbour Order 1924.
- Planning application under the Town and Country Planning Act 1990 for works above Mean Low Water.
- Crown Estate Licence – for works along the majority of the foreshore within the study area, which is owned by the Crown Estate.
- PRow diversions and closures should any be affected by future beach management interventions.
- Environmental Permit for Flood Risk Activities.

Discussions should be held with the relevant consenting organisations in a timely manner to ensure that all requirements of licence/consent applications are confirmed and addressed in order to minimise the risk of delays in being able to implement future works. These discussions should also assess the applicability of progressing a licence application through the streamlined process defined in the Coastal Concordant for England published in November 2013 (Defra, 2013).

As part of the process of obtaining a Marine Licence and planning application for undertaking beach recharge or other capital works, consideration of The Marine Works (Environmental Impact Assessment) Regulations 2007 (as amended) and the Town and Country Planning (EIA) Regulations 2017 respectively will be needed to determine whether an environmental impact assessment is required. A Water Environment Regulations Screening assessment would also be required to support these consent applications. The scope of any such assessment would require consultation with the Environment Agency.

There is one European site with potential connectivity to the study area, designated under The Conservation of Habitats and Species Regulations 2010. Therefore, the Competent Authority would likely be required to undertake a Habitats Regulations Assessment screening on any proposed works along the BMP frontages at Teignmouth and Shaldon.

3.2 Existing licensed activities

There are no current activities licensed for coastal flood and erosion risk management purposes within the study area as of March 2024.

A current active marine licence (Licence Number: MLA/2024/00433) is held by Teignmouth Harbour Commissioners for deposition of maintenance dredging material from the Teign navigation channel at Sprey Point. In the case that a beach recharge campaign were to be undertaken along this frontage, be that using material arising from the dredging of the Teign navigation channel or a different source, then a new and separate licence would need to be obtained from the MMO rather than a revision of the existing Marine Licence when that is renewed. This is because:

- The location of the work will be below the Mean High Water Springs mark, therefore enacting provision under Part 4 of the Marine and Coastal Access Act 2009 requiring a Marine Licence to be sought for the works.
- The scheme proposer (and subsequently licence holder) could be Teignbridge District Council (not Teignmouth Harbour Commissioners).

- The receiving site (i.e. beach at Teignmouth and/or Shaldon) has not previously been used as a recharge site for dredged material from local maintenance dredging and will require scientific evaluation and consultation (including statutory consultees such as Natural England, English Heritage, Devon County Council, Teignbridge District Council and the Environment Agency). NB: The MMO would act as the Competent Authority with the local authority taking the role of a statutory consultee.
- The vessel carrying out the dredging and the process for transporting material to the recharge site is not currently considered by the licence issued to Teignmouth Harbour Commissioners.

4. Relevant plans and strategies

4.1 Durlston Head to Rame Head Shoreline Management Plan (SMP2)

The Holcombe to Hope's Nose section of the Durlston Head to Rame Head SMP⁹ is cited as comprising a hard-cliffed section of coastline, with one of the main areas of development being either side Teign Estuary mouth. Long term recession of the coast is expected to be limited mainly by the resistance of the cliffs although beaches are expected to narrow along the majority of the shoreline backed by hard defences.

One of the key policy drivers, aside from environmental and geological, is to maintain the mainline railway, therefore the SMP policy is to continue to hold the existing line of defence (which will also protect a range of tourist related assets).

Within the upper Teign Estuary, an area of Managed Realignment towards the head of the estuary could help reduce flood risk within other parts of the estuary whilst also providing habitat creation opportunities.

Along the shoreline without defences, the plan is to maintain the natural coast which will deliver environmental benefits although will result in the loss of local features and agricultural land (South Devon and Dorset Coastal Advisory Group, 2011).

4.1.1 Holcombe to Teignmouth The Point

The defences at this location are cited as preventing erosion along the cliff toe and there has been negligible cliff recession over the past century therefore a lack of sediment supply to local beaches. The beach in front of the seawall has exhibited long term erosion, narrowing and coastal squeeze. In the long term, sea level rise is expected to cause the beaches backed by the seawalls to further narrow and steepen.

Along the southern part of this section of the SMP, the groynes control littoral drift with the beach historically subject to fluctuation as part of a cyclic sediment transport regime.

The local short, medium and long term policies for Holcombe to The Point (policy units 6b25 to 6b28) are to continue to maintain the existing defences under a Hold the Line Policy. For The Point (6b29) the policy is to allow the shoreline to evolve largely naturally, but allow intervention under a policy of Managed Realignment, if more detailed studies show it is required for the benefit of the wider Teign Estuary.

4.1.2 Teign Estuary - The Point to Shaldon

This estuary is constrained by the defences and steep coastline in areas without defences and the SMP considers that this area will accrete vertically in line with sea level rise and maintaining its present form. This would involve erosion in some areas which would supply sediment for this accretion along with fluvial sediment inputs. This scenario could impact the cyclic sediment circulation around the estuary mouth.

The local short, medium and long term policies for Teign Estuary: The Point; North Shore; Kingsteignton and Newton Abbot and Shaldon (policy units 6b30, 6b31, 6b33 and 6b35) are to continue to maintain the existing defences under a Hold the Line Policy.

For Teign Estuary - Passage House Hotel to Kingsteignton Road Bridge (policy unit 6b32) the preferred policy is Hold the line in the short term but investigate potential realignments. In the medium and long term, the preferred policies are to implement and continue Managed Realignment, respectively. For the Teign Estuary - South Shore (Newton Abbot to Shaldon) (policy unit 6b34) the preferred short, medium and long term policies are to continue to maintain the existing defences under a Hold the Line policy, but No Active Intervention along the currently undefended sections.

⁹ <https://southwest.coastalmonitoring.org/projects/shoreline-management-plans/sdadcag-smp2/>

4.1.3 Shaldon (The Ness) to Tor Point

This area is described as undefended coasts of geological and geomorphological value. The rate of sediment supply from cliff erosion is not expected to maintain the small beaches in the area, which could therefore disappear in the long term. Erosion of the cliff line is expected to be 10-25m by 2105

The local short, medium and long term policies for Shaldon (The Ness) to Tor Point (policy units 6b36 to 6b40) are to allow natural coastal evolution to continue through No Active Intervention.

4.2 Local Plan 2013-2033 – Teignbridge

The following Teignbridge Local Plan strategies and policies are relevant for flood and coastal erosion risk management activities:

- S2 Quality Development
- S6 Resilience
- S10 Transport Networks
- S11 Pollution
- S18 Teignmouth
- S22 Countryside
- EN2 Undeveloped Coast
- EN2A Landscape Protection and Enhancement
- EN4 Flood Risk

4.3 South Devon Catchment Flood Management Plan

The South Devon Catchment Flood Management Plan (CFMP) (Environment Agency, 2012*) acknowledges sources of flooding from rivers in the South Devon Catchment. The plan notes the following issues that are relevant, and should be considered by the BMP options:

- *Major Incident Plans have been developed for Teignmouth and Shaldon.*
- *For the Teign Estuary there are approximately 850 properties within the current 1% annual probability flood extent (1% fluvial and 0.5% tidal). Approximately 1,300 properties in the Teign Estuary are estimated to be within the future 1% annual probability flood extent.*
- *Also at risk are numerous health centres in Teignmouth and Shaldon, several schools in Shaldon, and the mainline railway between Newton Abbot and Teignmouth at several locations.*
- *There are combined fluvial/ tidal defences at Shaldon as well as tidal defences at Teignmouth (constructed in 1991). Teignmouth is also affected by wave action.*
- *The vision and preferred police option is Policy Option 5 - we can generally take further action to reduce flood risk. Future flood risk will mainly be caused by climate change, with possible sea level rises increasing the frequency and depth of future flooding. The chosen policy is considered to be the only policy to meet social and economic needs as a result of the large number of properties at risk and the potential for this to significantly increase in the future.*
- *Reducing flood risk overall will depend on working with Shoreline Management Plan policies and actions to reduce wave overtopping as well as flooding from fluvial and tidal sources.*

*During consultation held by the Environment Agency on remedial works planned for Teignmouth, the Environment Agency Catchment Team advised that the Teign catchment is a South Devon 'Focus Area'. An

evidence review is planned in 2024, with a view to update Teign Catchment plan (as part of the South Devon Catchment Partnership) (Environment Agency, 2023).

4.4 South Marine Plan

The study area falls within the Inshore area of the South Marine Plan which covers an area of around 20,000km² of inshore and offshore waters across 1,000km of coastline from Folkestone to the River Dart. It comprises one of the busiest shipping channels in the world, including freight and passenger transport alongside military activity. These activities and shipping occur alongside 60 marine protected areas, including nine marine conservation zones (MCZs) and a UNESCO world heritage site. It is one of the most complex and used areas of the English coastline.

The South Marine Plan is intended to help ensure that any marine activities occur in the appropriate locations and are undertaken correctly. It provides a framework that will shape and inform decisions over how the areas' waters are developed, protected and improved over the next 20 years.

Its vision for economic, environmental and social prosperity is to safeguard and enable sustainable use of the marine environment and encourage growth in local sectors such as tourism, and protect and enhance natural defences against climate change and flooding. This will be achieved through its 12 objectives, the use of natural capital and supporting local policies, all of which have been developed in partnership with local and national organisations, representatives and users of the area¹⁰.

4.5 River Basin Management Plan

The South West River Basin District Management Plan was prepared under the WFD as an update to the original programme produced in 2009 as part of a series of six-year planning cycles. It contains actions to improve the ecological status of water bodies in river basin catchments, including coastal waters from mean low water up to 1 nautical mile from shore. All BMP activities need to comply with the requirements of this plan. Under the WFD, the BMP options will need to ensure that they do not 'cause or contribute to deterioration in water body status' or 'jeopardise the water body achieving good status'.

During the consideration of options, the BMP must consider the potential risks to:

- Hydromorphology
- Biology – habitats
- Biology – fish
- Water quality
- Protected areas

4.6 Coastal Access Program

Natural England has investigated how to improve coastal access along a 109 km stretch of the South West Coast Path between Kingswear and Lyme Regis. On 18 March 2021, the Secretary of State announced their decision to approve this stretch of the England Coast Path between Kingswear and Lyme Regis. In relation to the study area, Natural England published the Kingswear to Lyme Regis sensitive features report (Natural England, 2017) with the following information:

Maidencombe to Holcombe

¹⁰ <https://www.gov.uk/government/collections/south-marine-plans>

The Trail: The route of the proposed trail follows the existing South West Coast Path between Maidencombe and Holcombe. The route mainly follows the coastline quite closely and maintains good views of the sea apart from at Holcombe where the trail passes inland along Teignmouth Road for a short distance. No improvements to the route are proposed. Existing signage and waymarking will be retained. Some new plaques will be added to fingerposts at key locations to show that the route is part of the England Coast Path. Since the South West Coast Path is already an international tourist destination, its inclusion as part of the England Coast path is expected to make little difference to overall visit numbers along this section of the coast.

The Coastal Margin: All land seaward and some land landward of the trail will become coastal margin.... We do not expect any noticeable increase in public use of the land either side of the route as a result of the proposals because it is already accessible. This is the case for all the margin going north as far as Maidencombe, and further north the trail runs close to the cliff edge to Shaldon. The coastal margin is very limited and well accessed past Teignmouth where the trail runs along the promenade and sea wall. The nature of the seaward coastal margin along much of the coast, much of which is steep inaccessible cliffs, means that walkers and other users will normally remain on the established trail. There is no reason to suppose members of the public would be interested in exercising their access rights to the cliff slope at these locations, since they do not do so now. Where there are existing fences, these will remain in place, providing a physical barrier which is an effective deterrent to access. Because the extent of new access rights is in keeping with already established use we don't expect there to be any noticeable change in access as a result of our proposals.

4.7 National Planning Policy Framework

The National Planning Policy Framework (NPPF) was published on 27 March 2012, revised in December 2023 and sets out the government's planning policies for England and how these are expected to be applied.

Chapter 14. Meeting the challenge of climate change, flooding and coastal change. Paragraphs 176 to 179 are particularly relevant to the Teignmouth BMP.

NPPF planning practice guidance categories that may be relevant (but not an exhaustive list) to the Teignmouth BMP include:

- Delivering Sustainable Development
- Flood risk and coastal change
- Climate change
- Conserving and enhancing the historic environment
- Natural environment
- Environmental Impact Assessment

5. References

ABPmer (2012). Teignmouth Recharge Scheme: Conceptual Understanding and Modelling Report. Report R1955, July 2012. Report produced for Halcrow Group Limited as part of the Teign Estuary Coastal Management Study.

ABPmer (2002a). Teignmouth Quay Development Environmental Statement. Report produced by ABP Marine Environmental Research Ltd., December 2002. Report reference R.984a.

ABPmer (2002b). Teignmouth Quay Development Environmental Statement: Changes to Physical Processes. Report produced by ABP Marine Environmental Research Ltd., December 2002. Report reference R.984c.

ABPmer (2006). Conceptual Understanding and Trial Dredge Assessment. Report produced by ABP Marine Environmental Research Ltd for the Teign Estuary Partnership., May 2006, Report reference R.1234.

Brown, R., Carless, D., Jackson, B., Townsend, I., Paling, N., and Tyler, C. R. (2022). Assessment of Water Quality status, drivers and impacts in the Exe Estuary Catchment and implications for ecosystem health and services including Shellfish Aquaculture. 69 pp. Available at: https://wrt.org.uk/wp-content/uploads/2022/09/Exe-Catchment-Investigation_excl-Appendices-WRT-pub-24Jul2022.pdf [Accessed January 2024]

CH2MHill (2014). Teignmouth & Shaldon Beach Management Plan. Report to Teignbridge District Council. 141 pp.

Defra (2007). Project FD2117 - Development and Demonstration of Systems Based Estuary Simulators. Available online: <http://www.discoverysoftware.co.uk/estsim/EstSim.html>. Date accessed: 23rd November 2011.

Defra (2002). Futurecoast CD. Produced by Halcrow Group Ltd for Defra.

Ellis, J.R., Milligan, S.P., Readdy, L., Taylor, N. and Brown, M.J. 2012. Spawning and nursery grounds of selected fish species in UK waters. Sci. Ser. Tech. Rep., Cefas Lowestoft, 147: 56pp.

Environment Agency (2023). Teignmouth Sea Defence Scheme Remedial Works. FCRM Pipeline Projects Internal Consultation. Form completed, July 2023.

Environment Agency (2020). River Teign migratory salmonid stock assessment and fisheries management options review. 53pp.

Environment Agency (2017). Bathing Water Quality. Available at: <http://environment.data.gov.uk/bwq/profiles/> [Accessed March 2024]

Environment Agency (2016). Part 1: South West river basin district River basin management plan. Available https://assets.publishing.service.gov.uk/media/5b2b83f2ed915d2cd5d01c40/South_West_RBD_Part_1_river_basin_management_plan.pdf [Accessed March 2024]

Environment Agency (2012). South Devon Catchment Flood Management Plan. Summary Report. Available at: https://assets.publishing.service.gov.uk/media/5a7b85dfed915d4147620ed1/South_Devon_Catchment_Flood_Management_Plan.pdf [Accessed March 2024]

Environmentdata.gov.uk (2023). 2023 Bathing Water profiles. Available at: <https://environment.data.gov.uk/bwq/profiles/> [Accessed January 2024]

Natural England (2017). Coastal Access Programme. Access and Sensitive Features Appraisal. Available at: <https://assets.publishing.service.gov.uk/media/5a82cfce40f0b6230269cd4e/kingswear-lyme-regis-sensitive-features-report.pdf> [Accessed March 2024]

Rogers, J., Hamer, B., Brampton, A., Challinor, S., Glennester, M., Brenton, P. and Bradbury, A. (2010). Beach management manual (second edition).

South Devon and Dorset Coastal Advisory Group (2011). Shoreline Management Plan Review (SMP2) Shoreline Management Plan Review (SMP2) Durlston Head to Rame Head. Halcrow report 54 pp + Appendices.

Standing Conference on Problems Associated with the Coastline (SCOPAC) (2004). Lyme Bay to South East Devon Sediment Transport Study.

Teignbridge District Council (2020). Available at: <https://teignmouthharbour.com/wp-content/uploads/2022/03/Shellfish-in-River-Teign.pdf> [Accessed January 2024]

Appendix D. Economics Baseline

Economics Baseline

Document no: Doc. No. 1

Version: 3

Teignbridge District Council

Teignmouth BMP

18 September 2025



Economics Baseline

Client name: Teignbridge District Council
Project name: Teignmouth BMP

Project no: B2471100
Project manager: Emma Allan

Document no: Doc. No. 1
Prepared by: Steve King

Version: 3
File name: Teignmouth BMP_Economics Baseline_P03

Date: 18 September 2025

Document history and status

Version	Date	Description	Author	Checked	Reviewed	Approved
1	29/04/24	First Draft	SK	JE	LKOT	EA_03.05.24
2	18/08/25	Final	SK	JE	LKOT	EA_18.08.25
3	18/09/25	Final (minor formatting amendments)	SK	JE	LKOT	EA_18.09.25

Distribution of copies

Version	Issue approved	Date issued	Issued to	Comments
3	EA	18.09.25	TDC	TDC review completed and comments addressed. Final for Client issue.

Jacobs U.K. Limited

Aperture @ Pynes Hill, Rydon Lane
Exeter, EX2 5AZ
United Kingdom

T +44 (0)139 226 9800
www.jacobs.com

© Copyright 2025 Jacobs U.K. Limited. All rights reserved. The content and information contained in this document are the property of the Jacobs group of companies ("Jacobs Group"). Publication, distribution, or reproduction of this document in whole or in part without the written permission of Jacobs Group constitutes an infringement of copyright. Jacobs, the Jacobs logo, and all other Jacobs Group trademarks are the property of Jacobs Group.

NOTICE: This document has been prepared exclusively for the use and benefit of Jacobs Group client. Jacobs Group accepts no liability or responsibility for any use or reliance upon this document by any third party.

Contents

1. Introduction.....	4
1.1 Background and study area.....	4
1.2 The basis of this report.....	5
2. Damages assessment.....	6
2.1 Flood risk damages	6
2.1.1 Limitations of assessment	12
3. Conclusions.....	14
3.1 Do-nothing damages for use in BMP appraisal.....	14
3.2 Sustain damages for use in BMP appraisal	14
3.2.1 Recommendations for further assessment.....	14
3.3 Potential beneficiaries.....	14

Tables

Table 2.1 Model grids provided (showing Return Period)	7
Table 2.2. Climate change extrapolated return periods using UKCP18 RCP 8.5 70 th percentile sea level rise (showing Return Period grids entered into Damage Calculator, unless stated otherwise).....	8
Table 2.3. Present Value £ Million Damages over 100 years under Do-Nothing Scenario.	11
Table 2.4. Present Value £ Million Damages over 100 years under Sustain Scenario.	11
Table 2.5. 2020 Property Count Flooded Above Threshold – Teignmouth.....	12
Table 2.6. 2020 Property Count Flooded Above Threshold – Shaldon.....	12

Figures

Figure 1.1 The study area (red outline) and BMP frontages (purple line).....	4
Figure 2.1. Teignmouth assumed flood risk benefit area.....	9
Figure 2.2. Shaldon assumed flood risk benefit area.....	9

1. Introduction

1.1 Background and study area

This Economics Baseline Report has been prepared for Teignbridge District Council to support the Teignmouth Beach Management Plan (BMP), which will inform future beach management solutions for the frontages of Teignmouth and Shaldon in Devon.

The BMP boundaries extend from The Ness, Shaldon; the Teign Estuary as far as Shaldon Bridge, and The Point to The Parson and Clerk headland to the North. However, the BMP will set-out future management activities for a discrete length of this extent from The Ness, Shaldon to Clipper Quay, New Quay to The Point, and along the open coast, from The Point to east Cliff. These extents are shown in Figure 1.1.



Figure 1.1 The study area (red outline) and BMP frontages (purple line).

1.2 The basis of this report

The Economics Baseline Report is a supporting document to the BMP. Studies covering coastal processes and environment are being undertaken separately and a detailed options appraisal will be completed as part of the BMP process.

This document provides details of the economic basis (i.e. the national economic damages) for both ongoing and future beach management and coastal flood and erosion risk management activities along the BMP frontage.

The economic basis for future management of this coastline is developed from an assessment of flood and erosion risk undertaken for this project to develop an updated BMP (Section 2). This assessment reflects the current condition and performance of the BMP flood and coastal erosion defences, which will influence the Do-Nothing scenario damages. The economic baseline (Do-Nothing) is summarised in Section 3.

2. Damages assessment

As part of developing the BMP for Teignmouth and Shaldon, an initial assessment of flood risk damages has been undertaken and makes use of the latest best-available data from recent studies. The following Section 2.1 describes the approach taken to assessing potential flood risk damages along the BMP extent.

To avoid double counting, no quantified assessment has been made of the coastal erosion risk damages for the BMP frontage, as damages are dominated by flood risk. There are a few properties at the northern end of the site that are at risk from erosion but not flooding. However, given high level assessment and limited number of properties these damages have not been quantified.

2.1 Flood risk damages

Depth and Hazard Rating grids were provided by the Environment Agency from the Devon and Cornwall Coastal Flood Risk Modelling study¹. These were provided in GeoTiff format, which were converted to Arc Ascii for use in Flood Modeller Suite's Damage Calculator. These are shown in Table 2.1 and

¹ JBA. (2021). *Devon and Cornwall Coastal Flood Risk Modelling study*

Table 2.2. The JBA models were developed to map flood risk for coastal communities in Devon and Cornwall based on offshore statistics, wave transformation, wave model emulation, wave overtopping and flood inundation. The modelled year was 2020 with additional climate change epochs of 2070 and 2120. The State of the Nation dataset was used to provide wave and water level boundary conditions.

Table 2.1 Model grids provided (showing Return Period).

Year	Defended Return Period Year 1 in X	Undefended Return Period Year 1 in X
2020	5, 10, 20, 30, 200, 1000	5, 10, 20, 30, 200, 1000
2070 70 th percentile	200, 1000	200, 1000
2070 95 th percentile (not used)	200, 1000	200, 1000
2120 70 th percentile	200, 1000	1000
2120 95 th percentile (not used)	200, 1000	

Table 2.2. Climate change extrapolated return periods using UKCP18 RCP 8.5 70th percentile sea level rise (showing Return Period grids entered into Damage Calculator, unless stated otherwise).

Year	Return Period Year 1 in X					
2020 Modelled Year (not entered into Damage Calculator)	5	10	20	30	200	1000
2024 extrapolated from 2020 modelling	4	8	17	25	163	737
2050 extrapolated from 2020 modelling			3	4	24	96
2070 extrapolated from 2020 modelling					4	14
2070 Modelled Year					200	1000
2123 extrapolated from 2070 modelling						2
2120 Modelled Year (used as 2123)					200	1000

Unfortunately, the model grids provided do not provide sufficient information to inform an economic assessment. Extrapolation of available grids was carried out to allow an account for climate change sea level rise in future years of the appraisal from 2024 to 2123 inclusive. This is shown in above. This enabled at least 3 Return periods to be available for each of the Average Annual Damage (AAD) years of 2024, 2050, 2070, and 2123 allowing an approximation of AAD.

It is important to note that this extrapolation is based on climate change estimates for sea level rise only.

The assumed benefit areas are shown in Figure 2.1 and Figure 2.2. These have been derived based on present day Flood Zone 3 (1:200) extent. The properties west of the benefit area for Teignmouth are primarily at risk from overtopping along the coastline not covered by the BMP. Properties west of the benefit area for Shaldon are at risk of tidal flooding via flow paths west of the defences considered in this assessment.



Figure 2.1 and 2.2 Aerial imagery courtesy of the Southwest Regional Coastal Monitoring Programme, copyright Teignbridge District Council.

Figure 2.1. Teignmouth assumed flood risk benefit area.



Figure 2.2. Shaldon assumed flood risk benefit area.

The Teignmouth (Back Beach) Tidal Defence Scheme is in the process of being constructed as part of a £4million scheme that will protect 413 properties from risk of flooding, as well as an additional 256 upper floor properties (Environment Agency website and Mid Devon Advertiser)². It should be noted, however, that this scheme only relates to protection of Teignmouth from the Teign Estuary side and does not cover the open coast defences. Insufficient information is available at this stage to be able to determine if the BMP benefit area and Teignmouth Tidal Defence Scheme benefit areas overlap and as such there has been no review of double counting undertaken for this or other local schemes.

Under a Do-Nothing scenario, it is estimated from condition surveys that the residual life of the Teignmouth defences would be around 5 years, and the Shaldon Defences around 25 years. The residual life is based on the seaward defences i.e. not the set-back flood walls. It is assumed that following the failure of the seaward defences progressive collapse of landward defences would follow soon after leading to an undefended scenario where tide levels and wave overtopping increase dramatically.

The flood damage assessment includes the following components:

- Direct property damages using National Receptor Dataset data and Multi-Coloured Handbook (MCH) 2023 depth-damage curves for short duration no warning saline flooding. Damage values are capped and/or written off based on the regional average market value of properties for the South West. The modelling of buildings used 300mm stubby footprints. This is where the modelling imprints a building polygon with height 300mm on the bare earth model representing height above door step level. This means damages will be underestimated as this is both above the recommended building threshold level and means there will be no below floor level flooding. Any new modelling for economics should use 'increased model roughness' instead of stubs.
- Emergency services: additional damage added at a rate of 5.57% of direct property damages (using this lower value as this is an urban area).
- Vehicles: If a vehicle is flooded above 0.39m (with depth offset from property flood depth), 1.33 vehicles per residential property is assumed to be damaged.
- Residential evacuation/accommodation: using the average values from the MCH tables depending on depth and property type.
- Risk to life: for residential and non-residential properties, using Damage Calculator occupancy tables and national average infirm and over 75 years old population percentages. ZUKO Hazard grids used with dummy onset grids representing very gradual flooding onset speed.
- Mental health: using the average values from the Environment Agency guidance depending on depth and property type.
- Human intangible health: Not computed for Do-Nothing damages. These are only calculated in relation to improvements in Standard of Protection over Do minimum.
- Non-residential property (NRP) indirect damages: national losses taken as 3% of NRP direct damages.

NB: The following were not considered significant for the overall economic appraisal and were not included in this assessment: agricultural damages, infrastructure damages (except, direct damage to small electricity distribution substations which are included in the NRD) and environmental benefits.

The railway is largely outside the benefit area, so benefits to the railway cannot be included. Tourism and recreation losses would largely transfer to other UK designations and would not represent a significant national loss. These are therefore not assessed at this initial stage.

Net carbon benefits (i.e. carbon damages avoided minus scheme carbon) will need to be estimated for the do something options.

² Wave of support for 'Rolls-Royce' flood defence plan | middevonadvertiser.co.uk <https://www.middevonadvertiser.co.uk/news/wave-of-support-for-rolls-royce-flood-defence-plan-256569>

Table 2.3 presents the Present Value Damages under the Do-Nothing scenario, i.e. failure at Teignmouth defences would be around five years, and the Shaldon Defences around 25 years.

Present Value damages for Teignmouth are estimated at £126.1 million. Adjusting the threshold by +/- 0.3m this could range from £89.9 million to £146.5 million.

Present Value damages for Shaldon are estimated at £3.2 million. Adjusting the threshold by +/- 0.3m this could range from £2.1 million to £3.9 million.

Table 2.3. Present Value £ Million Damages over 100 years under Do-Nothing Scenario.

	Teignmouth (£ million) 5-year life (fail in year 5)	Shaldon (£ million) 25 year life (fail in year 25)
PV damages Residential property	29.7 (24%)	1.8 (57%)
PV damages Non-Residential property	42.7 (34%)	-
PV damages Mental Health	15.1 (12%)	0.5 (15%)
PV damages Intangible Health	2.4 (2%)	0.1 (2%)
PV damages Risk to Life	13.2 (10%)	0.2 (7%)
PV damages Temporary Accommodation	5.0 (4%)	0.2 (5%)
PV damages Emergency Services	11.0 (11%)	0.2 (6%)
PV damages Vehicles	5.8 (5.8%)	0.2 (8%)
TOTAL PV damages	126.1	3.2

Table 2.4 presents the Present Value Damages under the Sustain the Standard of Service scenario. I.e. defences remain at current heights to sustain standard of service, and are replaced at current heights when they reach end of residual life during the 100 years appraisal.

Present Value damages for Teignmouth are estimated at £53.3 million. Adjusting the threshold by +/- 0.3m this could range from £25.7 million to £66.6 million.

Present Value damages for Shaldon are estimated at £2.7 million. Adjusting the threshold by +/- 0.3m this could range from £2.0 million to £3.3 million.

Table 2.4. Present Value £ Million Damages over 100 years under Sustain Scenario.

	Teignmouth (£ million) 100 year life	Shaldon (£ million) 100 year life
PV damages Residential property	12.4 (23%)	1.6 (60%)
PV damages Non-Residential property	17.9 (34%)	0 (0%)
PV damages Mental Health	7.0 (13%)	0.3 (12%)
PV damages Intangible Health	0.9 (2%)	0.1 (2%)
PV damages Risk to Life	5.7 (11%)	0.2 (6%)

PV damages Temporary Accommodation	2.0 (4%)	0.1 (5%)
PV damages Emergency Services	5.0 (9%)	0.2 (6%)
PV damages Vehicles	2.1 (4%)	0.2 (8%)
TOTAL PV damages	53.3	2.7

Table 2.5 and Table 2.6 present the property counts for present day flooding above threshold level for the defended Sustain option. The residential property counts included in the tables would count towards OM2A in a Partnership Funding Calculator.

Risk is not expected to change significantly by 2040, noting OM2B only accounts for additional climate change, not further asset deterioration.

Table 2.5. 2020 Property Count Flooded Above Threshold – Teignmouth.

2020 Modelled Year Return Period (2024 shifted Return Period) 1 in X – Defended Sustain Standard of Service	5 (4)	10 (8)	20 (17)	30 (25)	200 (163)	1000 (737)
Residential	-	3	2	6	10	59
Non-Residential	15	17	23	24	35	78

Table 2.6. 2020 Property Count Flooded Above Threshold – Shaldon.

2020 Modelled Year Return Period (2024 shifted Return Period) 1 in X – Defended Sustain Standard of Service	5 (4)	10 (8)	20 (17)	30 (25)	200 (163)	1000 (737)
Residential	-	4	5	5	5	7
Non-Residential	-	-	-	-	-	-

2.1.1 Limitations of assessment

The assessment used a proportionate approach given the initial stage of the appraisal. Limitations on the approach and suggested improvements are listed below:

- The current assessment made use of readily available data. A range of climate change epochs should be included for all options at appraisal stage.
- Buildings are modelled with 300mm stubby footprints. This means damages will be underestimated as this is both above the recommended building threshold level for economics and means there will be no

below floor level flooding. Any new modelling for economics should use 'increased model roughness' instead of stubs.

- Assets included in this assessment may also be at risk of fluvial/surface water flooding. Benefits may require to be apportioned to other schemes during the considered benefit period. This could considerably reduce the benefits.
- The railway is outside the benefit area and so has not been included. Tourism and recreation losses would largely transfer to other UK designations and would not represent a significant national loss. These are therefore not assessed at this initial stage.
- Finally, it is also crucial to understand what proportions (if any) of the existing benefits (and residential property counts) may have already been claimed for construction/capital works on the existing defences. The current exercise did not attempt to quantify the proportion of available benefits for the proposed works. This is important for partnership funding. Double counting of benefits has not been considered at this stage but it is recommended that this is considered at the next stage.

3. Conclusions

3.1 Do-nothing damages for use in BMP appraisal

Based on the new assessment, Present Value Do-nothing damages for the BMP frontage can be summarised as follows:

- Present Value damages for Teignmouth: **£126.1 million**.
 - Adjusting the threshold by +/- 0.3m this could range from £89.9 million to £146.5 million.
- Present Value damages for Shaldon: **£3.2 million**.
 - Adjusting the threshold by +/- 0.3m this could range from £2.1 million to £3.9 million.

Potential OM2's are negligible based on there being existing defences. Teignmouth defences are expected to fail around year five, and Shaldon around year 25. However, it should be noted that the property counts in Table 2.5 and Table 2.6 are based on modelling which incorporates 300mm high building polygons and so will be an underestimate of the numbers with floodwater passing threshold (typically 150mm doorstep for residential buildings). Furthermore, if it is assumed that failure of defences occurs in year 0 rather than year 5 then approximately 130 OM2A's could be claimed at Teignmouth. This is based on 140 properties at risk in a 1 in 163 year event (approximately 1 in 200) at 2030 under a do nothing option and 10 under a sustain standard of service option (where defence heights remain as they are).

3.2 Sustain damages for use in BMP appraisal

The Present Value sustain damages for the BMP frontage can be summarised as follows:

- Present Value damages for Teignmouth: **£53.3 million**.
 - Adjusting the threshold by +/- 0.3m this could range from £25.7 million to £66.6 million.
- Present Value damages for Shaldon: **£2.7 million**.
 - Adjusting the threshold by +/- 0.3m this could range from £2.0 million to £3.3 million.

3.2.1 Recommendations for further assessment

It is recommended that we obtain an understanding if any of the assets are also at risk from fluvial/surface water flooding and require sharing with other schemes.

Further modelling is needed to include climate change epochs, and the removal of the large 300mm stubby building footprints (replace with building footprint increased roughness).

3.3 Potential beneficiaries

Further examination of which non-residential properties remain at risk may suggest potential beneficiaries.

It is most likely partnership funding efforts should focus on seeking contributions from the Environment Agency, Teignbridge District Council, and Devon County Council in the first instance.

There is an ongoing review of the Environment Agency funding criteria, and a public consultation on this is expected very soon. It is expected that the funding allocation mechanism and amounts will be changing significantly.

Appendix E. Issues, Current Management Practices and Actions

Issues, Current Management Practices and Actions

Date: 1 October 2025
Project name: Teignmouth BMP
Project no: B2471100
Prepared by: Emma Allan / Jack Eade
Document no: 1
Revision no: P01

Aperture @ Pynes Hill, Rydon Lane
Exeter, EX2 5AZ
United Kingdom
T +44 (0)139 226 9800
www.jacobs.com

1. Introduction

There are a number of issues related to Flood and Coastal Erosion Risk Management (FCERM) within the BMP study area, which extends from The Ness, Shaldon; the Teign Estuary as far as Shaldon Bridge, and Back Beach/The Point to The Parson and Clerk headland to the north (see Figure 1.1). It excludes Holcombe beach from the eastern extent of Teignmouth seafront beach to Parsons Tunnel. However, as requested by the Client, the future management extent only extended into the estuary as far as Clipper Quay and north as far as East Cliff. Some of the issues are already addressed by existing management practices, be it in part of fully. However, in some instances these issues are only addressed in part or not addressed at all.

The aim of the BMP is to guide coastal flood and erosion risk management activities in the next 20-30 years, and from that, define the management regime for the next 5 years. This will be done in the context of the longer-term (100 years) sustainable and integrated plan to implement the SMP2 policy for the study area.

As part of the BMP process, it is therefore important to identify the existing FCERM issues, determine how they are addressed at present, and identify the actions that can be taken to resolve these issues.

With that, this document provides:

1. A summary of the FCERM issues in the BMP study area.
2. A description of the current management practices that either in part or fully address the issue.
3. The actions that will be taken as part of the BMP development to address the issue.

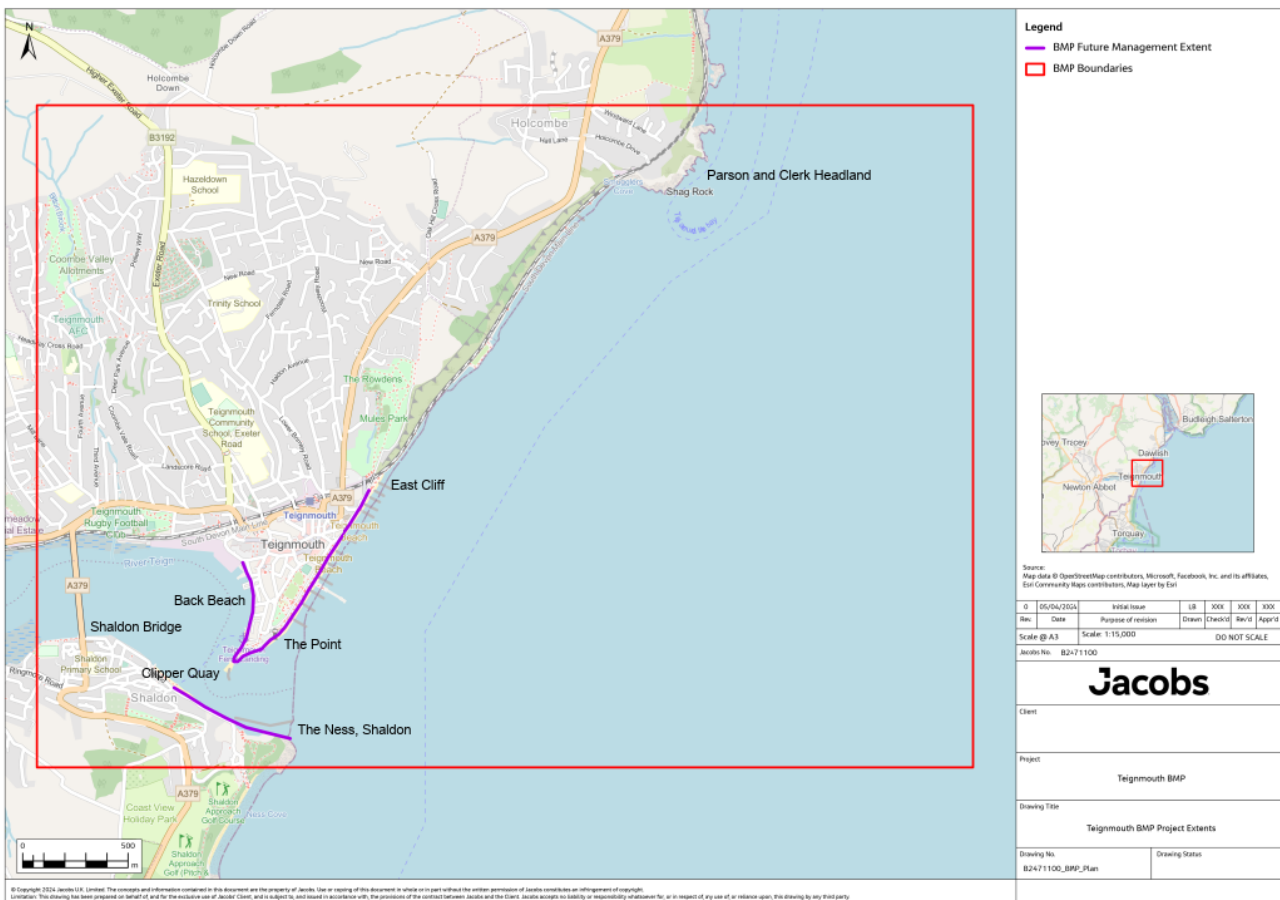

Figure 1.1 The study area (red outline) and BMP frontage (purple line).

2. Sources of Information

The issues have been identified from a number of sources, including:

- The original project scope.
- Pre project start-up call – 18th January 2024.
- Client start up meeting – 24th January 2024.
- Site visit – 24th January 2024.
- Stakeholder meeting 1 – 22nd July 2024.
- Stakeholder meeting 2 – 15th October 2024.
- Binnies, 2024 – Teignmouth Coastal Defences Engineering Assessment.
- Environment Agency, 2023 – Teignmouth Sea Defence Scheme Remedial Works Reporting.
- Baseline studies completed for the current BMP, including:
 - Coastal Processes Baseline Report;
 - Defences Baseline Report;
 - Environmental Baseline Report; and
 - Economics Baseline Report.

3. Summary of FCERM Issues, Current Management Practices and Actions to be Taken by the BMP

3.1 BMP Wide Issues

W	FCERM Issue	Description of Issue and Associated Concerns	Where Identified	Current Management Practice	Action to Take Forward in BMP
W.1	Teignmouth BMP (2014)	The existing BMP sets out management policy and intention for FCERM of the BMP extent.	Client start up meeting – 24th January 2024	n/a	Action: consider within long-list options appraisal: <ul style="list-style-type: none"> ▪ Current BMP options, management practices and trigger levels for suitability and use in the current BMP.
W.1	Dredging operations and placement	At the time of writing this note the current MMO licence was due to expire in December 2024. Teignmouth Harbour Commissioner were in the process of applying for a new licence. This has since been approved.	Client start up meeting – 24th January 2024 Coastal Processes Baseline Report Environmental Baseline Report	Teignmouth Harbour Commissioner currently undertake all dredging operations. <ul style="list-style-type: none"> ▪ Plough dredging is undertaken three days a week on both ebb and flow tides – quantities not known. ▪ Grab dredging occurs a few times a year, when material is taken from the estuary channel and deposited at the west side of Sprey Point. 	Action: consider within long-list options appraisal: <ul style="list-style-type: none"> ▪ The suitability of the dredge disposal site using the findings of the Coastal Processes Baseline Report. ▪ If a new receiving site is identified, this will require: <ul style="list-style-type: none"> - Scientific evaluation (as described in Section 5.2.3 of the Environmental Baseline Report) - Consultation (including statutory consultees such as Natural England, English Heritage, Devon County Council, TDC and the EA).

W	FCERM Issue	Description of Issue and Associated Concerns	Where Identified	Current Management Practice	Action to Take Forward in BMP
					<ul style="list-style-type: none"> If relevant, the BMP to make recommendations for evaluation and MMO licence variation.
W.2	Dredging – transport of disposed dredged material	<p>The impact of plough dredging on sediment budget/shoreline change is not fully understood.</p> <p>Analysis completed for the current BMP, found that removal of the full licensed volume of dredge material from the estuary mouth and its associated placement at Sprey Point could lead to a potential loss of material from the Teignmouth sediment cell.</p>	<p>Client start up meeting – 24th January 2024.</p> <p>Coastal Processes Baseline Report</p>	n/a	<p>Action: consider within long-list options appraisal:</p> <ul style="list-style-type: none"> Assume a net zero loss of material as a result of plough dredging as the material is moved into suspension and then carried by the ebb/flood tide. Following on from W.2 above, consider placement of dredge material at a location where the material is more likely to be retained within the system.
W.3	Dredge material - size and content	<p>Sediment sampling completed for 2014 BMP. Dredged material is pea sized gravel and very clean, but not sand-sized. This material may not be suitable for placement on the sandy beach.</p>	<p>Stakeholder meeting 1 – 22nd July 2024</p> <p>Environmental Baseline Report</p>	<p>Sediment analysis indicated a D50 range of sediment grain size as being between 0.2mm and 5mm. No chemical analysis of the samples was undertaken. These samples were taken from the navigation channel and nearshore area and not the beaches along the foreshore.</p>	<p>Action: consider within longlist options appraisal:</p> <ul style="list-style-type: none"> Consider suitability of dredge material for recharge.

W	FCERM Issue	Description of Issue and Associated Concerns	Where Identified	Current Management Practice	Action to Take Forward in BMP
W.4	Environment Agency - remedial works project currently underway	The preferred options for remedial works needs to be informed by the current BMP.	Stakeholder meeting 1 – 22 nd July 2024	n/a	Action: consider within long-list options appraisal and recommendations: <ul style="list-style-type: none"> ▪ BMP to inform the remedial works project and provide more granularity on options relating to the seawall and beach management.
W.5	Movement of beach material during storms	Understanding of the sediment movement between the beach, nearshore and offshore is limited.	Coastal Processes Baseline Report	An improved understanding of the coastal processes along the BMP frontage has been completed as part of the Coastal Processes Baseline produced for the current BMP.	Action: consider within long-list options appraisal.
W.6	Dawlish Warren Scheme – utilise lessons learned	Good to give regional context with public engagement discussing Dawlish/Exmouth/historical behaviour at Teignmouth.	Client start up meeting – 24th January 2024	n/a	Action: consider within long-list options appraisal and recommendations.
W.7	Requirement for HRA	Early consultation with Natural England during the development of the BMP will be required. There is a potential requirement for a Habitats Regulations Assessment to assess impacts of beach management activities on the integrity of international nature conservation sites. There is also a potential requirement for a Marine Conservation Zone assessment.	Environmental Baseline Report	n/a	Action: Consider within long-list options appraisal. As part of options appraisal, need for HRA screening will be considered and taken forward if required on the final selected preferred option, in discussion with Natural England and East District Council.

3.2 Shaldon

S	FCERM Issue	Description of Issue and Associated Concerns	Where Identified	Current Management Practice	Action to Take Forward in BMP
S.1	Teign Estuary training wall – influence on FCERM	On the southern side of the Teign Estuary, extending from Marine Parade, is a low level training wall that sits at 'half-tide' height. Its purpose is to arrow the tidal channel, funnel tidal flow away from the shoreline and protect from shoreline erosion/scour, but aid scour within the channel so that is deeper (thereby aiding navigation).	Project scope Client start up meeting – 24th January 2024	n/a	Action: within long-list options appraisal, consideration could be given to the benefit that the training wall provides as it helps to prevent shoreline erosion via scour that would otherwise occur along the shoreline at The Ness.
S.2	Shaldon – defence condition	The defences were assessed to be in good or fair for condition, with a residual life of 22-80 years, structure depending. Due to data availability, it was not possible to complete an assessment of tidal flooding at Shaldon.	Defences Baseline Report	See S.3 below.	Action: within the options appraisal, consider if the 1:300 SoP will be maintained and if so for how long.
S.3	Shaldon and Ringmore Flood Defence Scheme (2011) – inclusion of The Point breakwater	The Point breakwater could provide flood risk benefit to the Teign Estuary (by reducing waves heights/water levels). It is unknown if the breakwater was included in the 2011 scheme, and if it acts to reduce wave heights and water levels presently.	Pre project start-up call – 18th January 2024	The scheme included the design and construction of raised flood defences along 1.7 km of the existing walls, incorporating 10 flood gates, 25 flood windows and doors, access steps, ramps and a pump station with outfall to	Action: within the options appraisal, the BMP will need to consider the flood risk benefit that The Point breakwater Shaldon – i.e. if it is acting to hold the spit in place (and thereby providing some form of break to waves and water levels).

S	FCERM Issue	Description of Issue and Associated Concerns	Where Identified	Current Management Practice	Action to Take Forward in BMP
				<p>alleviate the current surface water issues.</p> <p>It was designed to provide a 1 in 300 year standard of protection for 453 homes and businesses in Shaldon and Ringmore.</p> <p>The Point breakwater is owned and maintained by Teignmouth Harbour Commission.</p>	<p>Additional assessment may be required as part of the coastal processes baseline being completed for the BMP, along with any impacts on the economics assessment/ options development.</p>
S.4	Shaldon - beach level increase/ lowering	<p>Between 2011 and 2022, there has been a significant increase in beach elevation at the western end of Shaldon Beach on the inside of the estuary, and a significant decrease in elevation at the eastern end just outside the estuary mouth.</p> <p>Sea level rise is anticipated to exacerbate beach lowering/narrowing, with the potential for submergence of the beach at the southern end of Teignmouth seafront.</p>	Coastal Processes Baseline Report	Recycling	<p>Action: within the options appraisal, consider management techniques to address beach increase/lowering (e.g. recycling), and potential submergence due to sea level rise.</p>
S.5	Beach monitoring – limited extent	<p>There is limited beach profile data on the most exposed section of Shaldon seawall. This limits the assessment that can be made of</p>	Defences Baseline Report	<p>Beach monitoring undertaken through the South West Regional Coastal Monitoring Programme (SWCRMP).</p>	<p>Action: include a recommendation in the BMP Action Plan for more profiles between 6b00258 and 6b00263 to be surveyed</p>

S	FCERM Issue	Description of Issue and Associated Concerns	Where Identified	Current Management Practice	Action to Take Forward in BMP
		overtopping and undermining risk of the wall.			regularly. Survey data to be used alongside analysis of LiDAR data.

3.3 Back Beach

BB	FCERM Issue	Description of Issue and Associated Concerns	Where Identified	Current Management Practice	Action to Take Forward in BMP
BB.1	Back Beach – defence condition	The defences were assessed to be in good or fair for condition, with a residual life of 22-80 years, structure depending. The assessment of tidal flooding completed for the current BMP concludes that there a number of structures, flood gates and elements of the properties improvements that are no longer providing the 'as designed' 1:1000 SoP.	Defences Baseline Report (Sections 3.5, 5.2 and 5.3)	See BB.2 below.	Action: within the options appraisal, consider if the 1:1000 SoP will be maintained and if so for how long.
BB.2	Teignmouth (Back Beach) Tidal Defence Scheme (2011-2012) – inclusion of The Point breakwater	The Point breakwater could provide flood risk benefit to the Teign Estuary (by reducing waves heights/water levels). It is unknown if the breakwater was included in the 2011-2012 scheme and if it acts to reduce	Pre_Start_Up Initial Call 18_01_24	The scheme included construction of new flood walls, flood gates, property and road/slipway improvements and demountables. The Point breakwater is owned and maintained by Teignmouth Harbour Commission.	Action: within the options appraisal, the BMP will need to consider the flood risk benefit that The Point breakwater affords Back Beach – i.e. if it is acting to hold the spit in place (and thereby providing some form of break to waves and water levels).

BB	FCERM Issue	Description of Issue and Associated Concerns	Where Identified	Current Management Practice	Action to Take Forward in BMP
		wave heights and water levels presently.		It was designed to provide a 1 in 1000 year (0.1%) standard of protection. The Point breakwater is owned and maintained by Teignmouth Harbour Commission.	Additional assessment may be required as part of the coastal processes baseline being completed for the BMP, along with any impacts on the economics assessment/ options development.
BB.2	Back Beach (The Point) – recycling	In 2014, 10,000m ³ of material was moved from the back of spit, to the beach in front of lighthouse. The sediment disappeared quickly following storms.	Stakeholder meeting 1 – 22 nd July 2024		Action: within the options appraisal, include recycling as an option, but consider the pros and cons utilising the observations of loss made, alongside the findings of the Coastal Processes Report.
BB.3	Back Beach (The Point) - beach level increasing	Since 2007, Teignmouth Back Beach has remained relatively stable. Beach levels on the estuary side of The Point, have increased between 2007 and 2022, thought to be sourced by storm induced overwash of sediment from the Seafront Beach.	Project scope Coastal Processes Baseline Report	n/a	Action: within the options appraisal, consider potential or recycling of material across The Point from areas of volume increase to volume decrease. Noting BB.2 above when this was trialled in 2014 and the material did not stay in place.
BB.4	Back Beach (between Lower Point Car Park - Morgans Quay-Fish Quay)	The beach between Lower Point Car Park and Morgans Quay has lost ~4 m ³ /m since 2007, and the beach between Morgans Quay and Fish Quay has gained ~7 m ³ /m.	Coastal Processes Baseline Report	n/a	Action: within the options appraisal consider overall health of beach and if there is a need and potential for beach

BB	FCERM Issue	Description of Issue and Associated Concerns	Where Identified	Current Management Practice	Action to Take Forward in BMP
					recharge/recycling along Back Beach.
BB.5	Beach monitoring – limited extent on seaward extent of The Point	There is limited beach profile data/analysis on the seaward/central section of The Point. This would help to inform the hypothesis that material is being moved from the seaward to landward edge of the spit via overwash.	Defences Baseline Report	Beach monitoring undertaken through the South West Regional Coastal Monitoring Programme (SWCRMP).	Action: include a recommendation in the BMP Action Plan to add/survey more regularly a beach profile to seaward face of The Point to monitor change. Survey data to be used alongside analysis of LiDAR data.

3.4 Teignmouth Seafront, including the Point Breakwater

TS	FCERM Issue	Description of Issue and Associated Concerns	Where Identified	Current Management Practice	Action to Take Forward in BMP
TS.1	The Point breakwater – ownership/management	The Point breakwater is owned and maintained by Teignmouth Harbour Commission.	Stakeholder Engagement Meeting 1 22_07_24	The Point breakwater is owned and maintained by Teignmouth Harbour Commission.	No action: Future maintenance of the breakwater will be determined by its function (see item below).
TS.2	The Point breakwater – function	It is unclear as to whether the breakwater has FCERM function. <ul style="list-style-type: none"> ▪ Does it stabilise the spit? ▪ Does it reduce water levels in the estuary? ▪ Does it reduce wave action at back beach? 	Pre_Start_Up Initial Call 18_01_24 Client start up meeting – 24th January 2024	n/a	Action: BMP to assess what would happen if the training wall failed. Investigate as part of the coastal processes baseline work with additional modelling to understand its function and use this in the options development.

TS	FCERM Issue	Description of Issue and Associated Concerns	Where Identified	Current Management Practice	Action to Take Forward in BMP
TS.3	The Point breakwater – Shoreline Management Plan Policy	Issue with how addressed in SMP. BMP may need to recommend different policy once know function.	Stakeholder meeting 1 – 22 nd July 2024	n/a	Action: within the options appraisal, consider SMP policy for the breakwater and if relevant make recommendations for change within the BMP Action Plan.
TS.4	The Point breakwater – condition	The asset inspection completed for the current BMP found the breakwater to be in fair condition with a residual life of 20 years.	Client start up meeting – 24th January 2024 Defences Baseline Report	See item TS.1 above.	Action: within the options appraisal, consider options for maintenance of the breakwater and function (as outlined in TS.2 above).
TS.4	Teignmouth Seawall – ownership	Responsibilities for Teignmouth seawall varies along its length.	Client start up meeting – 24th January 2024.	Current responsibilities: <ul style="list-style-type: none"> ▪ TDC - The Point up the lighthouse ▪ EA - The Point ramp to The Pier ▪ TDC - East Cliff wall, groynes and outfall ▪ EA – seaward of recurve wall ▪ Privately owned – The Pier (including footprint) ▪ Network Rail – seawall north of East Cliff 	Action: BMP to consider ownership when preparing economics and considering funding options.
TS.5	Teignmouth seawall – condition	In places, the seawall is in poor condition, elsewhere ranging from fair to good, with a residual life of	Project scope Pre_Start_Up Initial Call 18_01_24	The current management practice is to maintain the seawall.	Action: within the options appraisal, consider suitable options for the seawall, and seek

TS	FCERM Issue	Description of Issue and Associated Concerns	Where Identified	Current Management Practice	Action to Take Forward in BMP
		20-30 years. Various issues along its length and provision of a Standard of Protection between 1:50 to 1:500 location depending, as set out in the Defences Baseline Report.	Client start up meeting – 24th January 2024 Stakeholder meeting 1 – 22 nd July 2024 Defences Baseline Report Environment Agency, 2023 – Teignmouth Sea Defence Scheme Remedial Works Reporting.	The EA have recently commissioned Binnie’s to assess condition of seawall. <ul style="list-style-type: none"> There are now sensors in place. Monthly reports produced, including an assessment of the Factor of Safety (FoS) of the seawall. 	to provide a consistent Standard of Protection along the length of the seawall.
TS.6	Groynes – poor condition	The groynes along the length of Teignmouth seafront have failed or are failing. The asset inspection completed for the current BMP graded the condition of the groynes as poor with a residual life of 2 years. This is exacerbated by beach lowering.	Client start up meeting – 24th January 2024 Stakeholder meeting 1 – 22 nd July 2024 Defences Baseline Report Environment Agency, 2023 – Teignmouth Sea Defence Scheme Remedial Works Reporting.	Maintained to a reasonable standard of care for public safety.	Action: within the options appraisal, include options for groynes, such as; <ul style="list-style-type: none"> Material, e.g. timber or rock Groyne length Groyne spacing Access – tied to the seawall, up and overs, HSE Complete removal.
TS.7	Outfalls	The South West Water outfall acts as a groyne and is currently buried. No flaps on outfalls.	Client start up meeting – 24th January 2024	n/a	Action: BMP to include recommendation to add flaps to outfalls as part of options development for the seawall. Also, BMP to consider suitable option for where the northern outfall at East Cliff is acting as a groyne and retaining sediment –

TS	FCERM Issue	Description of Issue and Associated Concerns	Where Identified	Current Management Practice	Action to Take Forward in BMP
					possible construction of a new groyne at location of the outfall.
TS.8	Beach levels – lowering/volatile/volume loss	<p>The beach to the north is accreting; however, to the south from the Pavilions, beach levels are lowering and there is an overall trend of beach volume loss. This loss has occurred even while the groynes functional, so it is assumed that sediment beach material is being drawn offshore, before being transported alongshore and bypassing the groynes.</p> <ul style="list-style-type: none"> ▪ In 1992, rapid beach loss occurred. ▪ Between Teignmouth Lighthouse and Teignmouth Pier, beach levels are ~3m lower in 2024 than they were in 2007. ▪ In 2023, storms Babet and Ciarán lead to beach lowering. 	<p>Project scope Client start up meeting – 24th January 2024 Coastal Processes Baseline</p>	No current management of the beach between The Point and East Cliff.	<p>Action: BMP to consider within options appraisal:</p> <ul style="list-style-type: none"> ▪ Construction of a new terminal groyne at Teignmouth Lighthouse. ▪ Recycling of beach material from areas of accretion to areas of erosion. ▪ Consider lengthening the groynes to retain material on the beach and prevent sediment bypassing. <p>Removal of groynes, combined with new seawall toe protection (to prevent undermining in event beach is no longer retained).</p>
TS.9	East Cliff - exposed bedrock	The bedrock does get exposed at East Clif.	Client start up meeting – 24th January 2024.	n/a	Action: within the options appraisal, consider management techniques to address beach lowering.

TS	FCERM Issue	Description of Issue and Associated Concerns	Where Identified	Current Management Practice	Action to Take Forward in BMP
TS.10	Sediment transport	<p>Teignmouth is not a closed sediment cell, with material being transported around the bounding headlands beyond the theoretical Depth of Closure.</p> <p>A strong increase in the net south to north flux along the shoreline between Teignmouth Lighthouse and Teignmouth Pier.</p> <p>A 75% reduction in energetic wave conditions arriving from the east, which otherwise act to renourish the beach where material is moved from south to north as described above.</p> <p>A drift divide, previously thought to exist at Sprey Point, potentially now exists close to Teignmouth Lighthouse.</p> <p>As per W.2 and W.3 item above, dredging operations impact the overall sediment budget along this coastline.</p> <p>Sea level rise is anticipated to exacerbate beach lowering/narrowing, with the potential for submergence of the beach at the</p>	Coastal Processes Baseline	n/a	<p>Action: within the options appraisal, consider closure depth, sediment transport patterns, drift divide location and impacts of sea level rise/coastal squeeze when looking at any beach recharge/recycling options.</p>

Technical Memorandum

TS	FCERM Issue	Description of Issue and Associated Concerns	Where Identified	Current Management Practice	Action to Take Forward in BMP
		southern end of Teignmouth seafront.			
TS.11	Historic shipwreck at Sprey point	-	Client start up meeting – 24th January 2024	n/a	Action: No action for BMP, but should be considered when implementing preferred option.
TS.12	Unexploded Ordnance (UXO)	During World War 2 the beach was heavily defended with artillery batteries, beach scaffolding and likely a minefield. An unexplored bomb discovered near pier 5-6 years ago. There is potential that unearthed UXO may exist in the area, which would be a risk to beach management activities.	Client start up meeting – 24th January 2024 Environment Agency, 2023 – Teignmouth Sea Defence Scheme Remedial Works Reporting	n/a	Action: No action for BMP, but should be considered when implementing preferred option.

Appendix F. Options Appraisal Report

Options Appraisal Report

Document no: 1

Revision: 3

Teignbridge Council

Teignmouth Beach Management Plan

12 November 2025

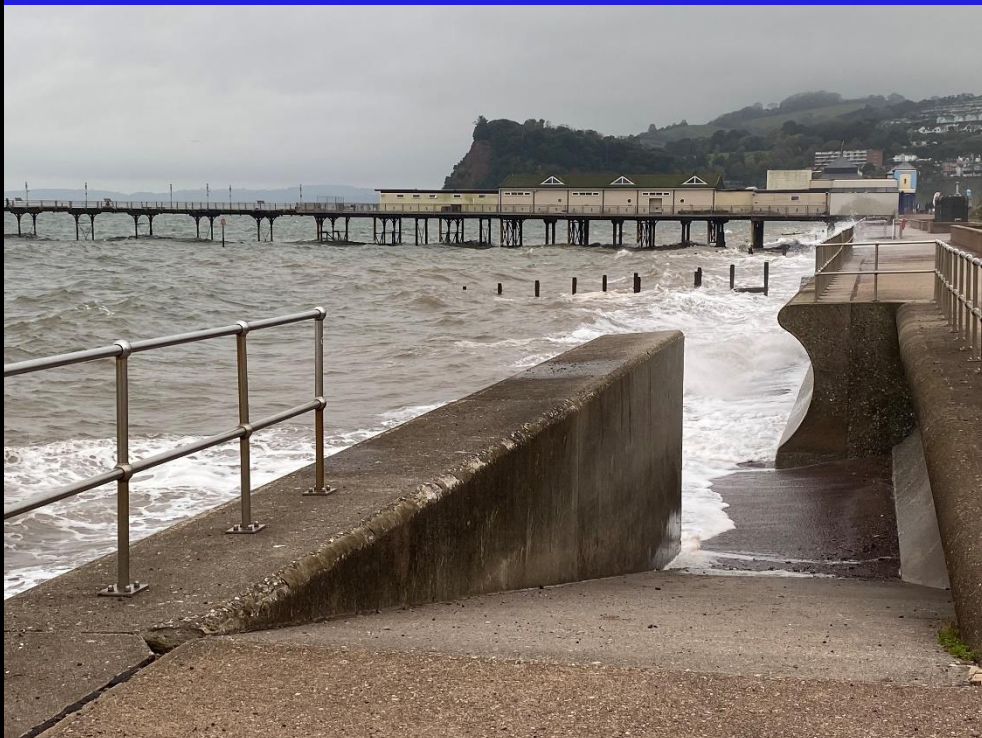

Options Appraisal Report

Client name: Teignbridge Council
Project name: Teignmouth Beach Management Plan
Client reference: n/a
Document no: 1
Revision: 3
Date: 12 November 2025

Project no: B2471100
Project manager: Emma Allan
Prepared by: Emma Allan
File name: Teignmouth and Shaldon
BMP_Options Appraisal
Report_Final_rev 1

Document status: Final

Document history and status

Revision	Date	Description	Author	Checked	Reviewed	Approved
1	04.09.25	Draft for Client Review	EA	JE	LOT	EA
2	02.10.25	Final for Client	EA	JE	LOT	EA
3	12.11.25	Final for Client	EA	JE	LOT	EA

Distribution of copies

Revision	Issue approved	Date issued	Issued to	Comments
2	14.10.25	14.10.25	TDC	Final for Client
3	12.11.25	12.11.25	TDC	Minor amendments following Client comment on Main BMP document.

Jacobs U.K. Limited

Aperture @ Pynes Hill, Rydon Lane
Exeter, EX2 5AZ
United Kingdom

T +44 (0)139 226 9800
www.jacobs.com

© Copyright 2025 Jacobs U.K. Limited. All rights reserved. The content and information contained in this document are the property of the Jacobs group of companies ("Jacobs Group"). Publication, distribution, or reproduction of this document in whole or in part without the written permission of Jacobs Group constitutes an infringement of copyright. Jacobs, the Jacobs logo, and all other Jacobs Group trademarks are the property of Jacobs Group.

NOTICE: This document has been prepared exclusively for the use and benefit of Jacobs Group client. Jacobs Group accepts no liability or responsibility for any use or reliance upon this document by any third party.

Contents

1. Introduction	5
1.1 BMP area and background	5
1.2 Options appraisal overview	6
1.3 Teignmouth sea defence scheme remedial works	7
1.4 Report structure	9
2. Longlist Measures Appraisal	10
2.1 Longlist appraisal approach	10
2.1.1 Step 1 - Flood and coastal erosion risk	10
2.1.2 Step 2 - Derivation of the longlist	10
2.1.3 Step 3 – Longlist Appraisal	11
2.1.4 Beneficial use of material	11
2.1.5 The Point breakwater modelling	12
3. Shortlist Appraisal	17
3.1 Shortlist appraisal approach	17
3.1.1 Options cost assessment of the costs and benefits	17
3.1.2 Shortlist options modelling	17
3.1.3 Option modelling results	18
3.2 Shortlist of measures & options	18
3.3 Teignmouth Remedial Works Strategic Outline Business Case	25
4. Preferred Option Selection	27
4.1 Preferred Option	27
5. References	28

Appendices

Appendices	29
Appendix A Longlist Appraisal	30
Appendix B Shortlist Appraisal	31
Appendix C Shortlist Cost Assessment	32
Appendix D Model findings synopsis	33
Model findings synopsis	34
D.1 Baseline model conditions	34
D.2 The Point breakwater modelling	34
D.3 Shortlist options modelling	35
D.3.1 Option modelling results	36
D.3.2 With groynes scenario	36
D.3.3 Options modelling conclusions	38

D.3.4 Recommendations for further modelling	38
---	----

Tables

Table 1.1 FCERM generic options adopted for the BMP options appraisal.	7
Table 1.2 Strategic Outline Business Case shortlisted options (Environment Agency, 2025).	9
Table 2.1 Teignmouth BMP longlist – measures shortlisted for further appraisal	13
Table 3.1 Calculated beach volume loss along the Teignmouth open coast (14 May 2018 to 12 February 2020).	18
Table 3.2 Longlist and shortlist measure numbers	18
Table 3.3 Teignmouth BMP shortlist options – Option 1 – Sustain SOS – falling SOP over time.....	20
Table 3.8 Shortlisted options for the BMP and Teignmouth Remedial Works Strategic Outline Business Case.	25
Table D 1 Calculated beach volume loss along the Teignmouth open coast (14 May 2018 to 12 February 2020).	38
Table D 2 Proposed model runs.	39

Figures

Figure 1-1 The study area (red outline) and BMP frontage (purple line).....	5
Figure 1-2 BMP development process.	5
Figure 1-3 Options appraisal process – staged approach to option selection.....	6
Figure 1-4 Teignmouth sea defence scheme remedial works study area (source: Environment Agency, 2025).	8
Figure 2-1 Image showing location of The Point breakwater.....	12
Figure D 1 Left (c) bed levels after reinstatement of groynes; and right (e) bed level change from baseline (i.e. no groynes) and after-reinstatement of groynes with area of shorter groynes shown by the red circle. Refer to Figure 9-5 of Appendix C to the BMP for the original image.	37
Figure D 2 Bed level change from baseline (i.e. no groynes) and after-reinstatement of groynes + relocated dredged material disposal site.....	37

1. Introduction

1.1 BMP area and background

This report presents the findings of the option appraisal completed for the Teignmouth Beach Management Plan (BMP) to identify and appraise a range of options for the BMP frontage to help manage flood and coastal erosion risks over the next 100 years. The BMP boundary extends from The Ness, Shaldon; the Teign Estuary as far as Shaldon Bridge, and Back Beach/The Point to The Parson and Clerk headland to the North (see Figure 1-1). However, as requested by the Client, the future management extent (and therefore the options appraisal) only extended into the estuary as far as Clipper Quay and north as far as East Cliff.

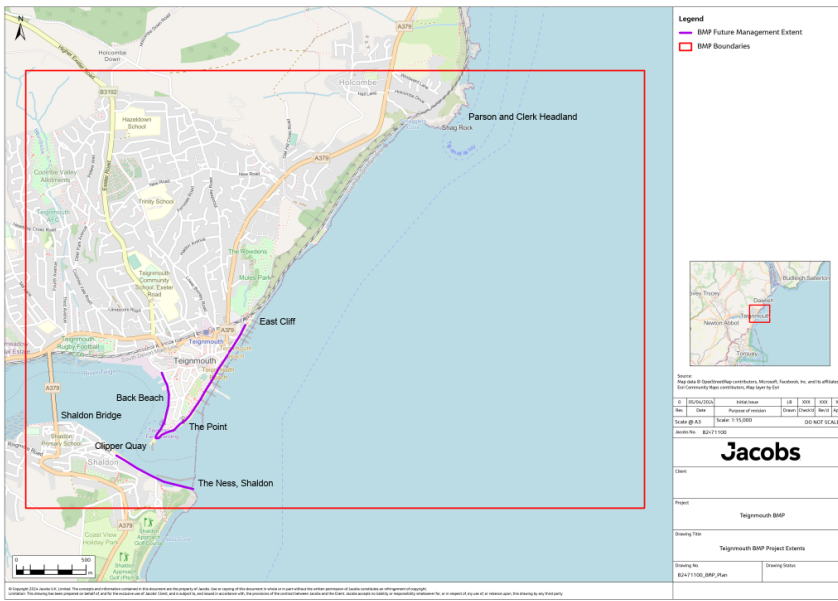

Figure 1-1 The study area (red outline) and BMP frontage (purple line).

The report is a supporting document to the BMP and covers Stage 5 of the BMP development process (as shown in Figure 1-2) and discussed in more detail in the BMP document (Jacobs, 2025). The appraisal has been completed in accordance with best practice guidance and followed a staged approach to ensure that the decision making process was transparent and auditable.

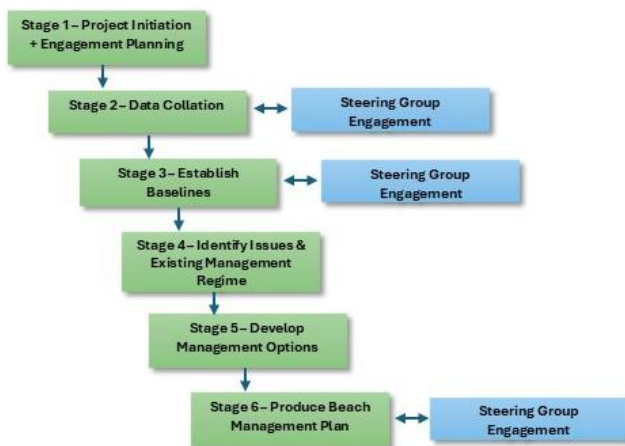

Figure 1-2 BMP development process.

1.2 Options appraisal overview

The options appraisal approach adopted for the BMP follows the Environment Agency's Flood and Coastal Erosion Risk Management Appraisal Guidance (FCERM-AG) (Environment Agency, 2024). The level of detail within the appraisal is appropriate to meet the BMP objectives, with the view that the BMP outcomes will be used to steer the future FCERM direction and investment for the BMP frontage.

The selection of a preferred option / management approach for the BMP frontage was undertaken via a staged approach (shown in Figure 1-3), where a longlist of measures was rationalised to a shortlist of measures, and from there grouped into a shortlist of options and ultimately a preferred option selected to provide an integrated, sustainable, long-term (100 year) management solution for the BMP frontage.



Figure 1-3 Options appraisal process – staged approach to option selection.

The defences along the BMP frontage consists of a mixture of flood and erosion function, standards of service and protection, and are located around the estuary mouth with different damage/benefit areas. For this reason, the options appraisal for this BMP has been particularly intricate.

The BMP frontage was first divided into four discrete sections based on where they were geographically located within the BMP study area, and for each section, all possible management approaches set-out as a longlist of measures. Each longlist measure was assigned a reference 'measure number' for ease of tracking and auditability through the appraisal process (TOC1, TP1, etc), and then aligned to the relevant generic FCERM option and description (see Table 1.1). The means by which that measure could be implemented was identified. The study area sections with measure numbers are:

1. Teignmouth Open Coast (TOC1-TOC19);
2. The Point (TP1-TP9);
3. Teignmouth Back Beach (TBB1-TBB13); and
4. Shaldon (S1-S11).

The relevant FCERM options include:

- Standard of Service (SoS) – refers to the physical dimensions, integrity and resilience of a structure designed to provide protection against flooding and coastal erosion to a Standard of Protection (see below).
- Design Life (DL) – the length of time that the structure is designed to remain operational (allowing for a design criteria set at the design stage).
- Standard of Protection (SoP) – the conditions for which a structure is designed to withstand including namely water levels, waves and sea level rise.

A combination of the baseline studies (completed specifically for the BMP as part of Stage 3), the Issues, Current Management Practices and Actions report (Stage 4) and other supporting discussions and documentation, as listed in Section 2.1.2, were used to derive the longlist of measures.

Teignmouth District Council commissioned a series of modelling studies specifically for the current BMP to support the longlist and shortlist appraisal respectively. The full model studies are presented in the Coastal Processes Baseline Report (refer to Appendix A to the BMP), with key findings and interpretation presented within this report for reference; (i) modelling of The Point breakwater (see Section 2.1.4); and (ii) modelling of a select number of measures to support the shortlist appraisal (see Section 3.1.2).

In accordance with the FCERM-AG, each longlist measure was then appraised technically, economically and environmentally using a combination of the baseline studies and new modelling of the breakwater.

Following rationalisation of the longlist to a shortlist, the measures were further appraised drawing on the new measures modelling and a new assessment of costs and benefits. The rationalised short-list of measures was grouped into a shortlist of options, from which a preferred option was selected. More specific details of the longlist and shortlist appraisal approach are provided in Sections 2.1 and 3.1 respectively.

Table 1.1 FCERM generic options adopted for the BMP options appraisal.

FCERM Generic Option	FCERM Generic Option – Terminology Adopted for Current BMP	FCERM Generic Option Description
1. Do nothing to manage flood or erosion risks	Do Nothing	SoS: not maintained, fails end of RL DL: reduced SoP: gradually decreasing
3. Do minimum to manage flood or erosion risks	Do Minimum	SoS: maintain to end of RL (after which SoS will decrease) DL: as present SoP: gradually decreasing
4. Sustain current SOS	Sustain Current SoS (not keeping pace with SLR)	SoS: sustain for 100 years (replace like with like at end of RL) DL: 100 years SoP: gradually decreasing
5. Options with higher standards of service and same SOP	Improve / Improve A (keeping pace with SLR)	SoS: improve for 100 years DL: 100 years SoP: sustain current for 100 years
6. Options with higher standards of service and higher SOP	Improve B – improving SOP	SoS: improve for 100 years DL: 100 years SoP: improve for 100 years

1.3 Teignmouth sea defence scheme remedial works

At the time of preparing the Teignmouth Beach Management Plan, the Environment Agency are in parallel undertaking the Teignmouth Sea Defence Scheme Remedial Works project. The extent of this project is shown in Figure 1-4, which also forms part of the BMP frontage.

The remedial works project has several objectives, in part, to ensure they align with the Environment Agency's strategic objectives:

- i. Align with the Shoreline Management Policy, which is Hold the Line for the long term (to 2105) (Halcrow, 2011), and in doing so:
 - (a) reduce the risk of flooding to properties and infrastructure, avoid health and safety risks arising from failing or nearly failed defence assets, and wherever possible reduce reliance on emergency works.
 - (b) Identify opportunities to improve the environment and public realm, such as Nature Base Solutions, Biodiversity Net Gain and improved public access and amenity.
- ii. Align to the measures set out in the South West River Basin District Management Plan (Environment Agency 2022). *By 2024 "conduct a study to review existing flood defence schemes*

in Devon, Cornwall and the Isles of Scilly to ascertain their current level of performance, structural stability and whether improvements are required, or whether environmental enhancements could be delivered through changes to their management in the SW River Basin District.”.

- iii. Align to the Local Outcome Plan. *“By 2025 ‘We will focus our efforts on ensuring key assets across flood and environment are reliable and resilient, protecting lives and the environment and reducing flood risk. We will join up asset management and local outcome plans to maximise outcomes for communities”.*
- iv. Align to the South Devon Catchment Plan, in which South Devon is a Focus Area.



Figure 1-4 Teignmouth sea defence scheme remedial works study area (source: Environment Agency, 2025).

The Environment Agency are seeking to complete necessary repair works to rectify structural stability of the seawall and deliver beach management for the length of the remedial works coastline. Work to date includes:

1. **2023/2024 - Sea defence structural investigations** - Teignmouth Coastal Defences Engineering Assessment (Binnies, 2024).
2. **2024/2025 - Project development / project appraisal (including Strategic Outline Case (SOC)** – following internal consultation within the EA, the Teignmouth Coastal Defences Engineering Assessment and the current BMP, the Environment Agency completed the Strategic Outline Business case for the project in 2025. The full shortlist of SOC options are presented in Table 1.2. Next steps to advance the project would include:
 - Outline and Full Business case (OBC/FBC) – detailing a proposed options and cost for the project extent,
 - Design, mobilisation Phase 1 construction (sea defences); and
 - Phase 2 construction (beach management works).

Table 1.2 Strategic Outline Business Case shortlisted options (Environment Agency, 2025).

Option	Shortlist Decision	Technical Risks	Opportunities & Innovation
Do Nothing	Must be shortlisted	Maintenance of fencing, increased flood risk and frequency to community, loss of promenade (erosion of utilities and businesses).	-
Do Minimum Patch repair of failed seawall sections	Must be shortlisted	Reactive repair would lead to regular damages and overall high cost. Would result in inconsistent structure at the end of appraisal period.	-
Do something – 2 Substantial wall stabilisation only	Sustains standard of service	Existing rates of erosion will remain, which will increase with coastal squeeze. Difficult to construct due to deep bedrock, risk of damaging nearby structures.	Working with TDC for public realm enhancements.
Do something – 3 Substantial beach management + no wall stabilisation	Sustains standard of service	Significant increase in beach control structures, which may still not counteract ongoing beach erosion trend. Further nourishment may be required to design life.	Working with TDC for public realm & beach access enhancements.
Do something – 4 Combination solution	Sustains standard of service	As per Do Something 2 & 3. To be explored in technical appraisal of options.	Working with TDC for public realm & beach access enhancements.

At the time of writing the BMP, the leading option is Do something – 4 Combination solution - substantial wall stabilisation and substantial beach management (i.e. beach control structures, with potential renourishment).

1.4 Report structure

This report provides details of the approach taken to prepare the longlist and shortlist for the Teignmouth BMP and the outcomes of the appraisal, including the preferred option selected, and is structured as follows:

- Section 2 – longlist measures appraisal;
- Section 3 – shortlist measures appraisal; and
- Section 4 – preferred option selection.

2. Longlist Measures Appraisal

2.1 Longlist appraisal approach

The purpose of the longlist appraisal is to identify all possible measures to address flood and coastal erosion risk across the BMP frontage, and then assess their viability to derive a shortlist of measures. This section describes the approach taken to derive the longlist and complete the appraisal from long to shortlist.

The full longlist appraisal table is presented in the accompanying spreadsheet, Appendix B (Teignmouth BMP_Longlist_Appraisal_PO1.xlsx), and a summary of the longlist is presented in the following tables:

- Measures shortlisted for further appraisal are listed in Table 2.1.
- Measures filtered out of the appraisal process on grounds of technical, economic or environmental unsuitability are included within Appendix B.

2.1.1 Step 1 - Flood and coastal erosion risk

The first step derived a longlist of measures for further consideration. The measures considered must address flood and coastal erosion risk, which along the Teignmouth BMP coastline are specifically related to:

- Flooding by wave overtopping; and
- Erosion by marine action, cutback and rollback.

2.1.2 Step 2 - Derivation of the longlist

All possible measures have been identified using the information set out below:

- The original project scope.
- Pre project start-up call – 18th January 2024.
- Client start up meeting – 24th January 2024.
- Site visit – 24th January 2024.
- Steering Group meeting 1 – 22nd July 2024.
- Steering Group meeting 2 – 15th October 2024.
- Binnies, 2024 – Teignmouth Coastal Defences Engineering Assessment.
- Environment Agency, 2023a – Teignmouth Sea Defence Scheme Remedial Works Reporting.
- Baseline studies completed for the current BMP:
 - Coastal Processes Baseline: coastal processes, shoreline interactions and shoreline evolution (presented in Appendix A to the BMP).
 - New modelling of The Point Breakwater, summarised in Section 2.1.4 and shortlist option modelling summarised in Section 3.1.2, and both presented in Coastal Processes Baseline (Appendix A to the BMP).
 - Defences Baseline: coastal defence assets, condition and performance (presented in Appendix B to the BMP).
 - Environmental Baseline: environmental setting and features (presented in Appendix C to the BMP).
 - Economics Baseline: economic basis (i.e. the economic benefits) for both ongoing and future beach management and flood and coastal erosion risk management activities (Appendix D to the BMP).

- Issues, Current Management Practices and Actions (Appendix E to the BMP).

2.1.3 Step 3 – Longlist Appraisal

The longlist appraisal assesses the viability of each measure against its technical suitability (considering coastal processes and buildability), the impact that it may have on the environment and potential economic viability (see Sections 2.1.3.1 to 2.1.3.2).

The appraisal outlines the advantages and disadvantages of each measure accordingly, from which it has been determined whether the measure should be taken through to the shortlist.

Any significant '**show-stoppers**' (i.e. significant disadvantages) identified at this early stage have been discounted from the longlist and not considered for further appraisal.

Where a measure may only address the flood and erosion risk in part for a select section of coast, it has been flagged to be considered in conjunction with alternative measures as an '**in-combination**' solution.

2.1.3.1 Technical suitability

Measures were assessed against the impact that it could have on coastal processes and shoreline interaction, and what the measure would entail in terms of construction, maintenance and lifespan of the relevant structure. This appraisal has been informed by the information and evidence of the coastal processes and shoreline interactions presented in the Coastal Processes Baseline Report (refer to Appendix A to the BMP) and coastal asset information presented in the Defence Baseline Report (refer to Appendix B to the BMP).

2.1.3.2 Economic implications

Economic implications of each measure were based on a high-level assessment of affordability based on experience from previous schemes and option type.

2.1.3.3 Environmental impacts

Measures were considered against a standard suite of environmental aspects in order to identify key potential impacts. The appraisal identifies where possible, the positive and negative impacts on different environmental features of different measures. It also attempts to indicate relative differences in environmental impacts between measures; however, this is not always possible at the high level of appraisal that this work is undertaken. Some aspects would only be discernible if a more detailed appraisal were undertaken to develop a particular preferred option or options. This appraisal has been informed by the information and evidence presented in the Environmental Baseline Report (refer to Appendix C to the BMP).

2.1.4 Beneficial use of material

2.1.4.1 Beneficial used of dredge material

The future management regime of the BMP frontage should allow for recycling and placement of material dredged from the estuary approach channel at an alternative disposal location to Sprey Point and is therefore included alongside all longlist measures. As suggested in the Coastal Processes Baseline, material could be better placed on the nearshore of the Teignmouth open coast and would be a cost-effective solution to contribute toward reducing beach lowering there. It is recommended that the material is placed adjacent to the Teignmouth Pier, within the groyne bays immediately to the north or south, where beach levels are particularly low, and is far enough away from the channel that some time passes before it could potentially be transported back to the west and into the channel again. Sediment sampling of the dredge material completed for the recent MMO license application concludes that the sediment is unlikely to be contaminated and would therefore be safe to use.

2.1.4.2 Beneficial use of eroded cliff material

In addition, it is understood that Network Rail undertakes periodic work to remove cliff fall debris from the area between Teignmouth and Sprey Point when it falls onto the railway line. This cliff fall debris is presently removed from site. However, it could more beneficially be placed over the seawall and onto the beach fronting Network Rail's wall. This would add sediment to the coastal system just as it would do if the seawall was not present. Discussions should therefore be held with Network Rail and the Marine Management Organisation to investigate the viability of this activity and the possibility of this change in Network Rail operations being implemented.

2.1.5 The Point breakwater modelling

During the development of the BMP, Teignmouth District Council, the Environment Agency and the BMP Steering Group expressed an interest to better understand the role of The Point breakwater (shown in Figure 2-1) in terms of flood and coastal erosion risk management. To support this, a stand-alone XBeach modelling study of The Point breakwater was undertaken and is included in Appendix E of the Coastal Processes Baseline Report (Appendix A to the BMP). A synopsis and interpretation of the findings is presented in O.

Modelling was completed for four single event scenarios (all of which exclude sea level rise and do not consider potential condition changes to the breakwater); southerly and easterly storms, Storm Ciarán and an extreme storm event (1:100 year event), each with and without the point breakwater in place. The modelling shows concludes:

- The breakwater itself has little impact on water levels and waves height within the estuary. However, it does have an influence on beach elevation during storms, by reducing erosion immediately adjacent to the breakwater, and the accretion of the Point (where eroded beach material could be assumed to be redistributed to) and rollback of the spit into the estuary. The presence of the spit will also act to constrain and maintain the narrow entrance channel at the mouth of the Teign Estuary, thereby reducing wave propagation into the channel. As the breakwater helps to stop the spit from eroding and therefore affords protection to The Point car park and surrounding land, it could be assumed that both the breakwater and spit contributes to flood and coastal erosion risk management and should be considered in the future management regime for the BMP frontage.

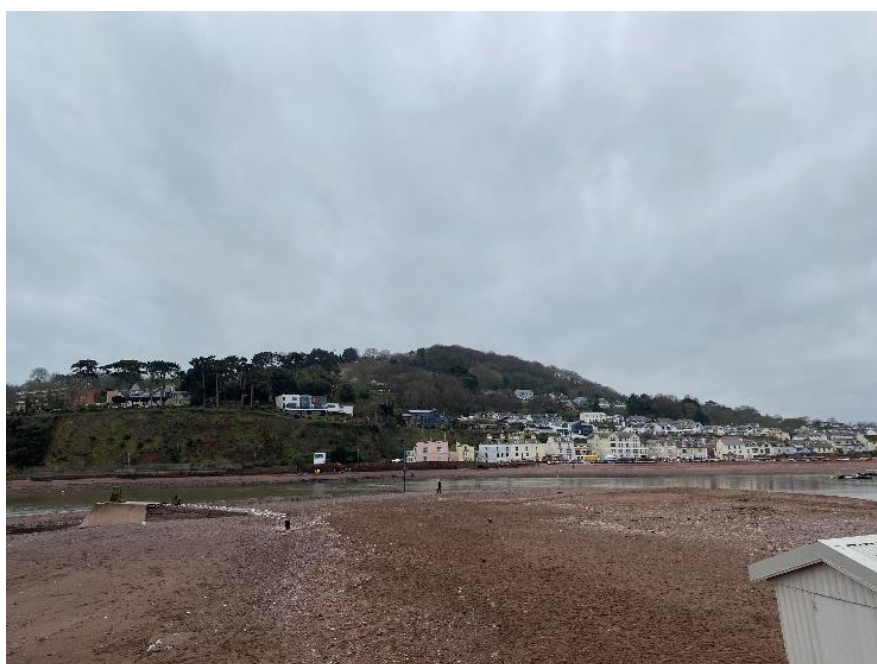

Figure 2-1 Image showing location of The Point breakwater.

Table 2.1 Teignmouth BMP longlist – measures shortlisted for further appraisal

Location	Measure Number	FCERM Category	FCERM Generic Option	FCERM Option Description (SoS, DL, SoP)	Take Forward to Shortlist Appraisal (Y/N)	Summary of Rationale for Discounting from Longlist / Taking Forward to Shortlist	In Combination Options to Consider
Teignmouth Open Coast	TOC-3	SoS: sustain for 100 years DL: 100 years SoP: gradually decreasing	Existing seawall (masonry wall - south, concrete recurve wall, concrete wall, masonry clad concrete wall - north).	Repair and maintain the asset, and replace it as it reaches the end of its RL to the same standard of service (i.e. same physical dimensions).	Y	Holds shoreline in position. Protects from flooding and erosion. As sea levels rise, the risk of increased overtopping and potential undermining will remain. Disadvantages could be mitigated against by increasing the height of the seawall in the future. Risk of undermining could be mitigated against by considering in combination with toe protection (via a structure or beach)	Toe protection (structures/beach)
Teignmouth Open Coast	TOC-4	SoS: improve for 100 years DL: 100 years SoP: sustain current for 100 years	Existing seawall (masonry wall - south, concrete recurve wall, concrete wall, masonry clad concrete wall - north).	Raise the height of the seawall to achieve current levels of overtopping in year 100. If existing wall not suitable for raising consider set-back wall or construct new wall.	Y	Holds shoreline in position Protects from flooding and erosion As sea levels rise, the risk of overtopping will continue and potential undermining will remain. Disadvantages could be mitigated against by increasing the height of the seawall in the future. Risk of undermining could be mitigated against by considering in combination with toe protection (via a structure or beach)	Toe protection (structures/beach)
Teignmouth Open Coast	TOC-5	SoS: improve for 100 years DL: 100 years SoP: improve for 100 years	Existing seawall (masonry wall - south, concrete recurve wall, concrete wall, masonry clad concrete wall - north).	Raise the height of the seawall to achieve reduced levels of overtopping in year 100. If existing wall not suitable for raising consider set-back wall or construct new wall.	Y	Holds shoreline in position Protects from flooding and erosion Provides a robust solution No change to existing coastal processes No detrimental impact on the environment	Toe protection (structures/beach)
Teignmouth Open Coast	TOC-8	SoS: improve for 100 years DL: 100 years SoP: improve for 100 years	Beach recharge - import new material	Utilise borrow site material to raise height/width of the beach. Top up recharges as required.	Y	Increases beach levels - benefit to toe protection to seawall, reduces overtopping, and provides amenity Works with coastal processes	Sustain/Improve seawall
Teignmouth Open Coast	TOC-11	SoS: sustain for 100 years DL: 100 years	Existing sheet piles.	Repair and maintain the existing toe piles as they reach the end of their RL, replace sheet piles as they fail due to corrosion with same standard of service (i.e. same length / thickness).	Y	Provides protection to the seawall, enhancing its RL Cost effective No change to existing coastal processes No detrimental impact on the environment	Sustain/Improve seawall Beach (recycling/recharge)
Teignmouth Open Coast	TOC-12	SoS: improve for 100 years DL: 100 years	New toe protection works along existing sheet piled toe (gabions, timber cribwork, rock armour, sheet piles)	Construct new toe protection at the bottom of the existing wall (below the bottom step) along the entire length of the Teignmouth Open Coast seawall removing reliance on beach to reduce risk from scour and undermining.	Y	Increases resilience of the seawall, protecting from undermining and reducing reliance of beach to protect the seawall toe	Sustain/Improve seawall Beach (recycling/recharge)

Location	Measure Number	FCERM Category	FCERM Generic Option	FCERM Option Description (SoS, DL, SoP)	Take Forward to Shortlist Appraisal (Y/N)	Summary of Rationale for Discounting from Longlist / Taking Forward to Shortlist	In Combination Options to Consider
Teignmouth Open Coast	TOC-13	SoS: improve for 100 years DL: 100 years	New toe protection works (gabions, timber cribwork, rock armour, sheet piles)	Construct new rock revetment along the entire length of the Teignmouth Open Coast seawall removing reliance on beach to prevent undermining. (e.g., rock armour, concrete blocks/steps). Proposed structure extents designed to provide increased resilience against undermining in year 100.	Y	Increases resilience of the seawall, protecting from undermining and reducing reliance of beach to protect the seawall toe	Sustain/Improve seawall Beach (recycling/recharge)
Teignmouth Open Coast	TOC-14	SoS: not maintained, fails end of RL DL: reduced SoP: gradually decreasing	Existing 14no. Groynes (1no. SWW outfall pipe, 13no. Timber groynes).	No maintenance. Allow groyne to fail at end of RL and remove structure for safety.	Y	Groynes help to stabilise the beach, which in turns provides protection to the seawall toe. Seawall protection would need to be provided via an alternative means.	n/a
Teignmouth Open Coast	TOC-15	SoS: <u>maintain</u> to end of RL DL: as present SoP: gradually decreasing	Existing 14no. Groynes (1no. SWW outfall pipe, 13no. Timber groynes).	Repair and maintain asset to extend its RL but do not replace. Remove the structure after it fails for safety.	Y	Groynes help to stabilise the beach, which in turns provides protection to the seawall toe. Seawall protection would need to be provided via an alternative means.	n/a
Teignmouth Open Coast	TOC-17	SoS: improve for 100 years DL: 100 years	New timber groynes.	When existing groynes reach the end of their RL construct a new and improved groyne field that will retain a higher beach e.g. by adjusting groyne length/height/spacing.	Y	Helps to maintain the beach and provide toe protection to the seawall A preferred option to TOC-16 as the groynes require maintenance to the existing state	Sustain/Improve seawall Beach (recycling/recharge)
Teignmouth Open Coast	TOC-18	SoS: improve for 100 years DL: 100 years SoP: <u>improve</u> for 100 years	New <u>timber</u> groynes.	When existing groynes reach the end of their RL construct a new and improved groyne field that will provide and <u>improve SoP to year 100</u> . e.g. by adjusting groyne length/height/spacing.	Y	Helps to maintain the beach and provide toe protection to the seawall Has additional advantage as effectiveness will be sustained over time as sea levels rise	Sustain/Improve seawall Beach (recycling/recharge)
Teignmouth Open Coast	TOC-19	SoS: improve for 100 years DL: 100 years	New <u>rock</u> groynes.	When existing groynes reach the end of their RL construct new rock groynes that are <u>more effective</u> than the current arrangement of timber groynes (when new) e.g. by adjusting groyne length/height/spacing., or fishtail (or "Y-shaped") groynes.	Y	Helps to maintain the beach and provide toe protection to the seawall Has additional advantage as effectiveness will be sustained over time as sea levels rise Low maintenance costs in longer term	Sustain/Improve seawall Beach (recycling/recharge)
The Point	TP-3	SoS: sustain for 100 years DL: 100 years SoP: gradually decreasing	The Point breakwater	Repair and maintain the asset, and replace it as it reaches the end of its RL to the same standard of service (i.e. same physical dimensions).	Y	Modelling does not indicate a significant reduction in wave heights on the leeward side of the spit if the breakwater is removed but it does demonstrates stabilisation of the point spit which in turn reduces erosion around the point car park area.	Preferred options for TOC & TBB
The Point	TP-4	SoS: improve for 100 years DL: 100 years SoP: <u>sustain</u> current for 100 years	The Point breakwater	<u>Upgrade</u> existing structure along same alignment so that it is as effective in year 100 as it is today (e.g. by extending length and/or raising).	Y	Modelling does not indicate a significant reduction in wave heights on the leeward side of the spit if the breakwater is removed but it does demonstrates stabilisation of the point spit	Preferred options for TOC & TBB

Location	Measure Number	FCERM Category	FCERM Generic Option	FCERM Option Description (SoS, DL, SoP)	Take Forward to Shortlist Appraisal (Y/N)	Summary of Rationale for Discounting from Longlist / Taking Forward to Shortlist	In Combination Options to Consider
						which in turn reduces erosion around the point car park area. SoP will fall over time with rising sea level.	
Teignmouth Back Beach	TBB-3	SoS: sustain for 100 years DL: 100 years SoP: gradually decreasing	Existing flood defences (Concrete flood walls, masonry flood walls, masonry property walls, masonry property walls with glazing, rendered property walls, engineered high-ground, flood gates x8, demountable flood board x1) Existing Flood Warning Direct (FWD) (EA, 2010) Existing Automated telephone flood warning service.	Repair and maintain existing assets and replace at end of RL to the same standard of service (i.e. same physical dimensions). Existing flood warning services continue.	Y	Holds shoreline in position Protects from flooding and erosion As sea levels rise, the risk of increased overtopping and potential undermining will remain. Disadvantages could be mitigated against by increasing the height of the seawall in the future. Risk of undermining could be mitigated against by considering in combination with toe protection (via a structure or beach)	n/a
Teignmouth Back Beach	TBB-4	SoS: improve for 100 years DL: 100 years SoP: <u>sustain</u> current for 100 years	Existing flood defences (Concrete flood walls, masonry flood walls, masonry property walls, masonry property walls with glazing, rendered property walls, engineered high-ground, flood gates x8, demountable flood board x1). Existing Flood Warning Direct (FWD) (EA, 2010) Existing Automated telephone flood warning service	Raise the height of existing flood defences to achieve <u>current levels of overtopping</u> in year 100. Existing flood warning services continue.	Y	Holds shoreline in position Protects from flooding and erosion As sea levels rise, the risk of overtopping will continue and potential undermining will remain. Disadvantages could be mitigated against by increasing the height of the seawall in the future. Risk of undermining could be mitigated against by considering in combination with toe protection (via a structure or beach)	n/a
Teignmouth Back Beach	TBB-6	SoS: improve for 100 years DL: 100 years SoP: <u>improve</u> for 100 years	New floodwall	Construct new floodwall of the same design along the length of the Teignmouth Back Beach with a consistent 1:200 SoP crest level. Would replace reliance on existing property walls with new continuous flood wall.	Y	Holds shoreline in position Protects from flooding and erosion A large wall may be required (height and footprint), with significant construction disturbance Very high cost	n/a
Teignmouth Back Beach	TBB-12	SoS: improve for 100 years DL: 100 years	New toe protection works (gabions, timber cribwork, concrete/masonry/rock revetment, piled toe/concrete cap)	Construct new toe protection at the bottom of the existing wall (below the bottom step) along the entire length of the Teignmouth Back Beach seawall removing reliance on beach to prevent undermining. Proposed structure extends designed to provide <u>existing resilience</u> against undermining (provided by the existing beach) in year 100.	Y	Increases resilience of the seawall, protecting from undermining and reducing reliance of beach to protect the seawall toe	Sustain/Improve seawall & flood defences

Location	Measure Number	FCERM Category	FCERM Generic Option	FCERM Option Description (SoS, DL, SoP)	Take Forward to Shortlist Appraisal (Y/N)	Summary of Rationale for Discounting from Longlist / Taking Forward to Shortlist	In Combination Options to Consider
Teignmouth Back Beach	TBB-13	SoS: improve for 100 years DL: 100 years	New toe protection works (gabions, timber cribwork, concrete/masonry/rock revetment, piled toe/concrete cap)	Construct new rock revetment along the entire length of the Teignmouth Back Beach seawall removing reliance on beach to prevent undermining. (e.g., rock armour, concrete blocks/steps). Proposed structure extents designed to provide <u>increased resilience</u> against undermining in year 100.	Y	Increases resilience of the seawall, protecting from undermining and reducing reliance of beach to protect the seawall toe With additional advantage of providing increased protection as sea levels rise	Sustain/Improve seawall & flood defences
Shaldon	S-3	SoS: sustain for 100 years DL: 100 years SoP: gradually decreasing	Existing seawall (Concrete seawall, Masonry seawall, Flood gates x5, Demountable flood boards x2)	Repair and maintain existing structures and replace at end of RL to the same standard of service (i.e. same physical dimensions).	Y	Holds shoreline in position Protects from flooding and erosion No improvement to current risk levels, and as sea levels rise, the risk of increased overtopping and potential undermining will remain and worsen. Disadvantages could be mitigated against by increasing the height of the seawall in the future Risk of undermining could be mitigated against by considering in combination with toe protection (via a structure or beach)	Toe protection (structures/beach)
Shaldon	S-4	SoS: improve for 100 years DL: 100 years SoP: <u>sustain</u> current for 100 years	Existing seawall (Concrete seawall, Masonry seawall, Flood gates x5, Demountable flood boards x2)	Raise the height of the seawall to achieve <u>current</u> levels of overtopping in year 100. If existing wall not suitable for raising, construct new wall.	Y	Holds shoreline in position Protects from flooding and erosion As sea levels rise, the risk of increased overtopping and potential undermining will remain. Disadvantages could be mitigated against by increasing the height of the seawall in the future Risk of undermining could be mitigated against by considering in combination with toe protection (via a structure or beach)	Toe protection (structures/beach)
Shaldon	S-10	SoS: improve for 100 years DL: 100 years	New toe protection works (gabions, timber cribwork, concrete/masonry/rock revetment, piled toe/concrete cap)	Construct new toe protection at the bottom of the existing wall removing reliance on beach to prevent undermining. Proposed structure extents designed to provide existing resilience against undermining (provided by the existing beach) in year 100.	Y	Increases resilience of the seawall, protecting from undermining and reducing reliance of beach to protect the seawall toe	Sustain/Improve seawall
Shaldon	S-11	SoS: improve for 100 years DL: 100 years	New toe protection works (gabions, timber cribwork, concrete/masonry/rock revetment, piled toe/concrete cap)	Construct new rock revetment removing reliance on beach to prevent undermining. (e.g., rock armour, concrete blocks/steps). Proposed structure extents designed to provide increased resilience against undermining in year 100.	Y	Increases resilience of the seawall, protecting from undermining and reducing reliance of beach to protect the seawall toe With additional advantage of providing increased protection as sea levels rise	Sustain/Improve seawall

3. Shortlist Appraisal

3.1 Shortlist appraisal approach

The purpose of the shortlist appraisal is to assess the viability of the shortlisted measures in more detail, with a view to determine a preferred option (which can consist of a combination of shortlisted measures). For the BMP, this was completed using the findings of two additional pieces of work, including a measures cost assessment and options modelling, both of which are described in more detail below.

The full shortlist appraisal table is presented in the accompanying spreadsheet in Appendix B (Teignmouth BMP_Shortlist_Appraisal_PO1).

3.1.1 Options cost assessment of the costs and benefits

A more vigorous assessment of the economic viability was required to determine the suitability and availability of the shortlisted measures. For the assessment, the costs of each shortlisted measure has been compiled.

A benefit:cost ratio (BCR) assessment for each of the shortlisted options has also been completed to use in future funding calculations. The value of benefits is based on the difference between Do Nothing and Sustain Standard of Service (SoS) provided in the Economics Baseline (see Appendix D to the BMP). The benefits of any improve option will therefore be higher and should be assessed in more detail in any future business case. The assessment of BCR has been completed for Shaldon and Teignmouth together (for the reasons outlined in Section 3.2).

Measures costs were derived from existing literature and recently constructed schemes, and damages were sourced from the information presented in the Economics Baseline.

The full option cost assessment is presented in the accompanying spreadsheet in Appendix C (Teignmouth BMP Shortlist Costing Rev P01). It should be noted that the do minimum options have not been costed for the purpose of the BMP, however, this would be required when preparing a formal business case.

3.1.2 Shortlist options modelling

Options modelling for a selection of groyne options to better understand their effect on coastal processes and shoreline change was carried out. A summary of the options modelling is provided in this section and presented in full in the Coastal Processes Baseline Report (refer to Appendix A to the BMP). A synopsis and interpretation of the findings is presented in 0.

Two shortlisted options were modelled:

1. **Shortlist option (TOC-15) – Reinstatement of the timber groyne field along Teignmouth open coast (*'with groynes scenario'*)** assumed to be similar to the 'as-built' design, including original location and dimension (described Section 2.2.1 of the Defences Baseline, Appendix B to the BMP). The groynes were represented in the model as fully non-permeable structures and were considered to be tied into the seawall (unlike at present where they are not-tied and are outflanked and beach material is washed around the top of the groyne).
 - a. Rationale: to determine whether reusing these groynes could effectively mitigate ongoing beach lowering.
2. **Shortlist option (to be implemented as in-combination option) – Reintroduction of timber groynes with a relocated dredged material disposal site (*'with groynes + relocated dredged material disposal site scenario'*)**. This scenario also involved reinstating the timber groynes with the same locations and dimensions as Shortlist Measure TOC-15. This option also includes relocating the sediment disposal site

from the current disposal site at Sprey Point to the nearshore area south of the Pier, near Teignmouth Beach for material dredged from the estuary channel.

- a. Rationale: given the prevailing northward sediment transport patterns, the intention was to assess if the additional sediment from this offshore disposal site could be effectively transported toward the beach, thereby counteracting beach lowering.

For each option a baseline scenario without groynes was also run for comparison.

3.1.3 Option modelling results

Following the results of the modelling assessments, the following impacts on sediment retention were noted:

Table 3.1 Calculated beach volume loss along the Teignmouth open coast (14 May 2018 to 12 February 2020).

Scenarios	Erosion Volume (m ³)
Baseline (2018 to 2020)	14,258
Without groynes scenario	16,960
With groynes scenario + relocated dredged material disposal site	16,822

Despite some localised issues, the overarching conclusion is that the groynes benefit beach control and therefore offer protection to the seawall and are therefore an option to be considered/ included in shortlist.

3.2 Shortlist of measures & options

The longlist of measures was rationalised from a total of 52 to 23 within the shortlist appraisal, with the breakdown shown for each BMP location in Table 3.2.

Table 3.2 Longlist and shortlist measure numbers

BMP frontage location	Longlist options	Short-list options
Teignmouth Open Coast	19	12
The Point	9	2
Teignmouth Back Beach	13	5
Shaldon	11	4
TOTAL	52	23

To be able to assess the short-listed options economically, it has been assumed that Shaldon and Teignmouth are linked by the coastal dynamics and hydrodynamics of the mouth of Teignmouth estuary and to ensure affordability for a scheme it is advised that the area is considered as one unit. Therefore, those with a shared benefit area in Teignmouth have been grouped with the Shaldon benefit area and the preferred grouped options assessed on this basis (*see also note below).

The measures have been grouped into four shortlisted options to deliver a range of options, including: Sustain and Improve 1 – 3, where Improve 1 and 2 are improve SoS and Sustain SoP using alternative measures and Improve 3 is improve both SoS and SoP, See Table 3.3 to Table 3.6. Details of the costs, benefits and resultant benefit:cost ratio of each short-listed option are provided in these tables, as well as the shortlist appraisal table presented in Appendix B.

*Appreciating that this may be a nuanced approach and as requested by the Client, separate costs, benefits and the resultant benefit:cost ratio for Shaldon only are also provided for each option.

The nationally preferred option would be the option with the highest incremental benefit cost ratio, or if there are compelling local reasons, any option with a BCR > 1 may be chosen if it can be fully funded. Given all four shortlisted options had a BCR > 1, discussions were held with the client to discuss the advantages and disadvantages of each and determine which would be the preferred local option. From that, a preferred option was selected. The rationale for option selection for the purposes of progressing the BMP is presented in Table 3.7.

Further assessment of benefits for improvement in SoP would be required to confirm BCRs and defined incremental BCRs to confirm a preferred option.

As noted in Section 2.1.4.1, all short-listed options will include the beneficial use of dredged (and eroded cliff material where possible). It has not been included as a specific measure within the options appraisal as it cannot be relied on as a regular source of material to mitigate beach lowering, however, noting the findings and recommendation made in the Coastal Processes Baseline to place the dredge material nearshore, any future management of the BMP frontage should include for this.

Table 3.3 Teignmouth BMP shortlist options – Option 1 – Sustain SOS – falling SOP over time.

Location	Measure Number	FCERM Category	Existing Structures / Proposed Structures	Measure Detail / Implementation	Proposed Time of Works	PV Cost (£k)	PV Benefits (£k)	BCR	Take Forward as Preferred Option (Y/N)
Teignmouth Open Coast	TOC-3	Flood protection	Existing seawall (masonry wall - south, concrete recurve wall, concrete wall, masonry clad concrete wall - north).	Repair and maintain the asset, and replace it as it reaches the end of its RL to the same standard of service (i.e. same physical dimensions).	2043	9,375			No
Teignmouth Open Coast	TOC-11	Erosion control structure	Existing sheet piles.	Repair and maintain the existing toe piles as they reach the end of their RL, replace sheet piles as they fail due to corrosion with same standard of service (i.e. same length / thickness).	2043	5,743			
Teignmouth Open Coast	TOC-17	Beach control structure	New timber groynes.	Construct a new and improved groyne field that will retain a higher beach e.g. by adjusting groyne length/height/spacing.	2028	6,575			
The Point	TP-3	Flood protection	The Point breakwater	Repair and maintain the asset, and replace it as it reaches the end of its RL to the same standard of service (i.e. same physical dimensions).	2043	771			
Teignmouth Back Beach	TBB-3	Flood protection	Existing flood defences (Concrete flood walls, masonry flood walls, masonry property walls, masonry property walls with glazing, rendered property walls, engineered high-ground, flood gates x8, demountable flood board x1) Existing Flood Warning Direct (FWD) (EA, 2010) Existing Automated telephone flood warning service.	Repair and maintain existing assets and replace at end of RL to the same standard of service (i.e. same physical dimensions). Existing flood warning services continue.	Flood gates 2045 Demountable barrier 2083 High walls 2080 Low walls 2103	472			
Shaldon	S-3	Flood protection	Existing seawall (Concrete seawall, Masonry seawall, Flood gates x5, Demountable flood boards x2)	Repair and maintain existing structures and replace at end of RL to the same standard of service (i.e. same physical dimensions).	Seawall 2082 Flood gates 2045 Demountable barrier 2073	1,306			
					TOTAL BMP FRONTAGE	24,243	73,300	3.02	
					Teignmouth Open Coast, The Point and Back Beach only	22,937	72,800	3.17	
					Shaldon only	1,306	500	0.38	

Table 3.4 Teignmouth BMP shortlist options – Option 2 - Improve 1 - improve SOS, sustain SOP.

Location	Measure Number	FCERM Category	Existing Structures / Proposed Structures	Measure Detail / Implementation	Proposed Time of Works	PV Cost (£k)	PV Benefits (£k)	BCR	Take Forward as Preferred Option (Y/N)
Teignmouth Open Coast	TOC-3	Flood protection	Existing seawall (masonry wall - south, concrete recurve wall, concrete wall, masonry clad concrete wall - north).	Repair and maintain the asset, and replace it as it reaches the end of its RL to the same standard of service (i.e. same physical dimensions).	2043	9,375			No
Teignmouth Open Coast	TOC-8	Flood protection	Beach recharge - import new material	Utilise borrow site material to raise height/width of the beach. Top up recharges as required over the design life.	2028	12,042			
Teignmouth Open Coast	TOC-11	Erosion control structure	Existing sheet piles.	Repair and maintain the existing toe piles as they reach the end of their RL, replace sheet piles as they fail due to corrosion with same standard of service (i.e. same length / thickness).	2043	5,743			
Teignmouth Open Coast	TOC-17	Beach control structure	New timber groynes.	Construct a new and improved groyne field that will retain a higher beach e.g. by adjusting groyne length/height/spacing.	2028	6,575			
The Point	TP-3	Flood protection	The Point breakwater	Repair and maintain the asset, and replace it as it reaches the end of its RL to the same standard of service (i.e. same physical dimensions).	2043	771			
Teignmouth Back Beach	TBB-3	Flood protection	Existing flood defences (Concrete flood walls, masonry flood walls, masonry property walls, masonry property walls with glazing, rendered property walls, engineered high-ground, flood gates x8, demountable flood board x1) Existing Flood Warning Direct (FWD) (EA, 2010) Existing Automated telephone flood warning service.	Repair and maintain existing assets and replace at end of RL to the same standard of service (i.e. same physical dimensions). Existing flood warning services continue.	Flood gates 2045 Demountable barrier 2083 High walls 2080 Low walls 2103	472			
Shaldon	S-3	Flood protection	Existing seawall (Concrete seawall, Masonry seawall, Flood gates x5, Demountable flood boards x2)	Repair and maintain existing structures and replace at end of RL to the same standard of service (i.e. same physical dimensions).	Seawall 2082 Flood gates 2045 Demountable barrier 2073	1,306			
					TOTAL BMP FRONTAGE	36,285	73,300	2.02	
					Teignmouth Open Coast, The Point and Back Beach only	34,979	72,800	2.08	
					Shaldon only	1,306	500	0.38	

Table 3.5 Teignmouth BMP shortlist options – Option 3 - Improve 2 - improve SOS, sustain SOP.

Location	Measure Number	FCERM Category	Existing Structures / Proposed Structures	Measure Detail / Implementation	Proposed Time of Works	PV Cost (£k)	PV Benefits (£k)	BCR	Take Forward as Preferred Option (Y/N)
Teignmouth Open Coast	TOC-4	Flood protection	Existing seawall (masonry wall - south, concrete recurve wall, concrete wall, masonry clad concrete wall - north).	Raise the height of the seawall to achieve current levels of overtopping in year 100. If existing wall not suitable for raising consider set-back wall or construct new wall.	2028	18,042			Yes
Teignmouth Open Coast	TOC-11	Erosion control structure	Existing sheet piles.	Repair and maintain the existing toe piles as they reach the end of their RL, replace sheet piles as they fail due to corrosion with same standard of service (i.e. same length / thickness).	2043	5,743			
Teignmouth Open Coast	TOC-12	Erosion control structure	New toe protection works along existing sheet piled toe (gabions, timber cribwork, rock armour, sheet piles)	Construct new toe protection at the bottom of the existing wall (below the bottom step) along the entire length of the Teignmouth Open Coast seawall removing reliance on beach to reduce risk from scour and undermining.	2028	3,678			
Teignmouth Open Coast	TOC-17	Beach control structure	New timber groynes.	Construct a new and improved groyne field that will retain a higher beach e.g. by adjusting groyne length/height/spacing.	2028	6,575			
The Point	TP-4	Flood protection	The Point breakwater	<u>Upgrade</u> existing structure along same alignment so that it is as effective in year 100 as it is today (e.g. by extending length and/or raising).	2028	1,355			
Teignmouth Back Beach	TBB-4	Flood protection	Existing flood defences (Concrete flood walls, masonry flood walls, masonry property walls, masonry property walls with glazing, rendered property walls, engineered high-ground, flood gates x8, demountable flood board x1). Existing Flood Warning Direct (FWD) (EA, 2010) Existing Automated telephone flood warning service	Raise the height of existing flood defences to achieve <u>current levels of overtopping</u> in year 100. Existing flood warning services continue.	Flood gates 2028 Demountable barrier 2028 High walls 2080 Low walls 2028	2,635			
Teignmouth Back Beach	TBB-12	Erosion control structure	New toe protection works (gabions, timber cribwork, concrete/masonry/rock revetment, piled toe/concrete cap)	Construct new toe protection at the bottom of the existing wall (below the bottom step) along the entire length of the Teignmouth Back Beach seawall removing reliance on beach to prevent undermining. Proposed structure extents designed to provide <u>existing resilience</u> against undermining (provided by the existing beach) in year 100.	2028	962			
Shaldon	S-4	Flood protection	Existing seawall (Concrete seawall, Masonry seawall, Flood gates x5, Demountable flood boards x2)	Raise the height of the seawall to achieve <u>current</u> levels of overtopping in year 100. If existing wall not suitable for raising, construct new wall.	Seawall (higher wall) 2082, Seawall (lower wall) 2028, Flood gates 2028, Demountable barrier 2028	3,757			
Shaldon	S-10	Erosion control structure	New toe protection works (gabions, timber cribwork, concrete/masonry/rock revetment, piled toe/concrete cap)	Construct new toe protection at the bottom of the existing wall removing reliance on beach to prevent undermining. Proposed structure extents designed to provide <u>existing resilience</u> against undermining (provided by the existing beach) in year 100.	2028	2,263			
					TOTAL BMP FRONTAGE	45,010	73,300	1.63	
					Teignmouth Open Coast, The Point and Back Beach only	42,757	72,800	1.70	
					Shaldon only	2,263	500	0.22	

Table 3.6 Teignmouth BMP shortlist options – Option 4 - Improve 3 - improve SOS, improve SOP .

Location	Measure Number	FCERM Category	Existing Structures / Proposed Structures	Measure Detail / Implementation	Proposed Time of Works	PV Cost (£k)	PV Benefits (£k)	BCR	Take Forward as Preferred Option (Y/N)
Teignmouth Open Coast	TOC-5	Flood protection	Existing seawall (masonry wall - south, concrete recurve wall, concrete wall, masonry clad concrete wall - north).	Raise the height of the seawall to achieve reduced levels of overtopping in year 100. If existing wall not suitable for raising consider set-back wall or construct new wall.	2028	18,321			No
Teignmouth Open Coast	TOC-11	Erosion control structure	Existing sheet piles.	Repair and maintain the existing toe piles as they reach the end of their RL, replace sheet piles as they fail due to corrosion with same standard of service (i.e. same length / thickness).	2043	5,743			
Teignmouth Open Coast	TOC-13	Erosion control structure	New toe protection works (gabions, timber cribwork, rock armour, sheet piles)	Construct new rock revetment along the entire length of the Teignmouth Open Coast seawall removing reliance on beach to prevent undermining. (e.g., rock armour, concrete blocks/steps). Proposed structure extents designed to provide increased resilience against undermining in year 100.	2028	4,809			
Teignmouth Open Coast	TOC-19	Beach control structure	New <u>rock</u> groynes.	Construct new rock groynes that are <u>more effective</u> than the current arrangement of timber groynes (when new) e.g. by adjusting groyne length/height/spacing., or fishtail (or "Y-shaped") groynes.	2028	6,601			
The Point	TP-4	Flood protection	The Point breakwater	<u>Upgrade</u> existing structure along same alignment so that it is as effective in year 100 as it is today (e.g. by extending length and/or raising).	2028	1,355			
Teignmouth Back Beach	TBB-6	Flood protection	New floodwall	Construct new floodwall of the same design along the length of the Teignmouth Back Beach with a consistent 1:200 SoP crest level. Would replace reliance on existing property walls with new continuous flood wall.	Flood gates 2028 Demountable barrier 2028 New floodwall 2028	5,549			
Teignmouth Back Beach	TBB-13	Erosion control structure	New toe protection works (gabions, timber cribwork, concrete/masonry/rock revetment, piled toe/concrete cap)	Construct new rock revetment along the entire length of the Teignmouth Back Beach seawall removing reliance on beach to prevent undermining. (e.g., rock armour, concrete blocks/steps). Proposed structure extents designed to provide <u>increased resilience</u> against undermining in year 100.	2028	1m273			
Shaldon	S-4	Flood protection	Existing seawall (Concrete seawall, Masonry seawall, Flood gates x5, Demountable flood boards x2)	Raise the height of the seawall to achieve <u>current</u> levels of overtopping in year 100. If existing wall not suitable for raising, construct new wall.	Seawall (higher wall) 2082 Seawall (lower wall) 2028 Flood gates 2028 Demountable barrier 2028	3,757			
Shaldon	S-11	Erosion control structure	New toe protection works (gabions, timber cribwork, concrete/masonry/rock revetment, piled toe/concrete cap)	Construct new rock revetment removing reliance on beach to prevent undermining. (e.g., rock armour, concrete blocks/steps). Proposed structure extents designed to provide increased resilience against undermining in year 100.	2028	2,970			
					TOTAL BMP FRONTAGE	50,372	73,300	1.45	
					Teignmouth Open Coast, The Point and Back Beach only	47,409	72,300	1.54	
					Shaldon only	2,970	500	0.17	

Table 3.7 Preferred option selection rationale

Option	Rationale
Option 1 – Sustain SOS falling SOP over time	<p>Discounted.</p> <p>Teignmouth Open Coast – Without new toe protection measures or beach recharge, there is a high risk that beach levels continue to fall resulting in the seawall between The Point and the Pier not being protected from erosion. This could lead to failure of the seawall and thereby not providing a continuous line of defence along the Teignmouth open coast.</p> <p>The Point / Teignmouth Back Beach / Shaldon – Although repairing and maintaining the structures is considered an acceptable option, this option does not provide for any futureproofing of the breakwater and existing schemes as sea levels rise and wave climate potentially change.</p>
Option 2 - Improve 1 - improve SOS, sustain SOP	<p>Discounted.</p> <p>Seawall toe protection would be provided by the beach, which would rely on combined measures of groynes and beach renourishment. Renourishment is discounted on grounds of sustainability (no guarantee that renourished material would stay in place with groynes and therefore regular top-up would potentially be required and there is no nearby borrow site ((i) Dawlish Warren SAC, which is not suitable for environmental reasons and already experiencing issues; (ii) the Isle of Wight, where the material is not of suitable sediment grading for Teignmouth, and (iii) securing a new one, which would be very expensive and would then mean that renourishment would be very costly).</p> <p>The Point / Teignmouth Back Beach / Shaldon – Although repairing and maintaining the structures is considered an acceptable option, this option does not provide for any futureproofing of the breakwater and existing schemes as sea levels rise and wave climate potentially change.</p>
Option 3 - Improve 2 - improve SOS, sustain SOP	<p>Selected as the preferred option.</p> <p>This option provides sufficient protection for the Teignmouth Open Coast frontage and includes for a seawall. It provides improved SoS, and sustains SoP. However SoP is not improved, sufficient protection would be provided in the timescales over which current funding is most likely to be secured (and could be explored in the future).</p> <p>With regard to the groynes, as recommended by the BMP, work should be completed to explore different groynes dimensions, and if viable, using a mixture of construction methods, such as timber and rock. The Teignmouth remedial works project and forthcoming OBC could be used as a conduit for this investigation.</p> <p>This option includes for futureproofing of the breakwater as sea levels rise and wave climate potentially change.</p> <p>It is accepted that recent schemes at Back Beach and Shaldon provide sufficient protection for short-medium term and are designed to be upgraded/topped-up in the future. Given this, the option lends itself to a phased approach, where Teignmouth could be prioritised and defences at Back Beach and Shaldon addressed later. The task would then be for TDC/EA to seek funding to implement this preferred option, starting with EA progressing Teignmouth open coast via the remedial works project and TDC progressing Shadon and Back Beach via the capital works programme.</p> <p>As with all short-listed options considered, the preferred option also includes consideration of beneficial use of dredge material and a change to the current dredge disposal site to one that works better with the coastal processes as we now understand them to operate (following</p>

Option	Rationale
	new work completed for the current BMP Coastal Processes Baseline), and this would by default be included within the future management regime. The recommended location for disposal would be the nearshore, adjacent to the Pier, within either groyne bay immediately to the north or south, to allow sufficient time to pass before it could be transported back toward and into the estuary channel.
Option 4 – Improve 3 – improve SOS, improve SOP	Discounted. Teignmouth Open Coast – This option is the most expensive, due to the inclusion of a new floodwall at Teignmouth back beach to improve the SOS. The measure for groynes includes construction solely from rock compared to option 3 where timber groynes are included. Further development of these options should review the viability of construction from both rock and timber. This supports Option 3 where the measure includes for timber groynes. Although the measures for the Point and Teignmouth Back Beach / Shaldon includes for futureproofing and could be implemented as outlined for Option 3, when considered alongside the measure for Teignmouth Open Coast, the option all-together is very expensive and considered less likely to obtain funding.

3.3 Teignmouth Remedial Works Strategic Outline Business Case

For completeness, a comparison of the shortlist options identified by the Teignmouth Remedial Works Strategic Outline Business Case (SOC) and the BMP options appraisal process is shown in Table 3.8. Although the SOC Do Something – 2 option is shortlisted by the BMP, it only includes one measure, which is to stabilise the wall, whereas Do Something – 4 includes for all measures identified by the BMP shortlisted options.

Table 3.8 Shortlisted options for the BMP and Teignmouth Remedial Works Strategic Outline Business Case.

Option	Shortlist decision	Technical risks	Opportunities & innovation	BMP Shortlisted Options
Do Nothing	Must be shortlisted	Maintenance of fencing, increased flood risk and frequency to community, loss of promenade (erosion of utilities and businesses).	-	None
Do Minimum Patch repair of failed seawall sections	Must be shortlisted	Reactive repair would lead to regular damages and overall high cost. Would result in inconsistent structure at the end of appraisal period.	-	None
Do Something – 2 Substantial wall stabilisation only	Sustains standard of service	Existing rates of erosion will remain, which will increase with coastal squeeze. Difficult to construct due to deep bedrock, risk of damaging nearby structures.	Working with TDC for public realm enhancements.	1,2,3,4
Do something – 3	Sustains standard of service	Significant increase in beach control structures, which may still not counteract ongoing beach erosion	Working with TDC for public realm & beach	None

Options Appraisal Report

Option	Shortlist decision	Technical risks	Opportunities & innovation	BMP Shortlisted Options
Substantial beach management + no wall stabilisation		trend. Further nourishment may be required to design life.	access enhancements.	
Do something – 4 Combination solution	Sustains standard of service	As per Do Something 2 & 3. To be explored in technical appraisal of options.	Working with TDC for public realm & beach access enhancements.	1,2,3,4

4. Preferred Option Selection

4.1 Preferred Option

The preferred option selected for future management of the BMP frontage is: **Option 3, Improve 2 - improve SOS, sustain SOP**. Full details of the option, proposed timing of works, present value costs and benefits and benefit cost ratio is presented Table 3.5.

This option assumes the wall is raised in year 2028. Further development of this option could consider, inclusion of a setback wall to provide the improved SOP with repairs to the existing included in 2028. The construction of the setback wall may not need to be installed in 2028 but may be constructed at a later date. Further analysis could be undertaken to inform when overtopping is expected to reach unacceptable levels and therefore when the wall raising would be needed / what the height the set-back wall could be. This is a recommendation for the next stage of option development.

Alongside this, it is recommended to beneficially use the material dredged from the estuary channel and the eroding cliffs landward of the railway and wherever possible are undertaken with immediate effect. This activity has not been included as a specific measure within the options appraisal as it cannot be relied on as a regular source of material to mitigate beach lowering, however, noting the findings and recommendation made in the Coastal Processes Baseline to change the current dredge disposal site to one that works better with the coastal processes as they are now understood to operate. The recommended location for disposal would be the nearshore, adjacent to the Pier, within either groyne bay immediately to the north or south, to allow sufficient time to pass before it could be transported back toward and into the estuary channel.

Ahead of implementing the preferred option, it is recommended that further work is undertaken in the immediate future to:

- Determine if the existing seawall along the open coast is suitable for raising; and
- Undertake work to explore different groynes dimensions, but if suitable, a mix of timber and rock. The Teignmouth remedial works project and forthcoming OBC could be used as a conduit for this investigation.
- Then work to seek funding to implement the preferred option.

5. References

Binnies, 2024. Teignmouth Coastal Defences Engineering Assessment. Report prepared for the Environment Agency, October 2024.

Environment Agency, 2025. Strategic outline Business Base. Teignmouth Remedial Works.

Environment Agency, 2024. Flood and coastal erosion risk management appraisal. Technical guidance. Downloaded 21st August 2025 from <https://www.gov.uk/government/publications/fcerm-appraisal-technical-guidance>.

Environment Agency, 2023a. Teignmouth Sea Defence Scheme Remedial Works Reporting.

Environment Agency, 2023b. Guidance. Develop an FCERM project business case. <https://www.gov.uk/guidance/develop-an-fcerm-project-business-case>. Published 1 September 2021; Last updated 18 August 2023.

Environment Agency, 2022. South West river basin district river basin management plan: updated 2022. = <https://www.gov.uk/guidance/south-west-river-basin-district-river-basin-management-plan-updated-2022>. Published 21 October 2022; Last updated 22 December 2022.

Halcrow, 2011. South Devon and Dorset Shoreline Management Plan. Prepared by Halcrow for the South Devon and Dorset Coastal Authorities Group (SDADCAG).

Jacobs 2025. Teignmouth and Shaldon Beach Management Plan. Report prepared by Jacobs for Teignbridge District Council.

Appendices



Appendix A Longlist Appraisal



Appendix B Shortlist Appraisal



Appendix C Shortlist Cost Assessment



Appendix D Model findings synopsis



Model findings synopsis

This appendix provides a summary and interpretation of the key findings presented in Appendix C of the BMP, including the new model studies completed for the BMP, and used to inform the measures/options appraisal.

D.1 Baseline model conditions

The model results used to develop the Coastal Processes Baseline show that the flow conditions near the coast is driven both by the effect of tides and breaking waves.

- For waves from East, the alongshore flow conditions is southwards, except near the estuary mouth where flow is northwards at peak ebb.
- For waves from South, the alongshore flow is northwards, except near the estuary mouth where flow is southwards at high tide and peak flood.
- For tides only, the flow condition is more complex, but weaker near the coast.

D.2 The Point breakwater modelling

During the development of the BMP, Teignmouth District Council, the Environment Agency and the BMP Steering Group expressed an interest to better understand the role of The Point breakwater in terms of flood and coastal erosion risk management. To support this, a stand-alone XBeach modelling study of The Point breakwater was undertaken and is included in Appendix E of the Coastal Processes Baseline Report (Appendix A to the BMP).

Modelling was completed for four single event scenarios (all of which exclude sea level rise and do not consider potential condition changes to the breakwater); southerly and easterly storms, Storm Ciarán and an extreme storm event (1:100 year event), each with and without the point breakwater in place. The modelling shows:

- The effect of the point breakwater varies spatially and is dependent on storm direction;
 - Wave heights:
 - When the with and without breakwater scenarios are compared, the difference in wave height on the estuary side of the spit is minimal suggesting that during storms, the breakwater has little influence on wave heights across The Point.
- Beach elevation:
 - During southerly and easterly storms and Storm Ciarán, both with and without the breakwater, material is drawn down:
 - Landward side of breakwater – from the upper beach
 - Seaward side of breakwater – from the top of spit/upper beach to the lower beach/distal end of the spit.
 - During extreme easterly storms, both with and without the breakwater, material is eroded from:
 - Landward side of breakwater – the whole beach
 - Seaward side of breakwater – the top of spit/upper beach to the lower back of/distal end of the spit (roll back)
 - Difference plots show how the breakwater influences these patterns of beach elevation change, during different storm events. Without the breakwater in place:

- Easterlies – beach levels reduce immediately adjacent to the breakwater and increase around the distal end of the spit.
 - Southerlies – beach levels increase seaward of the breakwater, but reduce landward of it, and only some beach level increase toward the distal end of the spit.
 - Storm Ciaran – results in more complex patterns of differential erosion and accretion, with beach level reduction around the distal end of the breakwater and immediately landward of it, and some beach elevation increase around the distal end.
 - Extreme easterly event – results in landward movement (roll back) of the spit, with lowering and widening of the spit.
- Water levels – the with and without breakwater scenarios showed very little difference in water levels within the estuary (within cm's of each other).

There are limitations that accompany the modelling results whereby sustained high energy winter conditions or consecutive winter storms and the inclusion of sea level rise would likely (i) amplify the erosion extent and depth significantly beyond what is shown in these single-event simulations; and (ii) introduce complex morphological feedback mechanisms; and (iii) changes to the structural integrity of the breakwater could change the response of the spit during storms.

Conclusion: The breakwater itself has little impact on water levels and waves height within the estuary. However, it does have an influence on beach elevation during storms, by reducing erosion immediately adjacent to the breakwater, and the accretion of the Point (where eroded beach material could be assumed to be redistributed to) and rollback of the spit into the estuary. The presence of the spit will also act to constrain and maintain the narrow entrance channel at the mouth of the Teign Estuary, thereby reducing wave propagation into the channel. As the breakwater helps to stop the spit from eroding and there affords protection to The Point car park and surrounding land, it could be assumed that both the breakwater and spit contributes to flood and coastal erosion risk management and should be considered in the future management regime for the BMP frontage.

D.3 Shortlist options modelling

Options modelling for a selection of groyne options to better understand their effect on coastal processes and shoreline change was carried out. A summary of the options modelling is provided in this section and presented in full in the Coastal Processes Baseline Report (refer to Appendix A to the BMP).

Two shortlisted options were modelled:

1. **Shortlist option (TOC-15) – Reinstatement of the timber groyne field along Teignmouth open coast ('with groynes scenario')** assumed to be similar to the 'as-built' design, including original location and dimension (described Section 2.2.1 of the Defences Baseline, Appendix B to the BMP). The groynes were represented in the model as fully non-permeable structures and were considered to be tied into the seawall (unlike at present where they are not-tied and are outflanked and beach material is washed around the top of the groyne).
 - a. Rationale: to determine whether reusing these groynes could effectively mitigate ongoing beach lowering.
2. **Shortlist option (to be implemented as in-combination option) – Reintroduction of timber groynes with a relocated dredged material disposal site ('with groynes + relocated dredged material disposal site scenario')**. This scenario also involved reinstating the timber groynes with the same locations and dimensions as Shortlist Options TOC-15, but relocating the sediment disposal site from the current disposal site at Sprey Point to the nearshore area south of the Pier, near Teignmouth Beach.

- a. Rationale: given the prevailing northward sediment transport patterns, the intention was to assess if the additional sediment from this offshore disposal site could be effectively transported toward the beach, thereby counteracting beach lowering.

For each option a baseline scenario without groynes was also run for comparison.

D.3.1 Option modelling results

Using a combination of the modelling write-up and Jacob's in-house modelling expertise, a summary of how hydrodynamic and coastal processes along the Teignmouth open coast could be affected under different coastal management option is provided in the following sections.

D.3.2 With groynes scenario

- The reinstated timber groynes reduce alongshore sediment transport.
- The model results show that the groynes also modify the flow conditions near high tide, as evidenced by the presence of circulation cells along the groyne field (or circulatory flows) within the groyne bays.
- Circulatory flows enhance cross-shore currents due to the combination of flow acceleration over the groyne and cross-shore deflection of the flow towards the groyne tips and cross-shore flow deceleration towards the groyne tips at high tide.
- The model predicts an increase of sediment transported from the upper part of the beach (near the seawall) (erosion) towards the tip of the groynes (the landward end of the groynes) where deposition is seen to occur (accretion).
- Together, this suggests that the deposition towards the groyne tips is due to the cross-shore flow deceleration towards the groyne tips at high tide.
- These modelling results could be pessimistic. Since sediment transport is expected to occur within 0.5 m to 1.0 m of the seabed, it is more likely that a good fraction of the sediment transport reaching the groyne will be retained, since the top of the sloping part of the groyne is expected to be about 1 m of the seabed. We agree that some erosion may occur in the upper part of the beach, as the beach line adjusts to the flow circulations within each bay.
- The modelling assumes beach levels present day-beach levels, which are currently low. In addition to the cross-shore currents generated by the circulatory flows, a reduction in bed levels along the back of the beach would also be occur because the groynes would act to exacerbate scour at the interface of the landward tip of the groyne and the seawall as a result of wave reflection off the seawall and groynes.
- The comparatively limited beach lowering observed between shorter groynes suggests that adjusting groyne dimensions or permeability could help maintain greater alongshore transport, thus mitigating unintended erosion impacts (shown in Figure D 1).
- Analysis of beach volumes between 2018 and 2020 shows losses were in the region of 14,258m³ along the Teignmouth open coast. However, reinstating the groynes increases this volume loss to 16,960m³, i.e. negative difference of -2,702m³.

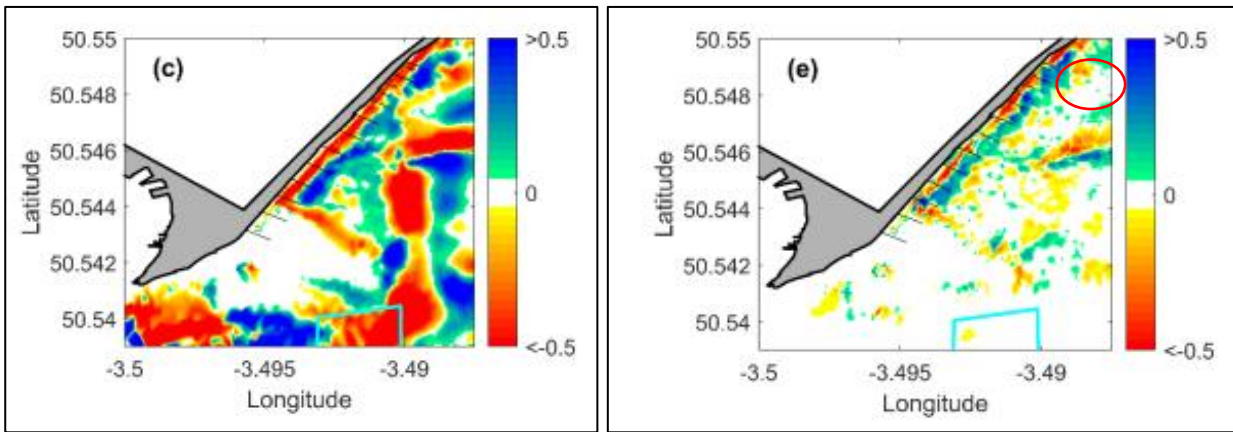

Figure D 1 Left (c) bed levels after reinstatement of groynes; and right (e) bed level change from baseline (i.e. no groynes) and after-reinstatement of groynes with area of shorter groynes shown by the red circle. Refer to Figure 9-5 of Appendix C to the BMP for the original image.

D.3.2.1 With groynes scenario + relocated dredged material disposal site

- Dredged material placed in the relocated area largely remains confined within the disposal area (shown in Figure D 2).
- There is limited redistribution towards the shoreline by wave action, where model results indicate small contribution of sediment transport from the relocated disposal area to the beach.
- Analysis of beach volumes between 2018 and 2020 (Table D 2) shows that volumes losses for the 'with groynes + recharge scenario' is less than 'with groynes' only, suggesting that recharge could mitigate against volume losses arising when groynes are reinstated.
- There could be a more suitable and optimal location for placement of the material, and the material could be used more beneficially if it were placed on the beach.

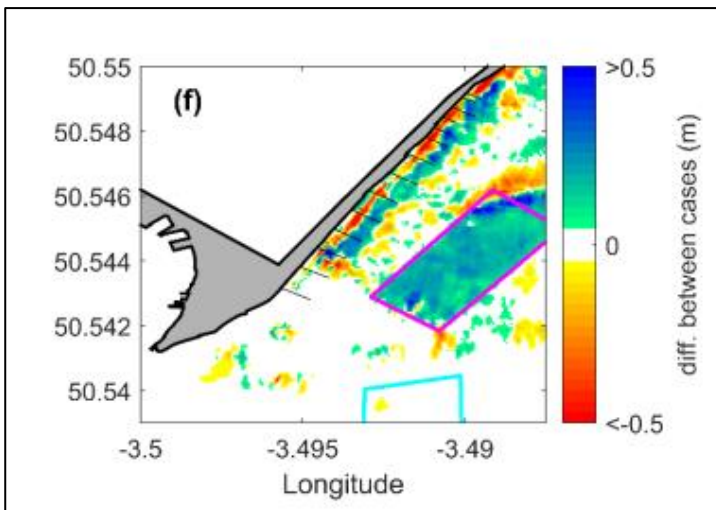

Figure D 2 Bed level change from baseline (i.e. no groynes) and after-reinstatement of groynes + relocated dredged material disposal site.

Table D 1 Calculated beach volume loss along the Teignmouth open coast (14 May 2018 to 12 February 2020).

Scenarios	Erosion Volume (m3)
Baseline (2018 to 2020)	14,258
With groynes scenario	16,960
With groynes scenario + relocated dredged material disposal site	16,822

D.3.3 Options modelling conclusions

- Reinstating the groynes along the Teignmouth open coast without any change to current beach levels could act to trap alongshore moving sediment. However, it could also result in a redistribution of beach sediment from the upper to lower beach, resulting in beach lowering and scour at the toe of the seawall, and beach elevation and accretion around the groyne tip. The net effect could be a reduction in beach loss over time. However;
 - If the aim of the groynes is to help stabilise and build-up the beach, then the option to reinstate the groynes could be supplemented with beach recharge.
 - Patterns of beach lowering at the seawall and beach accretion at the tip of the groyne may need to be mitigated against with mechanical redistribution of sediment.
 - Consideration could also be given to a shorter length of groyne, which would enable continued longshore transport of material and thereby preventing loss to downdrift beaches.
 - Increasing the spacing between groynes could also be considered. The groynes at Teignmouth are unusually close for a sand beach with spacing roughly equal to groyne length. A spacing of 2-4 times the groyne length would be more typical in order to prevent the generation of rip currents and excessive erosion between groynes.
 - Rock groynes may also be more effective as the wave diffraction they generate tends to reduce the amount of sediment erosion on their downdrift side. They also reduce wave reflections that may be an issue here. The spacing of rock groynes may be larger than timber groynes. Beaches with widely spaced rock groynes tend to generate fewer but larger rip currents than closely-spaced timber groynes. Safety for recreational use must therefore be carefully considered.
- Moving the location of the dredged disposal site further south could help to reduce beach volume loss when compared to the existing regime where material is placed further to the north. The modelled location shows some redistribution to the beach, but not all, indicating that there could be a more suitable and optimal location for placement. As also suggested by the report, the dredged material could be used beneficially to help mitigate beach lowering by being placed directly on the beach. The practicalities of this option would need to be investigated further with Teignbridge District Council, The Environment Agency and the Teignmouth Harbour Commissioner.

D.3.4 Recommendations for further modelling

It is recommended that further modelling is undertaken to build on the recommendations of the options modelling and explore further the impact that groynes of different length, height or permeability may have on coastal processes, along with a changes to the placement of dredge material. In undertaking the BMP, work was completed to scope out possible model runs, but this was not taken further forward at this stage with a view that it could be completed as part of the Teignmouth Remedial Works project. The proposed mode runs are summarised in Table D 2 Proposed model runs.

Table D 2 Proposed model runs.

Run Number	Recharge	Groyne height	Groyne spacing	Groyne length	North of pier only	Cross-sections
1	Max licensed (15,000m ³)	Reduced = 0mOD	Every second groyne (based on current spacing)	Long groynes shortened to ¾ of existing. No change to short groynes.	n/a	<10
2	Max licensed (15,000m ³)	Reduced = 0mOD	As existing	Long groynes shortened to ¾ of existing. No change to short groynes.	n/a	<10
3	Max licensed (15,000m ³)	Reduced = 0mOD	Every second groyne (based on current spacing)	Long groynes shortened to ¾ of existing. No change to short groynes.	Groynes north of pier only	<10